



**METAL-FACH**



**“HORNET” MANURE SPREADER  
N267, N267/1, N267/2**

**PARTS CATALOGUE**

EDITION I  
MARCH 2019



Information included in the catalogue is valid as of the date of its preparation. The manufacturer reserves its right to make design changes to machines, and due to this, some values or illustrations might not correspond to the actual state of the machine supplied to the user. The manufacturer reserves its right to make design changes without changing this catalogue.

## Table of Contents

Table of Contents .....	3
1. HITCH AND SUPPORT FOOT.....	6
2. HITCH AND SUPPORT FOOT.....	8
3. WHEEL CHOCKS .....	10
4. LADDER .....	12
5. FRONT PANEL, SIDE PANELS AND MESH .....	14
6. FRONT PANEL.....	16
7. STAKES AND SIDE PANELS.....	18
8. END OF THE PANEL .....	20
9. METAL SHEET EXTENSIONS.....	22
10. NET EXTENSIONS .....	24
11. MUDGUARD.....	26
12. REAR GUARD.....	28
13. FLOOR CONVEYOR .....	30
14. TENSIONER, COMPLETE.....	32
15. REAR SHAFT, COMPLETE.....	34
16. REAR SHAFT, COMPLETE.....	36
17. DRIVE UNIT .....	38
18. DRIVE UNIT .....	40
19. SINGLE-SECTION HYDRAULIC SYSTEM (WITH A DISTRIBUTOR).....	42
20. SINGLE-SECTION HYDRAULIC SYSTEM (WITH A DISTRIBUTOR) - conveyor section.....	43
21. SINGLE-SECTION HYDRAULIC SYSTEM (WITH A DISTRIBUTOR) - conveyor section.....	45

22. SINGLE-SECTION HYDRAULIC SYSTEM (WITH A DISTRIBUTOR) - conveyor section. ....	47
23. SINGLE-SECTION HYDRAULIC SYSTEM (WITH A DISTRIBUTOR) - gate valve section.....	49
24. SINGLE-SECTION HYDRAULIC SYSTEM (WITH A DISTRIBUTOR) - gate valve section.....	51
25. SINGLE-SECTION HYDRAULIC SYSTEM (WITH A DISTRIBUTOR) - control section. ....	53
26. SINGLE-SECTION HYDRAULIC SYSTEM (WITH A DISTRIBUTOR) - control section. ....	55
27. TWO-SECTION HYDRAULIC SYSTEM .....	59
28. TWO-SECTION HYDRAULIC SYSTEM - conveyor section.....	60
29. TWO-SECTION HYDRAULIC SYSTEM - conveyor section.....	62
30. TWO-SECTION HYDRAULIC SYSTEM - conveyor section.....	64
31. TWO-SECTION HYDRAULIC SYSTEM - gate valve section. ....	66
32. TWO-SECTION HYDRAULIC SYSTEM - gate valve section. ....	68
33. BRAKING SYSTEM with ALB .....	72
34. BRAKING SYSTEM with ALB .....	74
35. BRAKING SYSTEM with ALB .....	76
36. BRAKING SYSTEM (SPRING SUSPENSION) .....	79
37. BRAKING SYSTEM (SPRING SUSPENSION) .....	81
38. BRAKING SYSTEM (SPRING SUSPENSION) .....	83
39. 2-LINE PNEUMATIC BRAKING SYSTEM (TANDEM) .....	86
40. 2-LINE PNEUMATIC BRAKING SYSTEM (TANDEM) .....	88
41. 1-LINE PNEUMATIC BRAKING SYSTEM (TANDEM) .....	90
42. 1-LINE PNEUMATIC BRAKING SYSTEM (TANDEM) .....	92
43. HYDRAULIC BRAKING SYSTEM (TANDEM).....	94
44. HYDRAULIC BRAKING SYSTEM (TANDEM).....	96



45. BRAKE VALVE, COMPLETE - HALDEX.....	98
46. BRAKE VALVE, COMPLETE - KNORR.....	100
47. SUSPENSION TYPE - SPRINGS - PNEUMATIC BRAKES .....	102
48. SUSPENSION TYPE - TANDEM - PNEUMATIC BRAKES.....	104
49. SUSPENSION TYPE - TANDEM - PNEUMATIC BRAKES.....	106
50. SUSPENSION TYPE - TANDEM - HYDRAULIC BRAKES.....	108
51. SUSPENSION TYPE - TANDEM - HYDRAULIC BRAKES.....	110
52. HANDBRAKE, COMPLETE (N267/2).....	112
53. VERTICAL ADAPTOR, COMPLETE .....	114
54. LEFT AUGER, COMPLETE.....	116
55. NET LIFTING MECHANISM, COMPLETE.....	118
56. NET LIFTING MECHANISM, COMPLETE.....	120
57. GATE VALVE, COMPLETE .....	122
58. REAR SCRAPER FOR REAR ROLLER CHAIN WHEELS AND LUBRICATION.....	124
59. ELECTRIC SYSTEM .....	126
60. DEFLECTOR (SPREAD-LIMITING SCREEN).....	128
61. DEFLECTOR (SPREAD-LIMITING SCREEN).....	130
62. NOTES .....	132

# 1. HITCH AND SUPPORT FOOT

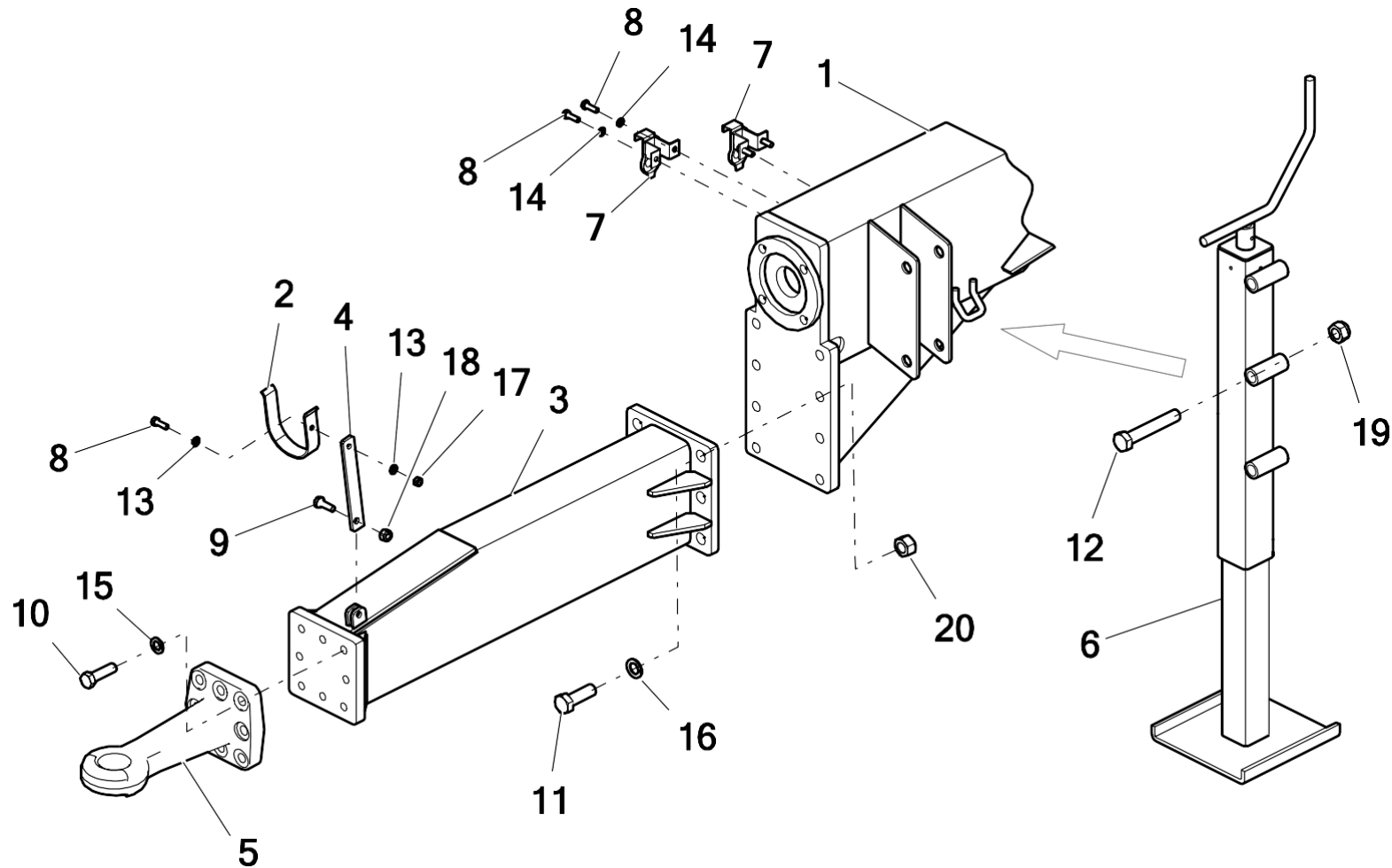

No.	Part or assembly name	Fig. or index No.					
		N267	Volume	N267/1	Volume	N267/2	Volume
1	Lower frame	N267 02.01.00	1	N267-1 02.01.00	1	N267-2 02.01.00	1
2	Support ear	N267 02.03.302	1	N267 02.03.302	1	N267 02.03.302	1
3*	Hitch adapter	N267 02.03.450	1	N267 02.03.450	1	N267 02.03.450	1
4	Arm of the shaft support	N267 02.03.405	1	N267 02.03.405	1	N267 02.03.405	1
5*	Hitch D50-C.B8.T45	POD-ODL-000054	1	POD-ODL-000054	1	POD-ODL-000054	1
6	Support foot – Spreader	POD-UGL-000372	1	POD-UGL-000372	1	POD-UGL-000372	1
7*	Pneumatic Connector Holder	POD-UGL-000573	2	POD-UGL-000573	2	POD-UGL-000573	2
8	Bolt 8 x 25 galv. 8.8 82105 82105	23S8/25OC8.8	5	23S8/25OC8.8	5	23S8/25OC8.8	5
9	Bolt 14 x 25 galv. 8.8 82105 82105	23S10/30 galv. 8.8	1	23S10/30 galv. 8.8	1	23S10/30 galv. 8.8	1
10	Bolt 16 x 55 galv. 10.9 82101	POD-ELZ-000418	8	POD-ELZ-000418	8	POD-ELZ-000418	8
11	Bolt 20 x 60 galv. 10.9 82101 82101	23S20/60 10.9	6	23S20/60 10.9	6	23S20/60 10.9	6
12	Bolt 20 x 120 galv. 8.8 82101 82101	23S20/120	2	23S20/120	2	23S20/120	2
13	Round washer 8 galv. 82005 82005	23P80OC	2	23P80OC	2	23P80OC	2
14	Spring washer 8.2 galv. 82008 82008	23P8SPOC	4	23P8SPOC	4	23P8SPOC	4
15	Spring washer 16.3 galv. 82008 82008	23P16SP	8	23P16SP	8	23P16SP	8

## 2. HITCH AND SUPPORT FOOT

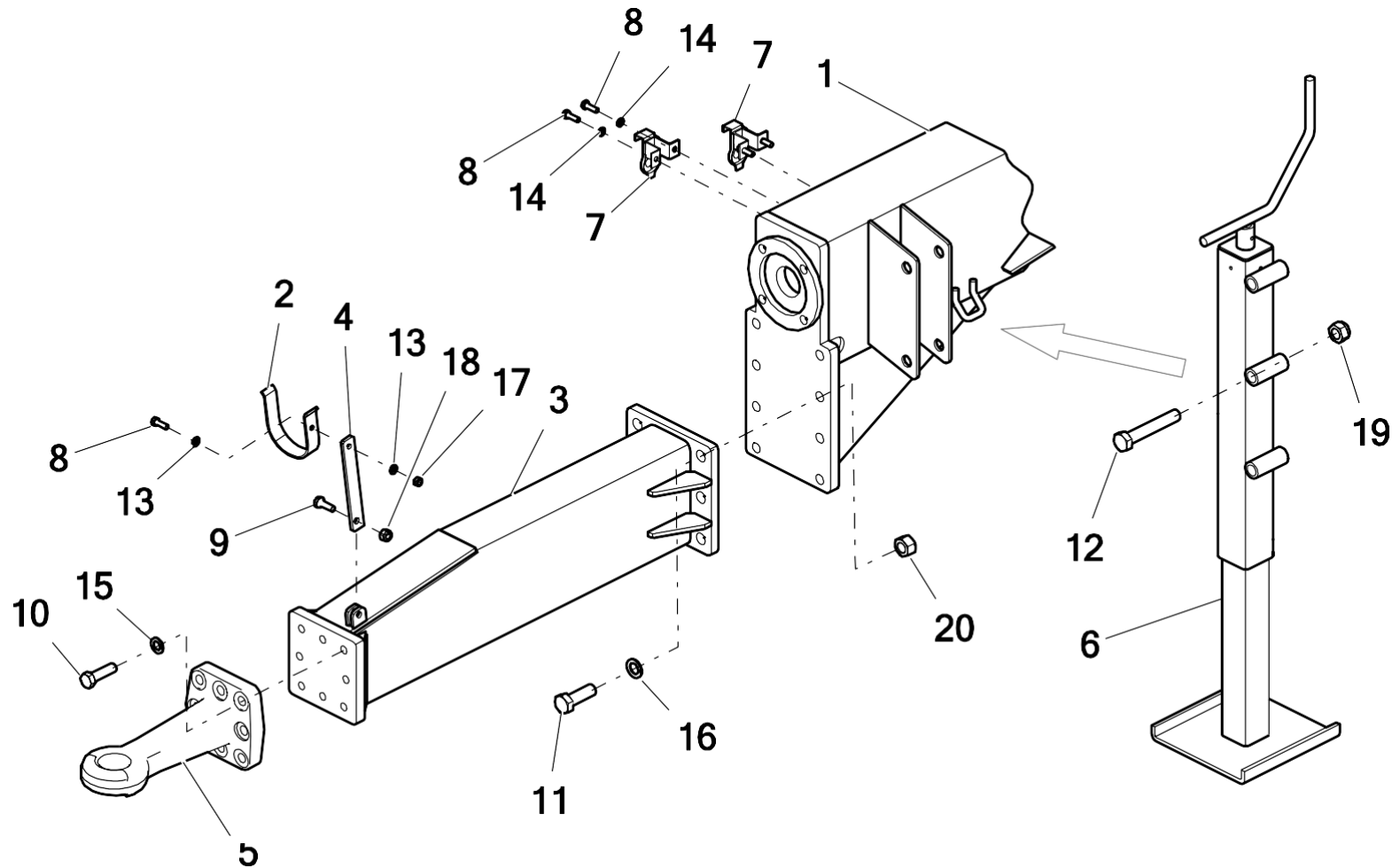

No.	Part or assembly name	Fig. or index No.					
		N267	Volume	N267/1	Volume	N267/2	Volume
16	Spring washer 20.5 galv. 82008 82008	23P20SP	6	23P20SP	6	23P20SP	6
17	Self-locking nut M8 galv. 82175 8 82175 8	23NS8OC	1	23NS8OC	1	23NS8OC	1
18	Self-locking nut M10 galv. 82175 8 82175 8	23NS10OC	1	23NS10OC	1	23NS10OC	1
19	Self-locking nut M20 galv. 82175 8 82175/8	23NS20OC 82175	2	23NS20OC 82175	2	23NS20OC 82175	2
20	Nut M20 galv. 82144 5	23N20OC	6	23N20OC	6	23N20OC	6

**Key:**

**3\*** - The N267 02.03.400 hitch adapter was used as a standard, until February 2019, while the N267 02.03.450 extended hitch adapter was used as an option, together with a wide-angle connecting articulated-telescopic shaft. **From February 2019 on, only the N267 02.03.450 extended hitch adapter is used.**

**5\*** - Also included as an OPTIONAL element:

**POD-ODL-000040** - D40-C.B6.T42 hitch (**Ø40 fixed drawbar eye**)

**POD-ODL-000048** - 00.652.43.0 hitch (**Ø50 rotary drawbar eye**)

**POD-ODL-000055** - 00 652.90.0 Ø80 ball hitch (**Ø80 rotary drawbar eye**)

**7\*** - this element is also included in the following sets:

- **POD-OGL-000513** - Braking system HALDEX / KNORR spreader N280 valves + connectors - as: **334028001 hook for cable connectors - 2 pieces**

- **POD-OGL-001094** - Braking system KNORR TUV type N all-purpose automatic regulator ALB valves without rear connectors - as: **Head holders - 2 pcs.**

### 3. WHEEL CHOCKS

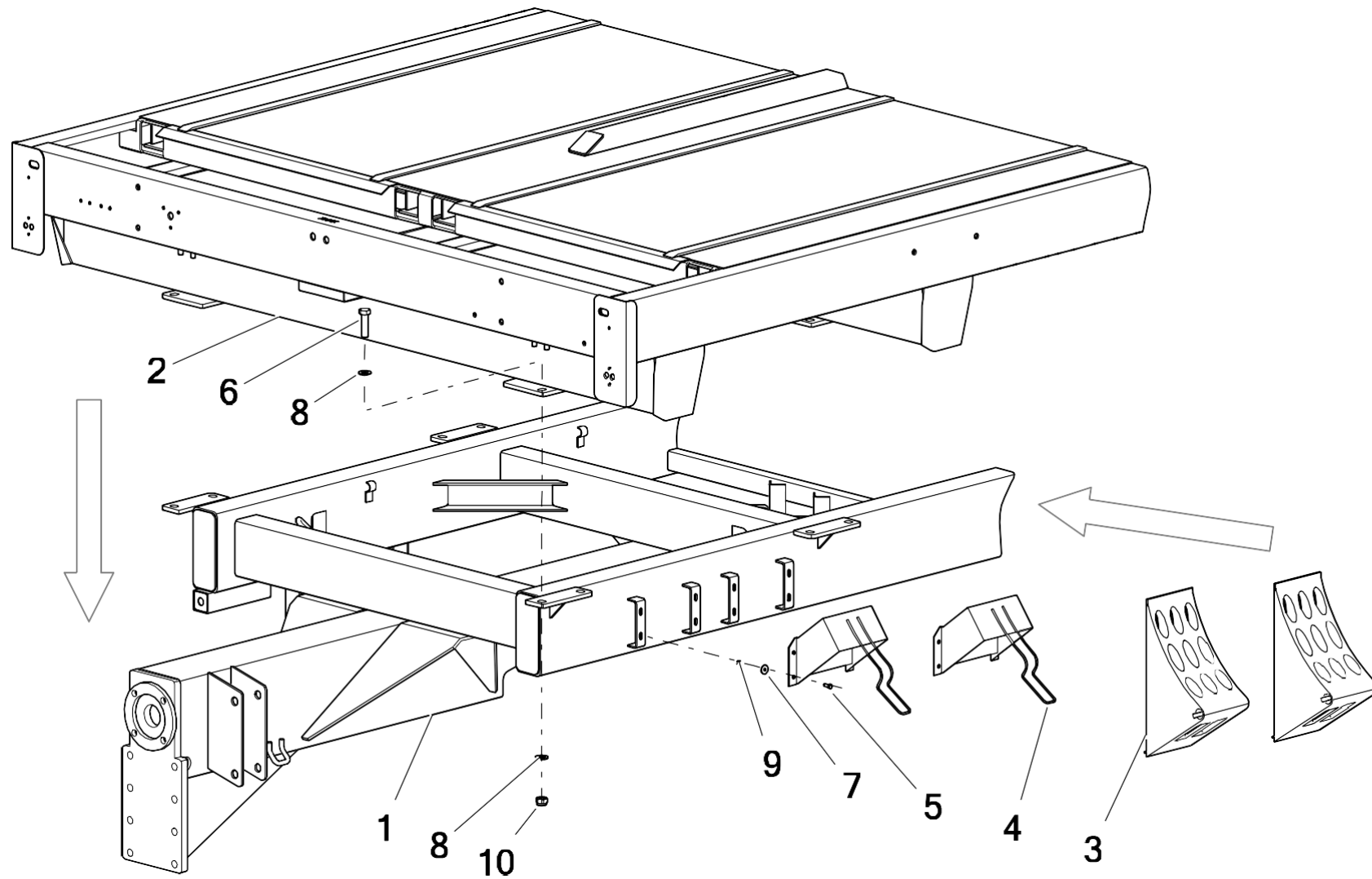

No.	Part or assembly name	Fig. or index No.					
		N267	Volume	N267/1	Volume	N267/2	Volume
1	Lower frame	N267 02.01.00	1	N267-1 02.01.00	1	N267-2 02.01.00	1
2	Top frame	N267 02.02.00.2	1	N267-1 02.02.00.2	1	N267-2 02/02/2000	1
3	Wheel chock	POD-OGL-000027-1	2	POD-OGL-000027-1	2	POD-OGL-000027-1	2
4	Chock grip	POD-OGL-000028-1	2	POD-OGL-000028-1	2	POD-OGL-000028-1	2
5	Round washer 6 galv. coated 82019	POD-ELZ-000563	8	POD-ELZ-000563	8	POD-ELZ-000563	8
6	Round washer 16 galv. 82005	23P160OC	40	23P160OC	28	23P160OC	40
7	Self-locking nut M6 galv. 82175 8	23NS6OC	8	23NS6OC	8	23NS6OC	8
8	Self-locking nut M16 galv. 82175/8	23NS16OC	20	23NS16OC	14	23NS16OC	20
9	Bolt 6 x 16 galv. 8.8 82105	23S6/16 8.8OC	8	23S6/16 8.8OC	8	23S6/16 8.8OC	8
10	Bolt 16 x 55 galv. 8.8 82101	POD-ELZ-000733	20	POD-ELZ-000733	14	POD-ELZ-000733	20



#### 4. LADDER

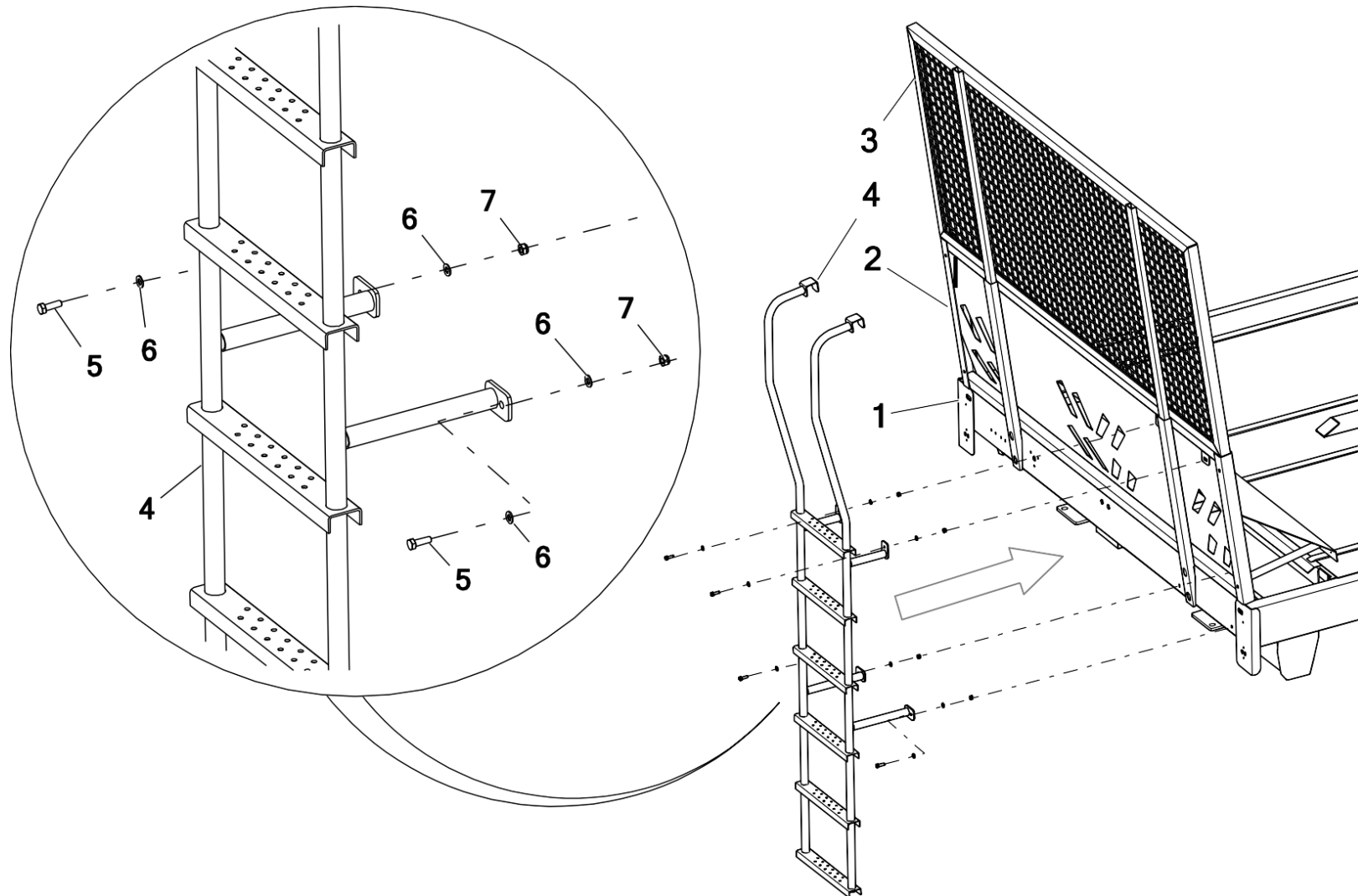

No.	Part or assembly name	Fig. or index No.					
		N267	Volume	N267/1	Volume	N267/2	Volume
1	Top frame	N267 02.02.00.2	1	N267-1 02.02.00.2	1	N267-2 02/02/2000	1
2	Front panel, complete	N267 03.00.00.1	1	N267 03.00.00.1	1	N267 03.00.00.1	1
3	Front mesh, complete	N267 06.00.00	1	N267 06.00.00	1	N267 06.00.00	1
4	Ladder	N267 07.00.00.1	1	N267 07.00.00.1	1	N267 07.00.00.1	1
5	Bolt 8 x 25 galv. 8.8 82105 82105	23S8/25OC8.8	4	23S8/25OC8.8	4	23S8/25OC8.8	4
6	Round washer 8 galv. 82005 82005	23P80OC	8	23P80OC	8	23P80OC	8
7	Self-locking nut M8 galv. 82175 8 82175 8	23NS8OC	4	23NS8OC	4	23NS8OC	4

## 5. FRONT PANEL, SIDE PANELS AND MESH

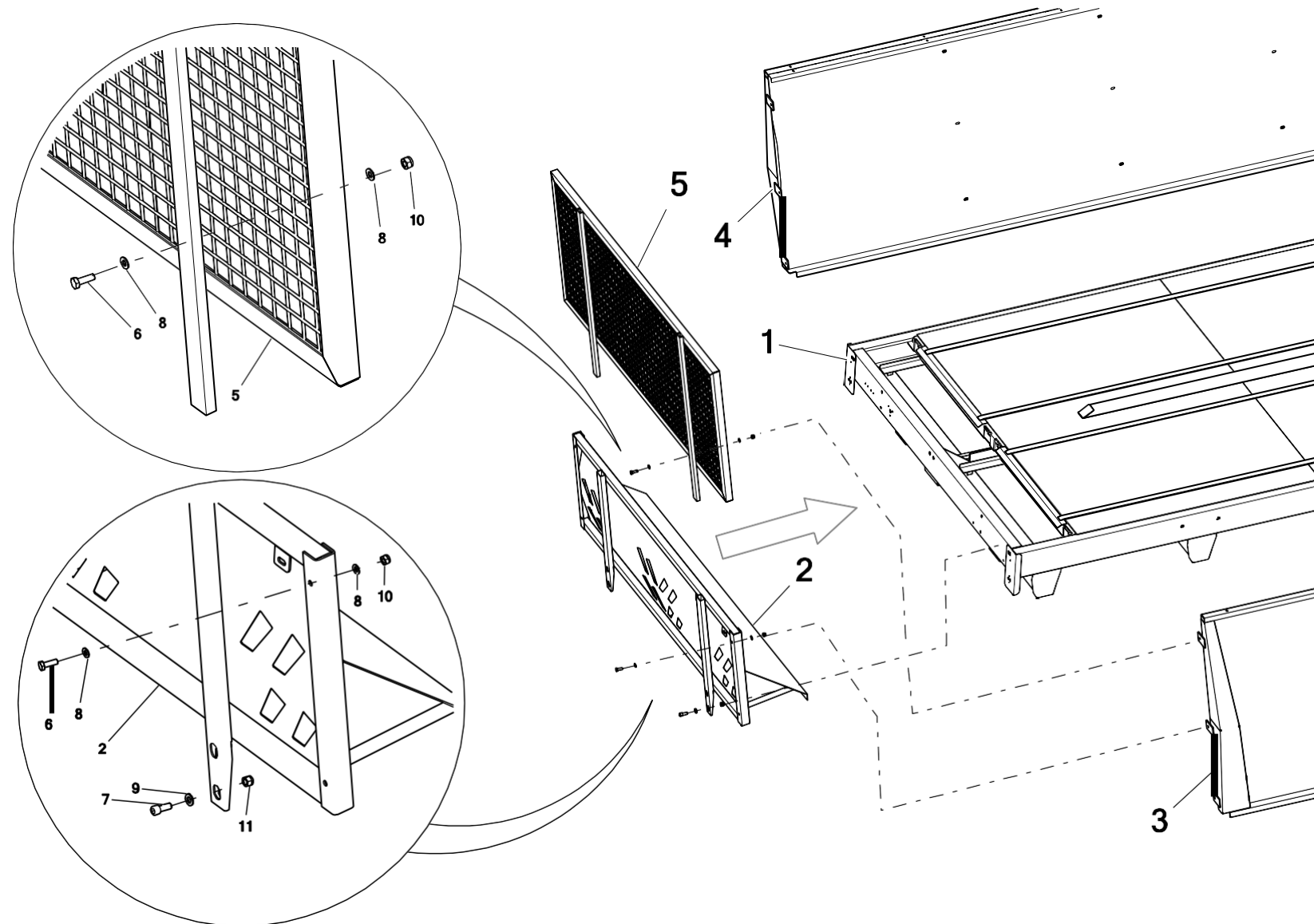

No.	Part or assembly name	Fig. or index No.					
		N267	Volume	N267/1	Volume	N267/2	Volume
1	Top frame	N267 02.02.00.2	1	N267-1 02.02.00.2	1	N267-2 02/02/2000	1
2	Front panel, complete	N267 03.00.00.1	1	N267 03.00.00.1	1	N267 03.00.00.1	1
3	Left panel, complete	N267 04.00.00	1	N267-1 04.00.00	1	N267-2 04.00.00	1
4	Right panel, complete	N267 05.00.00	1	N267-1 05.00.00	1	N267-2 05.00.00	1
5	Front mesh, complete	N267 06.00.00	1	N267 06.00.00	1	N267 06.00.00	1
6	Bolt 10 x 30 galv. 8.8 82105 82105	23S10/30OC 8	6	23S10/30 galv. 8	6	23S10/30 galv. 8	6
7	Allen bolt 12 x 30 galv. 8.8 82302	POD-ELZ-000710	4	POD-ELZ-000710	4	POD-ELZ-000710	4
8	Round washer 10 galv. 82005 82005	23P10 82005	12	23P10 82005	12	23P10 82005	12
9	Round washer 12 galv. 82005 82005	23P12OC	4	23P12OC	4	23P12OC	4
10	Self-locking nut M10 galv. 82175 8 82175 8	23NS10OC	6	23NS10OC	6	23NS10OC	6
11	Self-locking nut M12 galv. cl. 8, DIN 982	POD-ELZ-000613	4	POD-ELZ-000613	4	POD-ELZ-000613	4

**6. FRONT PANEL**

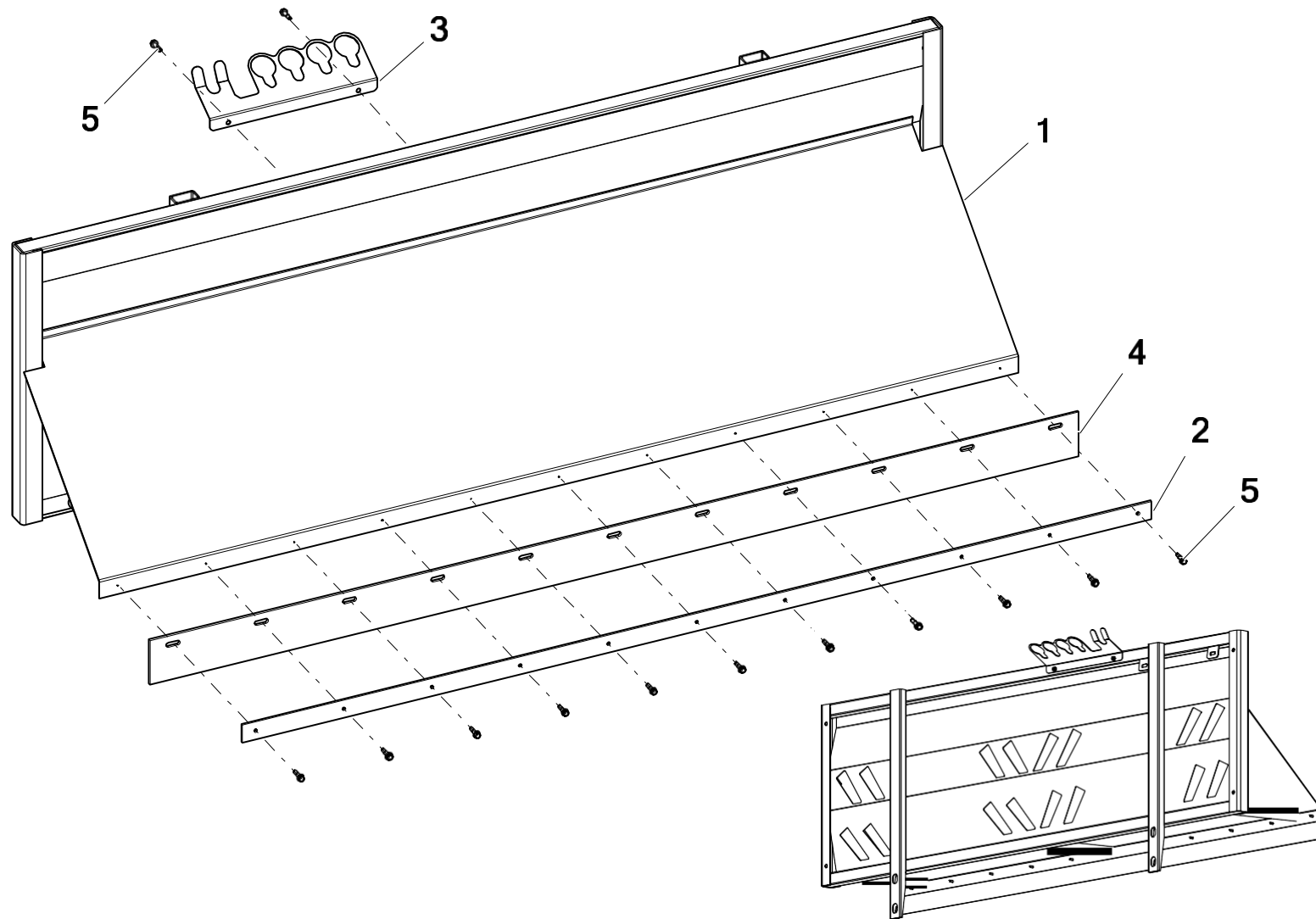

No.	Part or assembly name	Fig. or index No.					
		N267	Volume	N267/1	Volume	N267/2	Volume
1	Front panel, complete	N267 03.00.00.1	1	N267 03.00.00.1	1	N267 03.00.00.1	1
2	Rubber mounting	N267 03.00.06	1	N267 03.00.06	1	N267 03.00.06	1
3	Hook for cables	N267 03.00.10	1	N267 03.00.10	1	N267 03.00.10	1
4	Rubber belt 2000 x 1000 / spreaders /	POD-TSZ-000056	1	POD-TSZ-000056	1	POD-TSZ-000056	1
5	Self-drilling screw 6.3 x 25 galv. head with key	28W6.3x25OC	13	28W6.3x25OC	13	28W6.3x25OC	13

## 7. STAKES AND SIDE PANELS

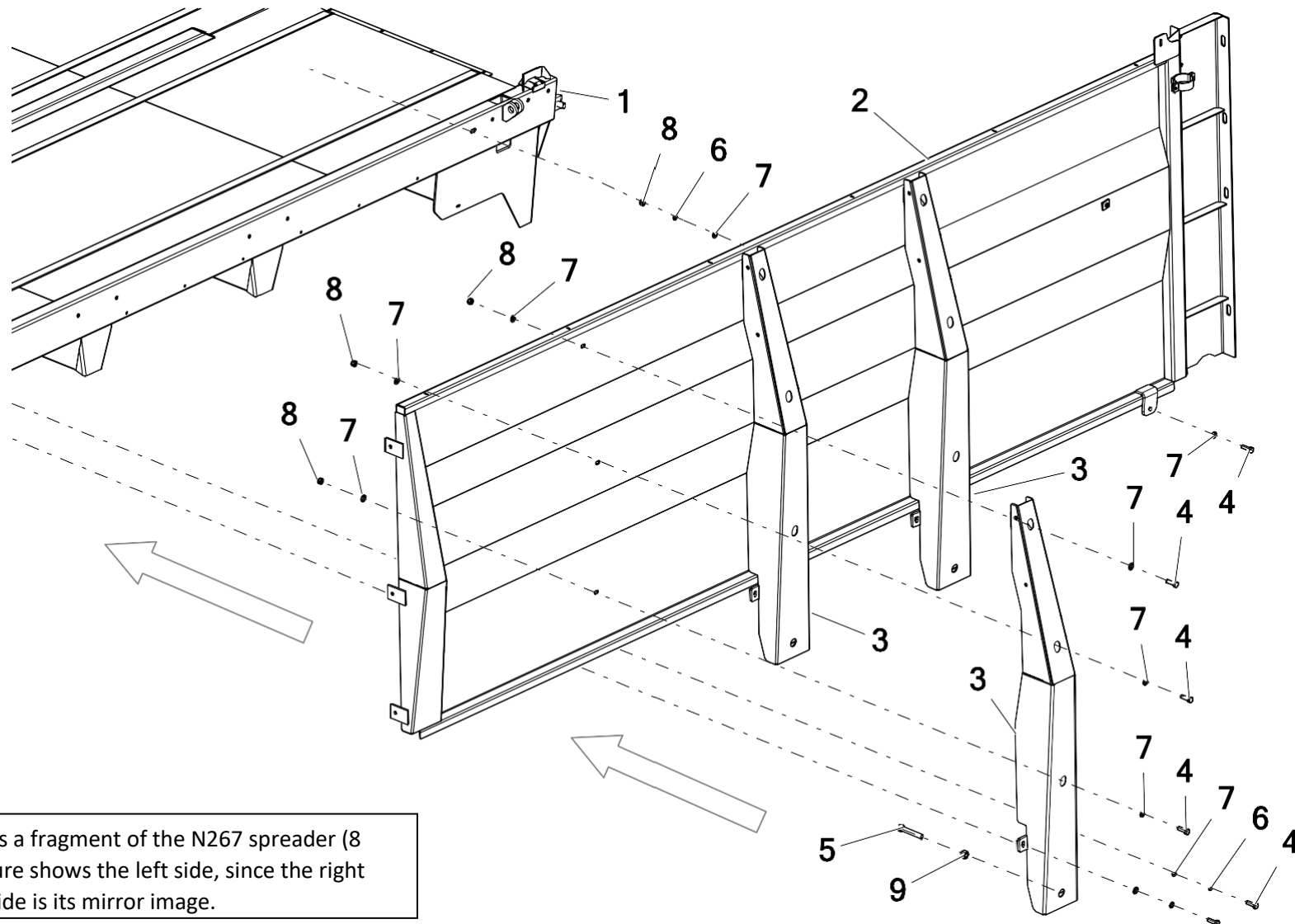

The figure shows a fragment of the N267 spreader (8 tonnes). The figure shows the left side, since the right side is its mirror image.



No.	Part or assembly name	Fig. or index No.					
		N267	Volume	N267/1	Volume	N267/2	Volume
1	Top frame	N267 02.02.00.2	1	N267-1 02.02.00.2	1	N267-2 02/02/2000	1
2	Left panel	N267 04.00.00.2	1	N267-1 04.00.00.2	1	N267-2 04.00.00	1
	Right panel	N267 05.00.00.2	1	N267-1 05.00.00.2	1	N267-2 05.00.00	1
3	Left stake	N267 04.10.00.2L	3	N267 04.10.00.2L	2	N267-2 04.10.00L	3
	Right stake	N267 04.10.00.2P	3	N267 04.10.00.2P	2	N267-2 04.10.00P	3
4	Bolt 12 x 35 galv. 8.8 82105 82105	23S12/35OC 8.8	32	23S12/35OC 8.8	22	23S12/35OC 8.8	32
5	Bolt 16 x 90 galv. 10.9 82101	POD-ELZ-000497	6	POD-ELZ-000497	4	POD-ELZ-000497	6
6	Spring washer 12 galv. 82008 82008	23P12SP	14	23P12SP	10	23P12SP	14
7	Round washer 12 galv. 82005 82005	23P12OC	52	23P12OC	36	23P12OC	52
8	Self-locking nut M12 galv. 82175 8 82175 8	23NS12OC	20	23NS12OC	14	23NS12OC	20
9	Nut M16 galv. 8.8 82144 5 82144 5	23N16OC	6	23N16OC	4	23N16OC	6

## 8. END OF THE PANEL.

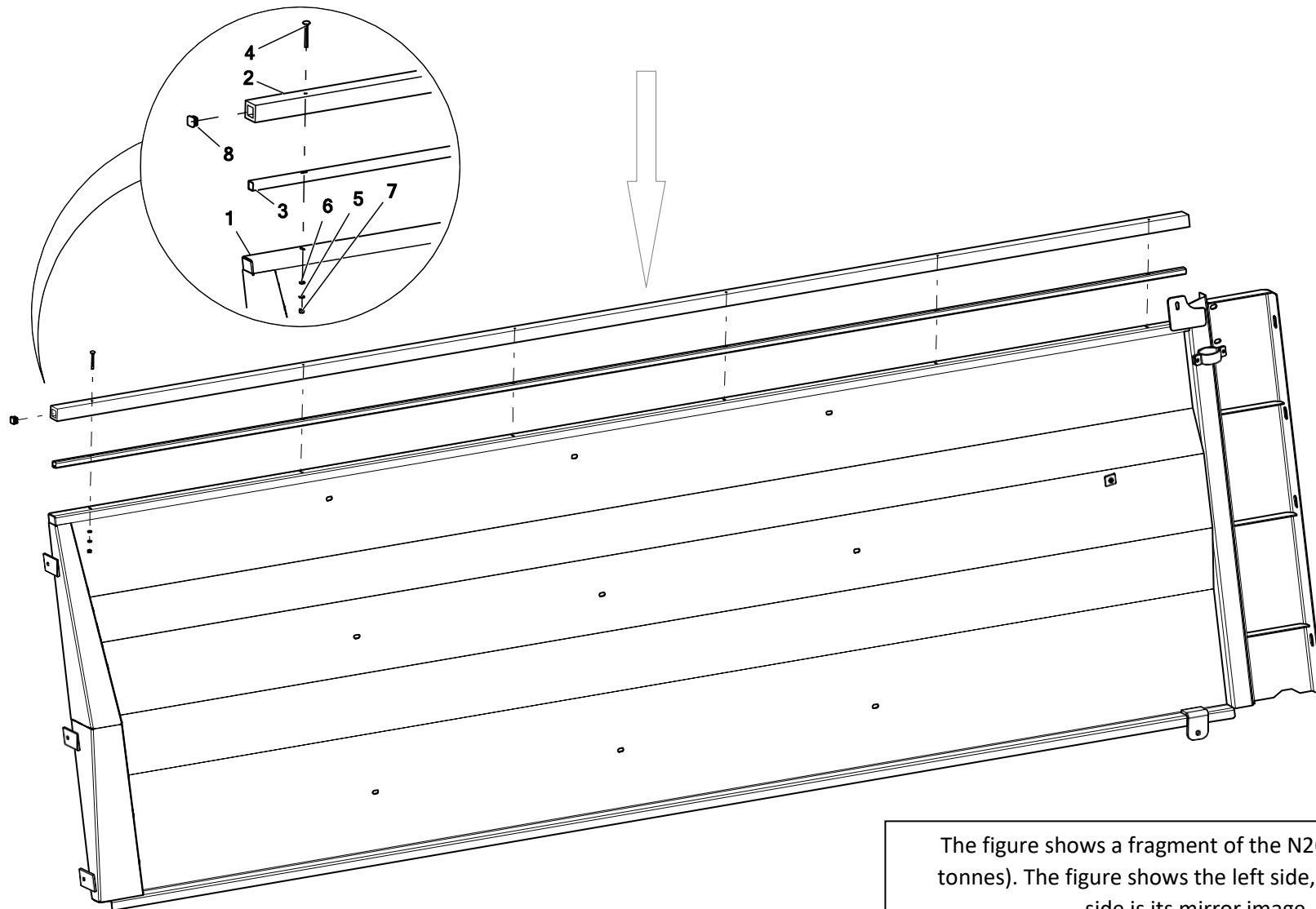

The figure shows a fragment of the N267 spreader (8 tonnes). The figure shows the left side, since the right side is its mirror image.

No.	Part or assembly name	Fig. or index No.					
		N267	Volume	N267/1	Volume	N267/2	Volume
1	Left panel	N267 04.00.00.2	1	N267-1 04.00.00.2	1	N267-2 04.00.00	1
	Right panel	N267 05.00.00.2	1	N267-1 05.00.00.2	1	N267-2 05.00.00	1
2	End of the panel	N267 04/11/2001	2	N267-1 04/11/2001	2	N267 04/11/2001	2
3	Internal section	N267 04/11/2002	2	N267-1 04/11/2002	2	N267 04/11/2002	2
4	Carriage bolt 6 x 55 galv. 8.8 82406	POD-ELZ-000654	12	POD-ELZ-000654	10	POD-ELZ-000654	12
5	Spring washer 6.1 galv. 82008 82008	23P6SPOC	12	23P6SPOC	10	23P6SPOC	12
6	Round washer 6 galv. 82005 82005	23P60OC	12	23P60OC	10	23P60OC	12
7	Nut M6 galv. 82144 5 82144 5	23N6OC	12	23N6OC	10	23N6OC	12
8	Internal stopper 20 x 20 x 0.8-2.5 black (Es-111215)	POD-TSZ-000269	2	POD-TSZ-000269	2	POD-TSZ-000269	2

### 9. METAL SHEET EXTENSIONS.

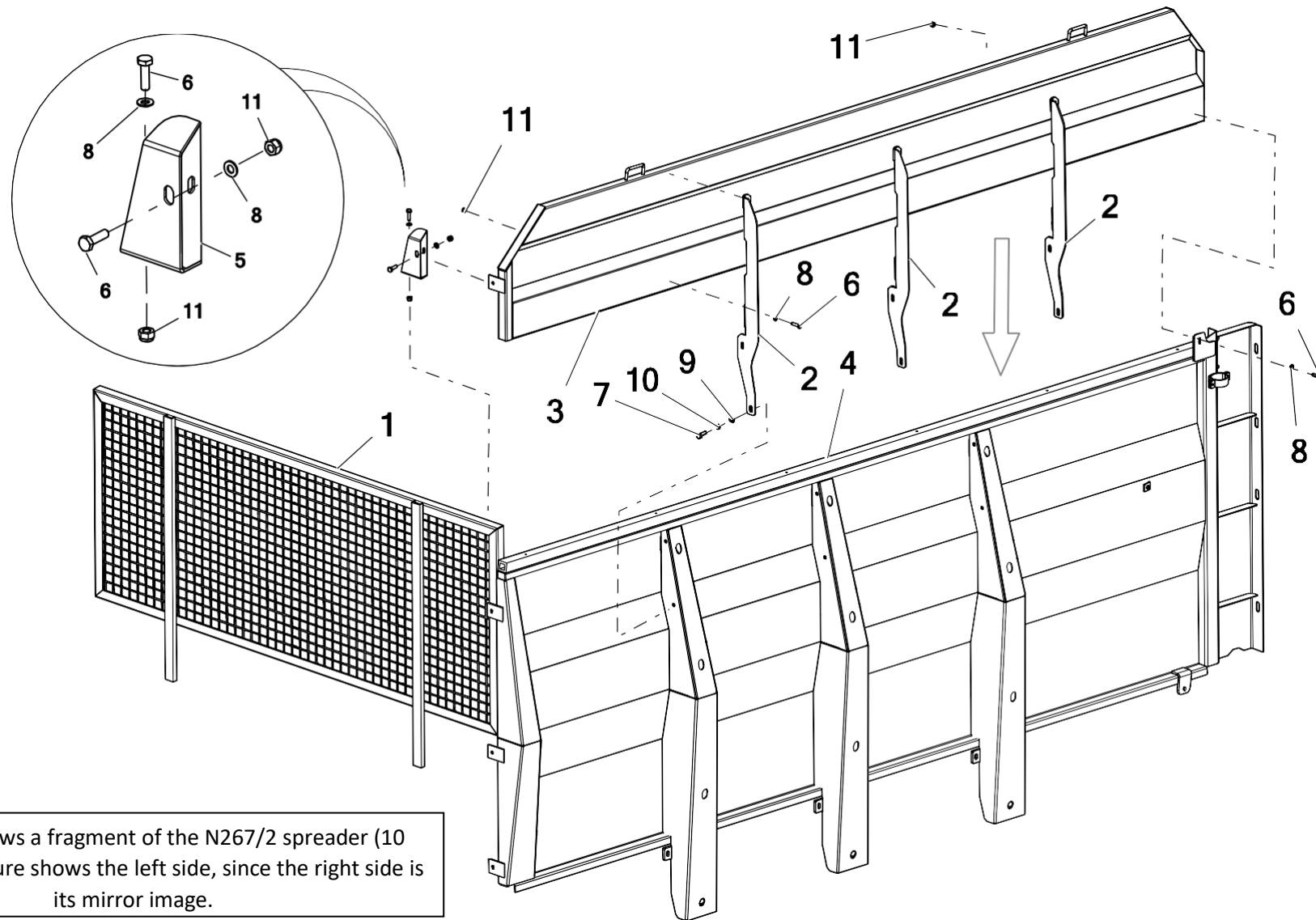

The figure shows a fragment of the N267/2 spreader (10 tonnes). The figure shows the left side, since the right side is its mirror image.

No.	Part or assembly name	Fig. or index No.					
		N267	Volume	N267/1	Volume	N267/2	Volume
1	Front mesh, complete	N267 06.00.00	1	N267 06.00.00	1	N267 06.00.00	1
2	Left extension stake	N267 11.00.02L	3	N267-1 11.00.02L	2	N267 11.00.02L	3
	Right extension stake	N267 11.00.02P	3	N267-1 11.00.02L	2	N267 11.00.02L	3
3	Left extension, complete	N267 11.01.00.2	1	N267-1 11.01.00.2	1	N267 11.01.00.2	1
	Right extension, complete	N267 12.01.00.2	1	N267-1 12.01.00.2	1	N267 12.01.00.2	1
4	Left panel, complete	N267 04.00.00.2	1	N267-1 04.00.00.2	1	N267-2 04.00.00	1
	Right panel, complete	N267 05.00.00.2	1	N267-1 05.00.00.2	1	N267-2 05.00.00	1
5	Front left extension mounting	-----	----	-----	----	N267-2 11.02.00L	1
	Right front mounting of the right extension	-----	----	-----	----	N267-2 11.02.00P	1
6	Bolt 10 x 35 galv. 10.9 82105	POD-ELZ-000830	18	POD-ELZ-000830	12	POD-ELZ-000830	18
7	Bolt 12 x 35 galv. 8.8 82105 82105	23S12/35OC8.8	12	23S12/35OC8.8	10	23S12/35OC8.8	12
8	Round washer 10 galv. 82005	23P10 82005	18	23P10 82005	12	23P10 82005	18
9	Round washer 12 galv. 82005	23P12OC	12	23P12OC	10	23P12OC	12
10	Spring washer 12 galv. 82008	23P12SP	12	23P12SP	10	23P12SP	12
11	Self-locking nut M10 galv. 82175 8 82175 8	23NS10OC	18	23NS10OC	12	23NS10OC	18

**Key:**

Items 2 and 3 are also included as: **N267 11.00.00.1 left extension with stakes** and **N267 12.00.00.1 right extension with stakes**

### 10. NET EXTENSIONS

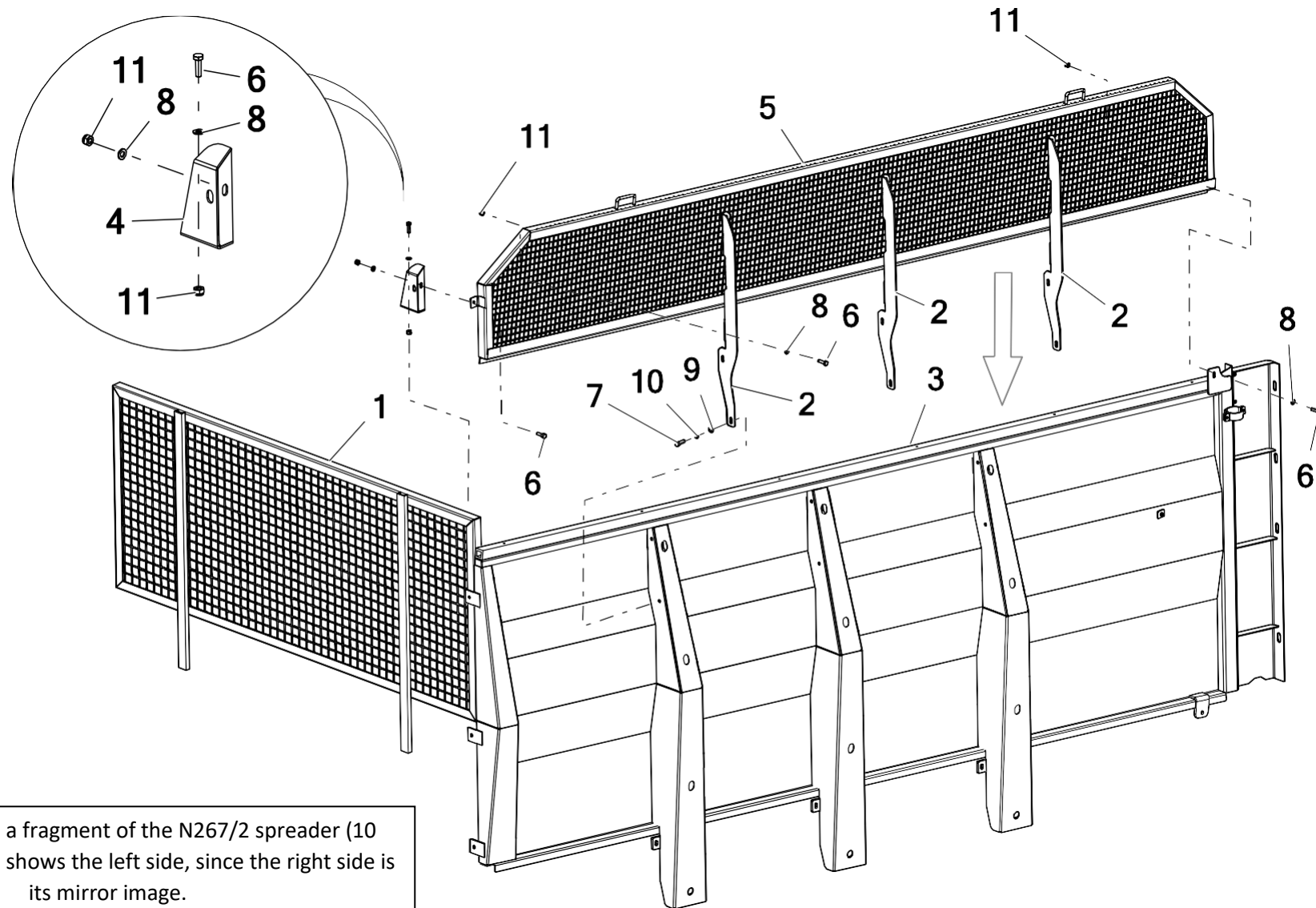

The figure shows a fragment of the N267/2 spreader (10 tonnes). The figure shows the left side, since the right side is its mirror image.

No.	Part or assembly name	Fig. or index No.					
		N267	Volume	N267/1	Volume	N267/2	Volume
1	Front mesh, complete	N267 06.00.00	1	N267 06.00.00	1	N267 06.00.00	1
2	Left extension stake	N267 11.00.02L	3	N267-1 11.00.02L	2	N267 11.00.02L	3
	Right extension stake	N267 11.00.02L	3	N267-1 11.00.02L	2	N267 11.00.02L	3
3	Left panel, complete	N267 04.00.00	1	N267-1 04.00.00	1	N267-2 04.00.00	1
	Right panel, complete	N267 05.00.00	1	N267-1 05.00.00	1	N267-2 05.00.00	1
4	Front left extension mounting	-----	----	-----	----	N267-2 11.02.00L	1
	Right front mounting of the right extension	-----	----	-----	----	N267-2 11.02.00P	1
5	Left mesh extension	N267 21.01.00.1	1	N267-1 21.01.00.1	1	N267 21.01.00.1	1
	Right mesh extension	N267 22.01.00.1	1	N267-1 22.01.00.1	1	N267 22.01.00.1	1
6	Bolt 10 x 35 galv. 10.9 82105	POD-ELZ-000830	18	POD-ELZ-000830	12	POD-ELZ-000830	18
7	Bolt 12 x 35 galv. 8.8 82105	23S12/35OC8.8	12	23S12/35OC8.8	8	23S12/35OC8.8	12
8	Round washer 10 galv. 82005	23P10 82005	18	23P10 82005	12	23P10 82005	18
9	Round washer 12 galv. 82005	23P12OC	12	23P12OC	8	23P12OC	12
10	Spring washer 12 galv. 82008	23P12SP	12	23P12SP	8	23P12SP	12
11	Self-locking nut M10 galv. 82175 8 82175 8	23NS10OC	18	23NS10OC	12	23NS10OC	18

**Key:**

**Items 2 and 5 are also included as: Left mesh extension, complete N267 21.00.00.1 and right mesh extension, complete N267 22.00.00.1**



# 11. MUDGUARD

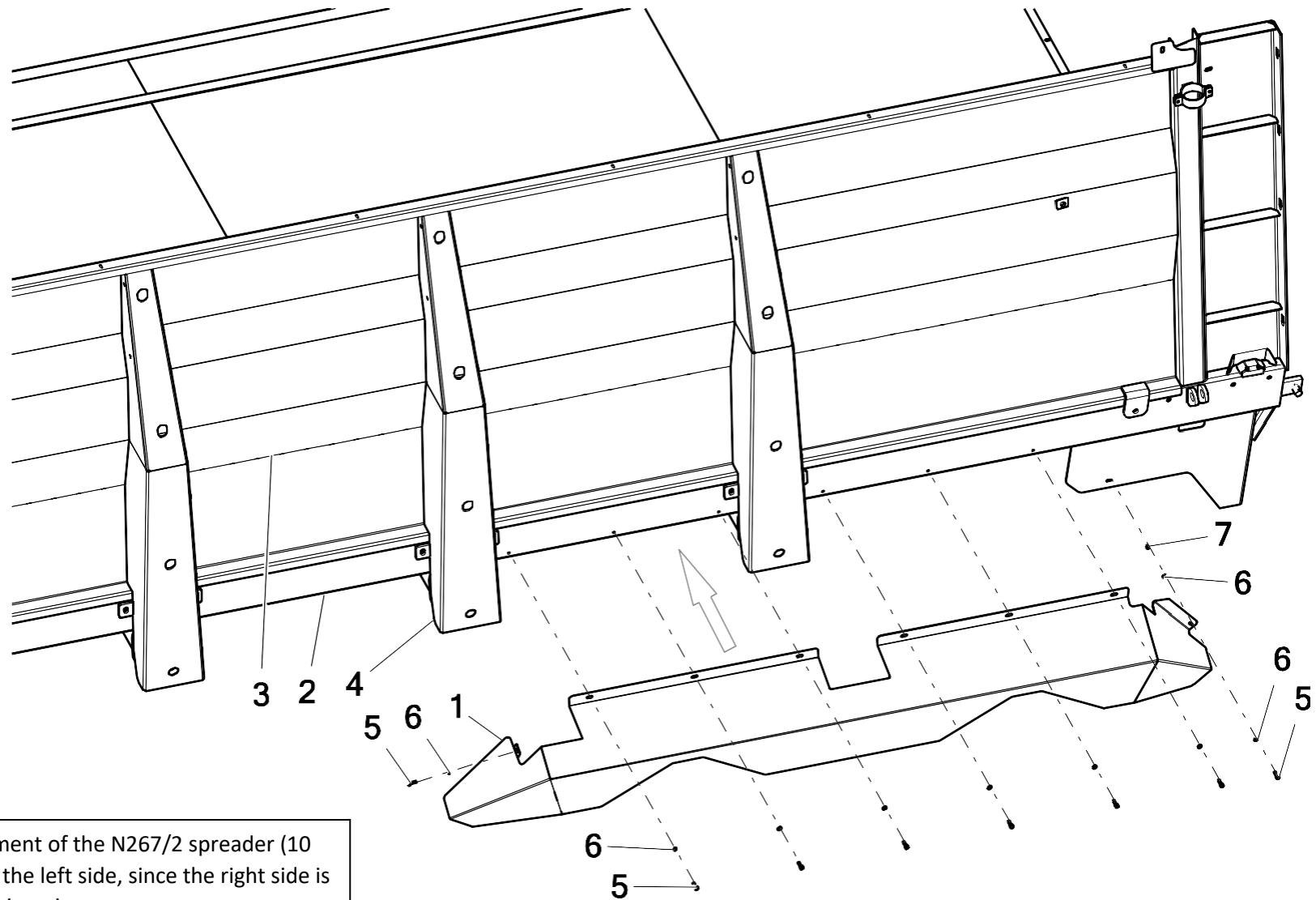

The figure shows a fragment of the N267/2 spreader (10 tonnes). The figure shows the left side, since the right side is its mirror image.

No.	Part or assembly name	Fig. or index No.					
		N267	Volume	N267/1	Volume	N267/2	Volume
1	Left mudguard, complete	N267 02.12.00L	1	N267-1 02.12.00.1L	1	N267 02.12.00L	1
	Right mudguard, complete	N267 02.12.00P	1	N267-1 02.12.00.1P	1	N267 02.12.00P	1
2	Top frame	N267 02/02/2000	1	N267-1 02/02/2000	1	N267-2 02/02/2000	1
3	Left panel, complete	N267 04.00.00.2	1	N267-1 04.00.00.2	1	N267-2 04.00.00	1
	Right panel, complete	N267 05.00.00.2	1	N267-1 05.00.00.2	1	N267-2 05.00.00	1
4	Left stake, complete	N267 04.10.00L	3	N267-1 04.10.00L	2	N267-2 04.10.00L	3
	Right stake	N267 11.00.02L	3	N267-1 11.00.02L	2	N267 11.00.02L	3
5	Bolt 6 x 20 galv. 8.8 82105 8 82105 8	23S6/20	16	23S6/20	12	23S6/20	16
6	Round washer 6 galv. 82005 82005	23P0OC	18	23P0OC	16	23P0OC	18
7	Self-locking nut M6 galv. 82175 8 82175 8	23NS6OC	2	23NS6OC	2	23NS6OC	2

**12. REAR GUARD**

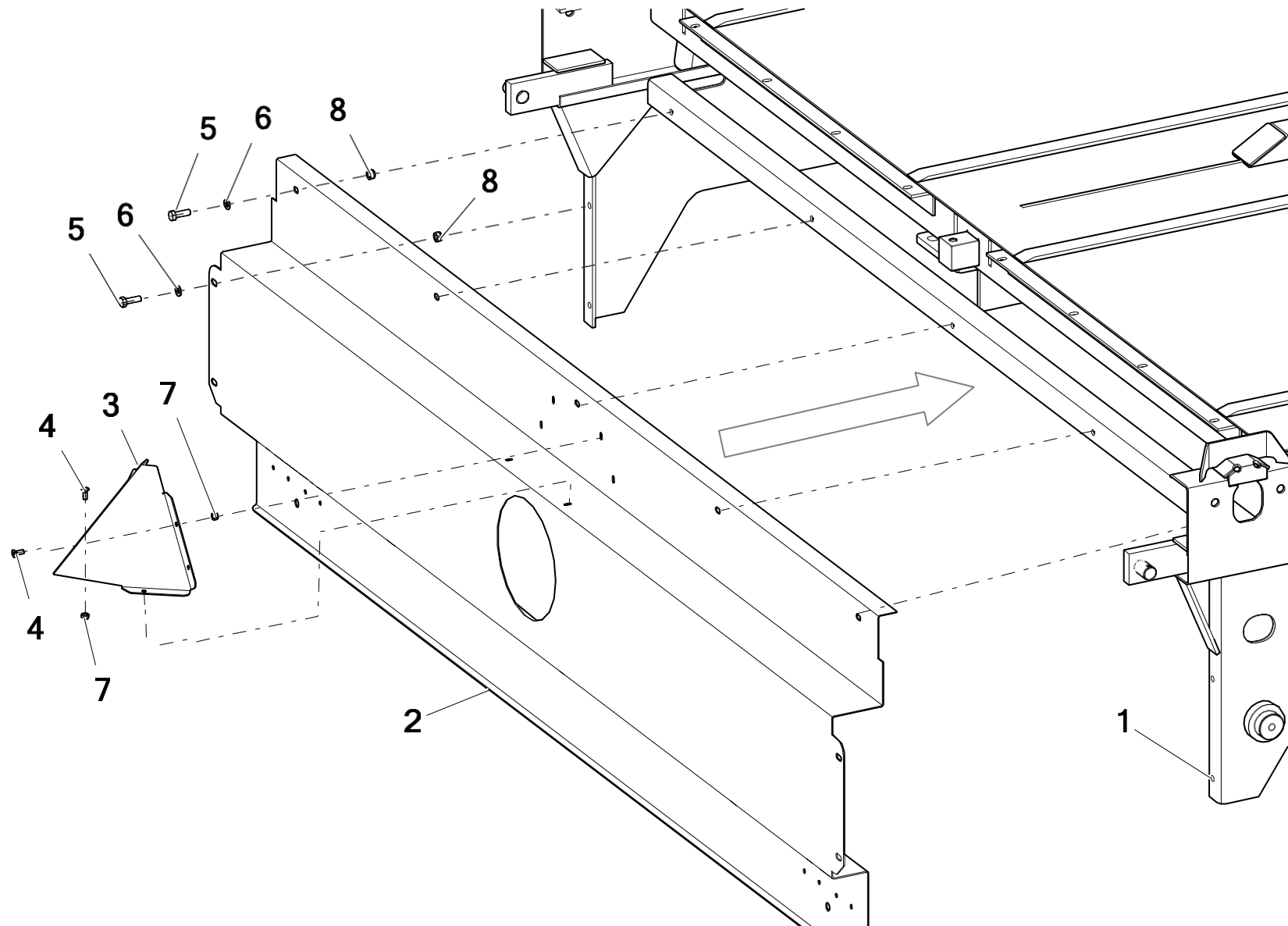

No.	Part or assembly name	Fig. or index No.					
		N267	Volume	N267/1	Volume	N267/2	Volume
1	Top frame	N267 02.02.00.2	1	N267-1 02.02.00.2	1	N267-2 02/02/2000	1
2	Lower guard	N267 02.02.13.6	1	N267 02.02.13.6	1	N267 02.02.13.6	1
3	Centre metal sheet	N267 02.02.14.1	1	N267 02.02.14.1	1	N267 02.02.14.1	1
4	Screw 6 x 16 galv. 82208	23W6/16	4	23W6/16	4	23W6/16	4
5	Bolt 8 x 25 galv. 8.8 82105	23S8/25OC8.8	11	23S8/25OC8.8	11	23S8/25OC8.8	11
6	Round washer 8 galv. 82005 82005	23P80OC	11	23P80OC	11	23P80OC	11
7	Self-locking nut M6 galv. 82175 8 82175 8	23NS6OC	6	23NS6OC	6	23NS6OC	6
8	Self-locking nut M8 galv. 82175 8 82175 8	23NS8OC	11	23NS8OC	11	23NS8OC	11

### 13. FLOOR CONVEYOR

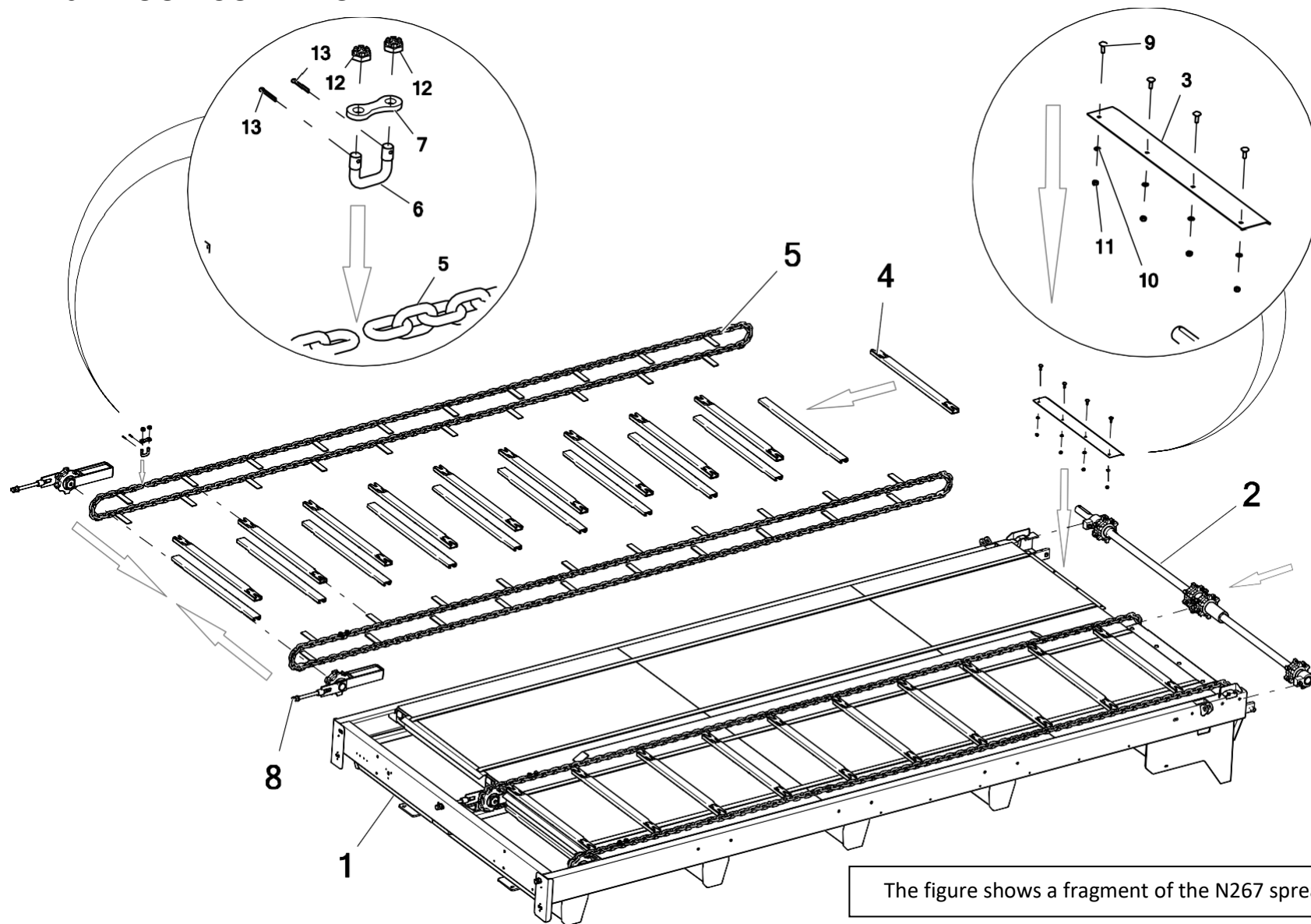

The figure shows a fragment of the N267 spreader (8 tonnes)

No.	Part or assembly name	Fig. or index No.					
		N267	Volume	N267/1	Volume	N267/2	Volume
1	Top frame	N267 02.02.00.2	1	N267-1 02.02.00.2	1	N267-2 02/02/2000	1
2	Rear drive shaft, complete	N267 02.02.100.1	1	N267 02.02.100.1	1	N267 02.02.100.1	1
3	Sheet metal shaft guard	N267 02.02.131	2	N267 02.02.131	2	N267 02.02.131	2
4	Conveyor bar, complete	N267 02.10.10.1	46	N267 02.10.10.1	40	N267 02.10.10.1	46
5	Floor conveyor chain	N267 02/10/2020	4	N267-1 02/10/2020	4	N267 02/10/2020	4
6	NK11 chain connector with a clevis holder	N267 02.10.22.2	4	N267 02.10.22.2	4	N267 02.10.22.2	4
7	Plate	N267 02.10.23.2	4	N267 02.10.23.2	4	N267 02.10.23.2	4
8	Tensioner, complete	N267 02/02/1980	4	N267 02/02/1980	4	N267 02/02/1980	4
9	Carriage bolt 8 x 25 galv. 8.8 82406 82406	23S8/25OC 82406	8	23S8/25OC 82406	8	23S8/25OC 82406	8
10	Round washer 8 galv. 82005 82005	23P8OOC	8	23P8OOC	8	23P8OOC	8
11	Self-locking nut M8 galv. 82175 8 82175 8	23NS8OC	4	23NS8OC	4	23NS8OC	4
12	Low profile castellated nut M12 galv. 82159	POD-ELZ-000841	8	POD-ELZ-000841	8	POD-ELZ-000841	8
13	Cotter pin 3.2 x 25 galv.	23Z32/25OC	8	23Z32/25OC	8	23Z32/25OC	8

**14. TENSIONER, COMPLETE**

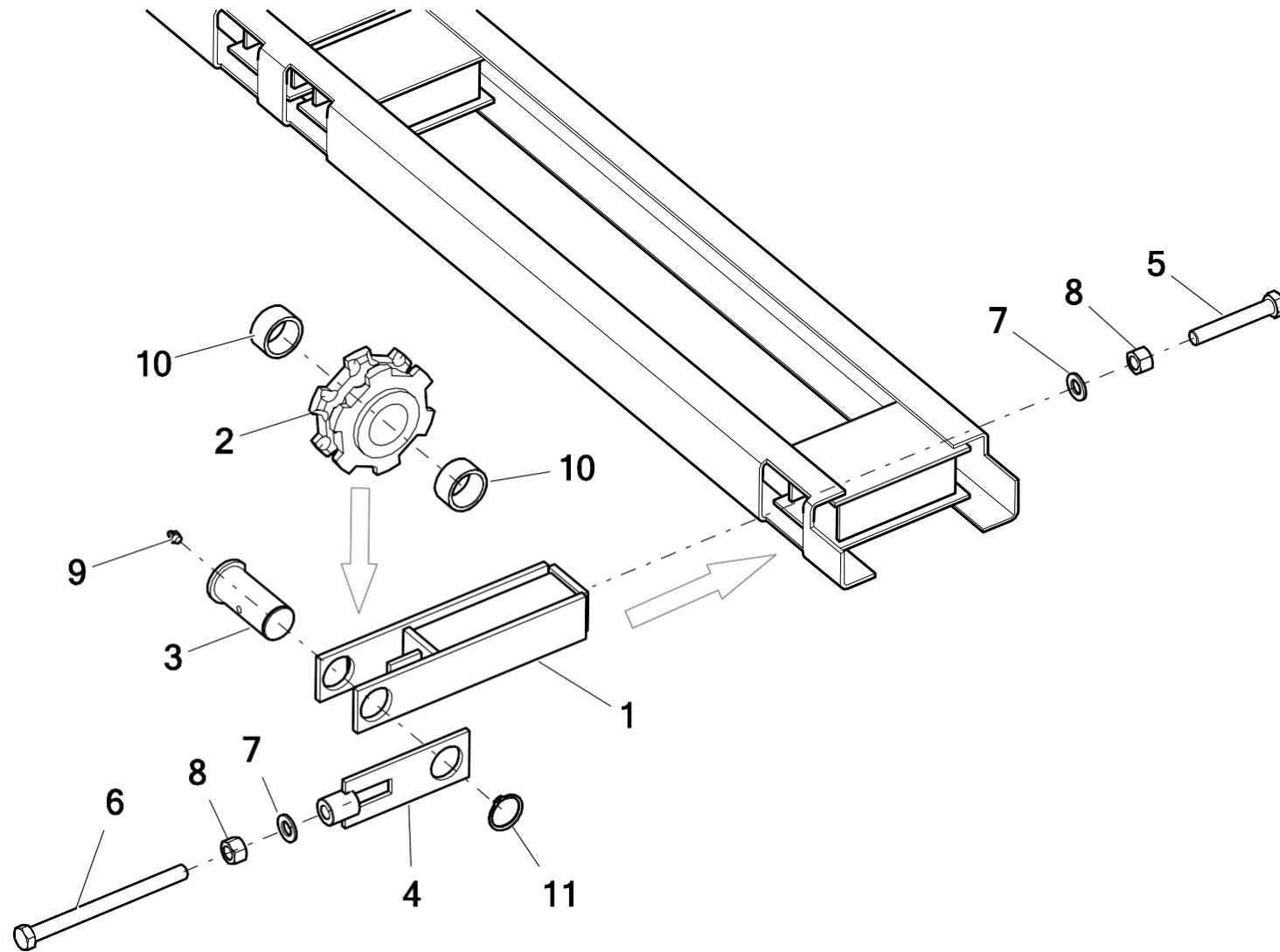



No.	Part or assembly name	Fig. or index No.					
		N267	Volume	N267/1	Volume	N267/2	Volume
1	Tensioning device, complete	N267 02.02.60.1	4	N267 02.02.60.1	4	N267 02.02.60.1	4
2	Chain wheel II	N267 02/02/1961	4	N267 02/02/1961	4	N267 02/02/1961	4
3	Chain wheel pin	N267 02.02.63.1	4	N267 02.02.63.1	4	N267 02.02.63.1	4
4	Tensioner	N267 02/02/1980	4	N267 02/02/1980	4	N267 02/02/1980	4
5	Bolt 16 x 100 galv. 8.8 82105 82105	23S16/100OC 8.8	4	23S16/100OC 8.8	4	23S16/100OC 8.8	4
6	Bolt 16 x 200 galv. 8.8 82105 82105	POD-ELZ-000370	4	POD-ELZ-000370	4	POD-ELZ-000370	4
7	Round washer 16 galv. 82005 82005	23P16OOC	8	23P16OOC	8	23P16OOC	8
8	Nut M16 galv. 8.8 82144 5 82144 5	23N16OC	8	23N16OC	8	23N16OC	8
9	Lubricating nipple M10 x 1.0 straight	23SM10/1	4	23SM10/1	4	23SM10/1	4
10	Self-lubricating sleeve 40H8/50R7x25	25T40/50/25	8	25T40/50/25	8	25T40/50/25	8
11	Seeger circlip Z38	23SZ38	4	23SZ38	4	23SZ38	4

### 15. REAR SHAFT, COMPLETE

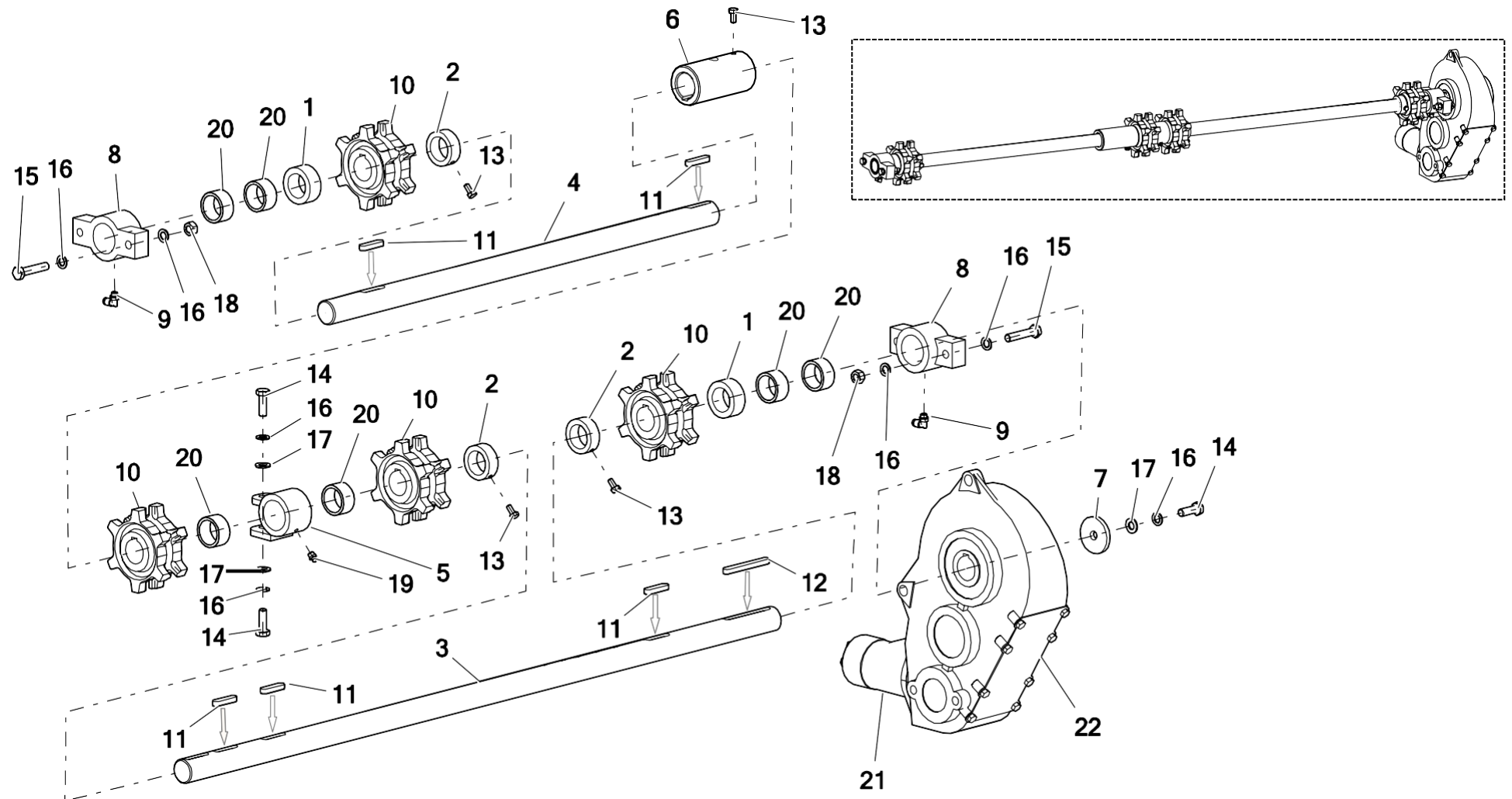

No.	Part or assembly name	Fig. or index No.					
		N267	Volume	N267/1	Volume	N267/2	Volume
1	Spacer	N267 02.02.103.2	2	N267 02.02.103.2	2	N267 02.02.103.2	2
2	Pressure bushing	N267 02.02.106	3	N267 02.02.106	3	N267 02.02.106	3
3	Drive shaft I	N267 02.02.108	1	N267 02.02.108	1	N267 02.02.108	1
4	Drive shaft II	N267 02.02.109	1	N267 02.02.109	1	N267 02.02.109	1
5	Shaft mounting	N267 02.02.110.1	1	N267 02.02.110.1	1	N267 02.02.110.1	1
6	Shaft connecting sleeve	N267 02.02.115	1	N267 02.02.115	1	N267 02.02.115	1
7	Bearing washer	N267 10.14.05	1	N267 10.14.05	1	N267 10.14.05	1
8	Sleeve housing	POD-ODL-000015	2	POD-ODL-000015	2	POD-ODL-000015	2
9	Coupling 6520-6-1/8 (RL31/C FOX6 1/8)	POD-HKR-000013-1	2	POD-HKR-000013-1	2	POD-HKR-000013-1	2
10	NK11 spheroidal chain wheel for the scraper system	POD-EOS-000398	4	POD-EOS-000398	4	POD-EOS-000398	4
11	Key 12 x 8 x 50 DIN 6885A	POD-ELZ-000077	5	POD-ELZ-000077	5	POD-ELZ-000077	5
12	Key 12 x 8 x 100 DIN 6885A	POD-ELZ-000078	1	POD-ELZ-000078	1	POD-ELZ-000078	1
13	Bolt 8 x 16 galv. 8.8 82105	23S8/16 8.8 82105 OC	4	23S8/16 8.8 82105 OC	4	23S8/16 8.8 82105 OC	4
14	Bolt 12 x 35 galv. 8.8 82105	23S12/35OC 8.8	3	23S12/35OC 8.8	3	23S12/35OC 8.8	3
15	Bolt 12 x 60 galv. 8.8 82101	23S12/60OC 8.8	4	23S12/60OC 8.8	4	23S12/60OC 8.8	4
16	Spring washer 12 galv. 82008 82008	23P12SP	7	23P12SP	7	23P12SP	7

**16. REAR SHAFT, COMPLETE**

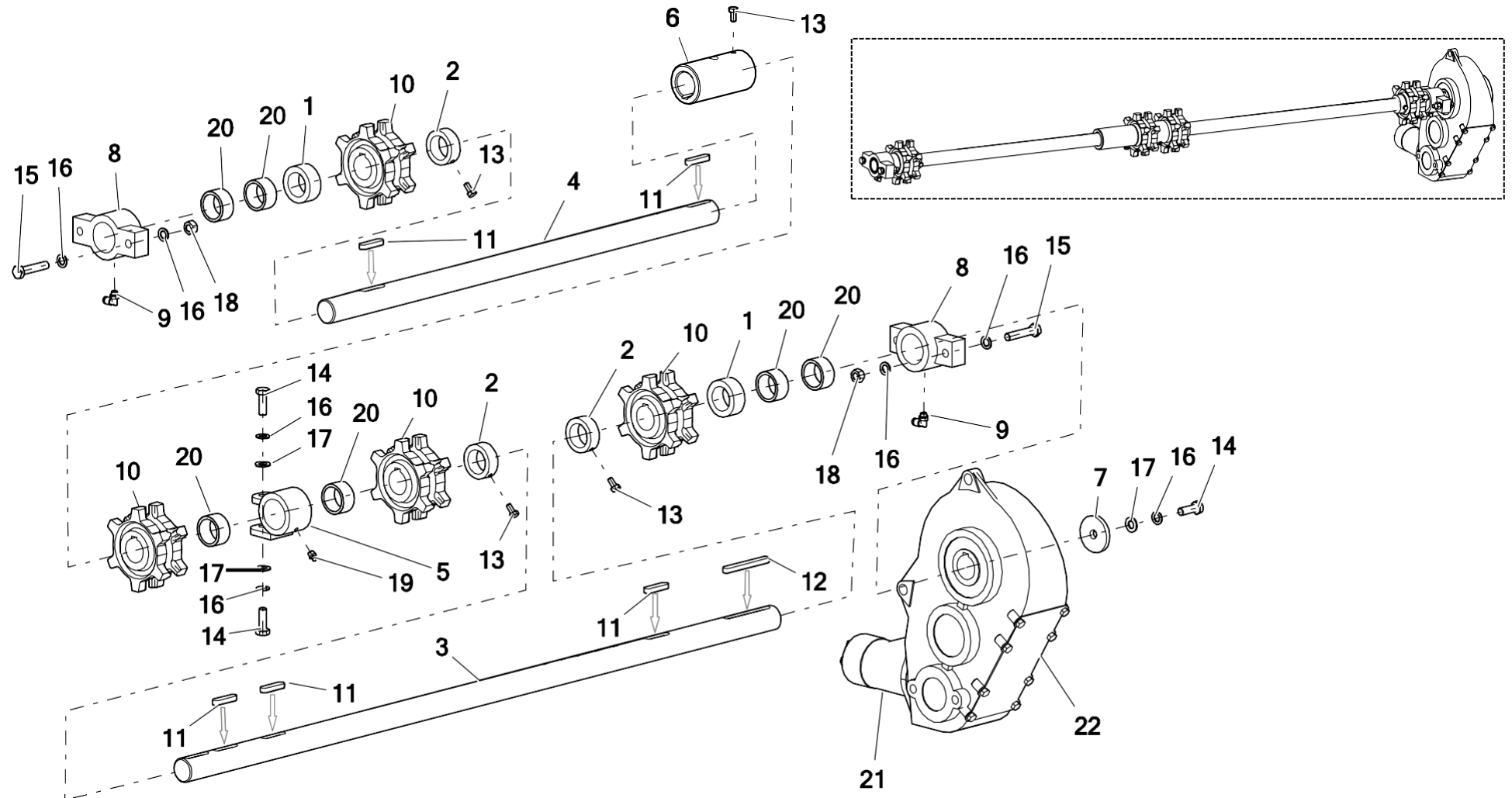

No.	Part or assembly name	Fig. or index No.					
		N267	Volume	N267/1	Volume	N267/2	Volume
17	Round washer 12 galv. 82005	23P12OC	3	23P12OC	3	23P12OC	3
18	Bolt M12 galv. 82144 5	23N12OC	4	23N12OC	4	23N12OC	4
19	Lubricating nipple M8 x 1.0 straight	23SM8	1	23SM8	1	23SM8	1
20	Self-lubricating sleeve 40H8/50R7x25	25T40/50/25	6	25T40/50/25	6	25T40/50/25	6
21	OMR 160 hydraulic motor (BMR)	POD-HSL-000003-1	1	POD-HSL-000003-1	1	POD-HSL-000003-1	1
22	Gearbox PRK-548-01.AAB.R- side	POD-WPS-000004- 1	1	POD-WPS-000004- 1	1	POD-WPS-000004- 1	1

# 17. DRIVE UNIT

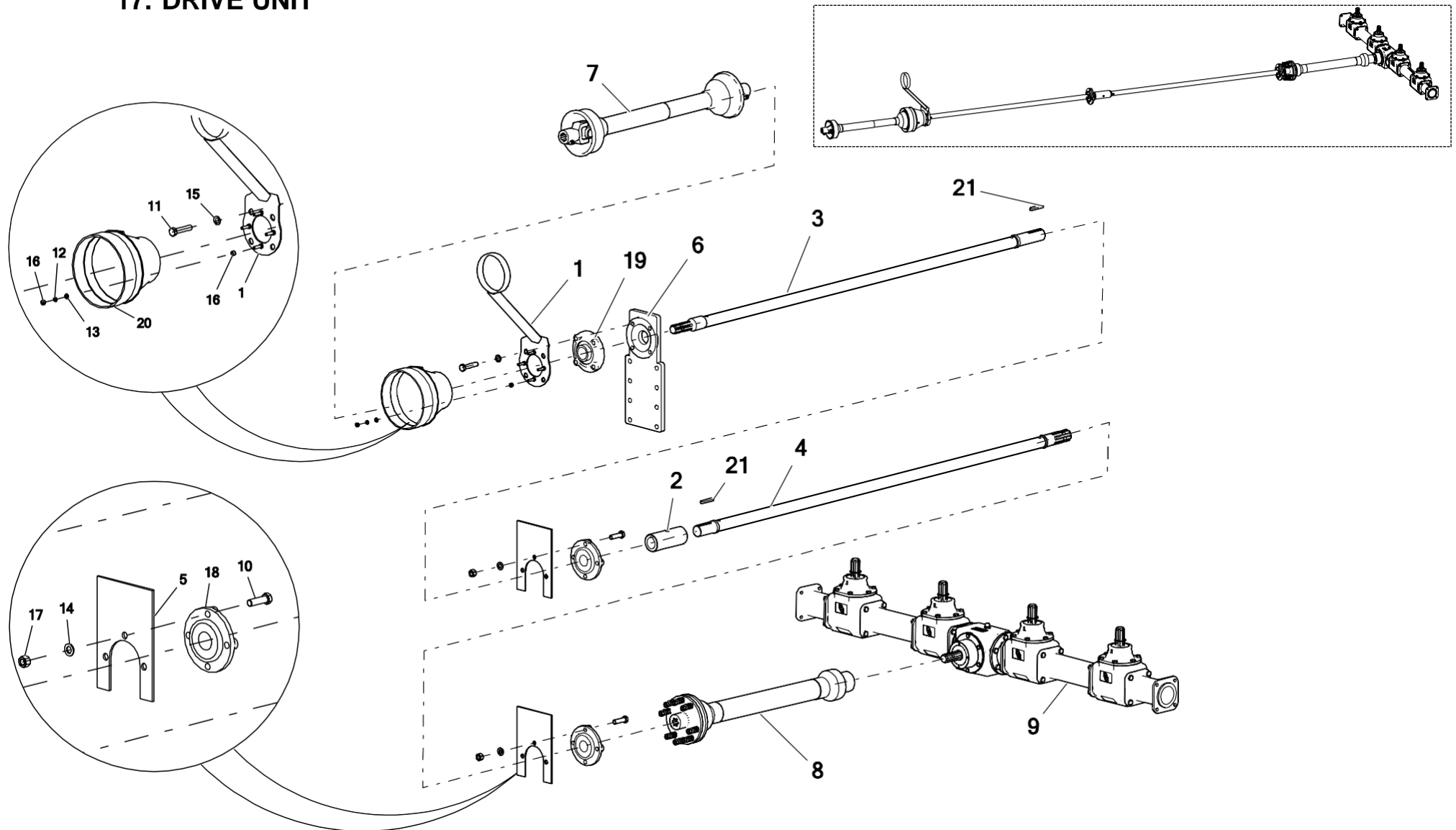

No.	Part or assembly name	Fig. or index No.					
		N267	Volume	N267/1	Volume	N267/2	Volume
1	Cable support	N267 02/11/2000	1	N267 02/11/2000	1	N267 02/11/2000	1
2	Coupling bushing	N267 02/04/2006	1	N267 02/04/2006	1	N267 02/04/2006	1
3	Shaft I	N267 02/04/2010	1	N267 02/04/2010	1	N267 02/04/2010	1
4	Shaft II	N267 02/04/2020	1	N267-1 02/04/2020	1	N267 02/04/2020	1
5	Shaft fixing	N267 02.01.22.1	2	N267 02.01.22.1	2	N267 02.01.22.1	2
6	Hitch holder	N267 02.03.101.2	1	N267 02.03.101.2	1	N267 02.03.101.2	1
7*	Articulated shaft (6R-602-6-HA-K6-1)	POD-WPS-000259	1	POD-WPS-000259	1	POD-WPS-000259	1
8	Articulated shaft with friction clutch (6T-602-3-BA-C644)	POD-WPS-000059	1	POD-WPS-000059	1	POD-WPS-000059	1
9	Gear PRK-051-01.1AAAA.R1	POD-WPS-000208	1	POD-WPS-000208	1	POD-WPS-000208	1
10	Bolt 16 x 55 galv. 8.8 82105	23S16/55OC	6	23S16/55OC	6	23S16/55OC	6
11	Bolt 16 x 75 galv. 8.8 82101	POD-ELZ-000050-1	4	POD-ELZ-000050-1	4	POD-ELZ-000050-1	4
12	Spring washer 8.2 galv. 82008	23P8SPOC	4	23P8SPOC	4	23P8SPOC	4
13	Round washer 8 galv. 82005	23P8OOC	4	23P8OOC	4	23P8OOC	4
14	Round washer 16 galv. 82005	23P16OOC	6	23P16OOC	6	23P16OOC	6
15	Spring washer 16.3 galv. 82008	23P16SP	4	23P16SP	4	23P16SP	4
16	Nut M8 galv. 82144	23N8OC	8	23N8OC	8	23N8OC	8
17	Nut M16 galv. 8.8 82144 5	23N16OC	6	23N16OC	6	23N16OC	6
18	Self-aligning bearing	UCFC209	2	UCFC209	2	UCFC209	2

# 18. DRIVE UNIT

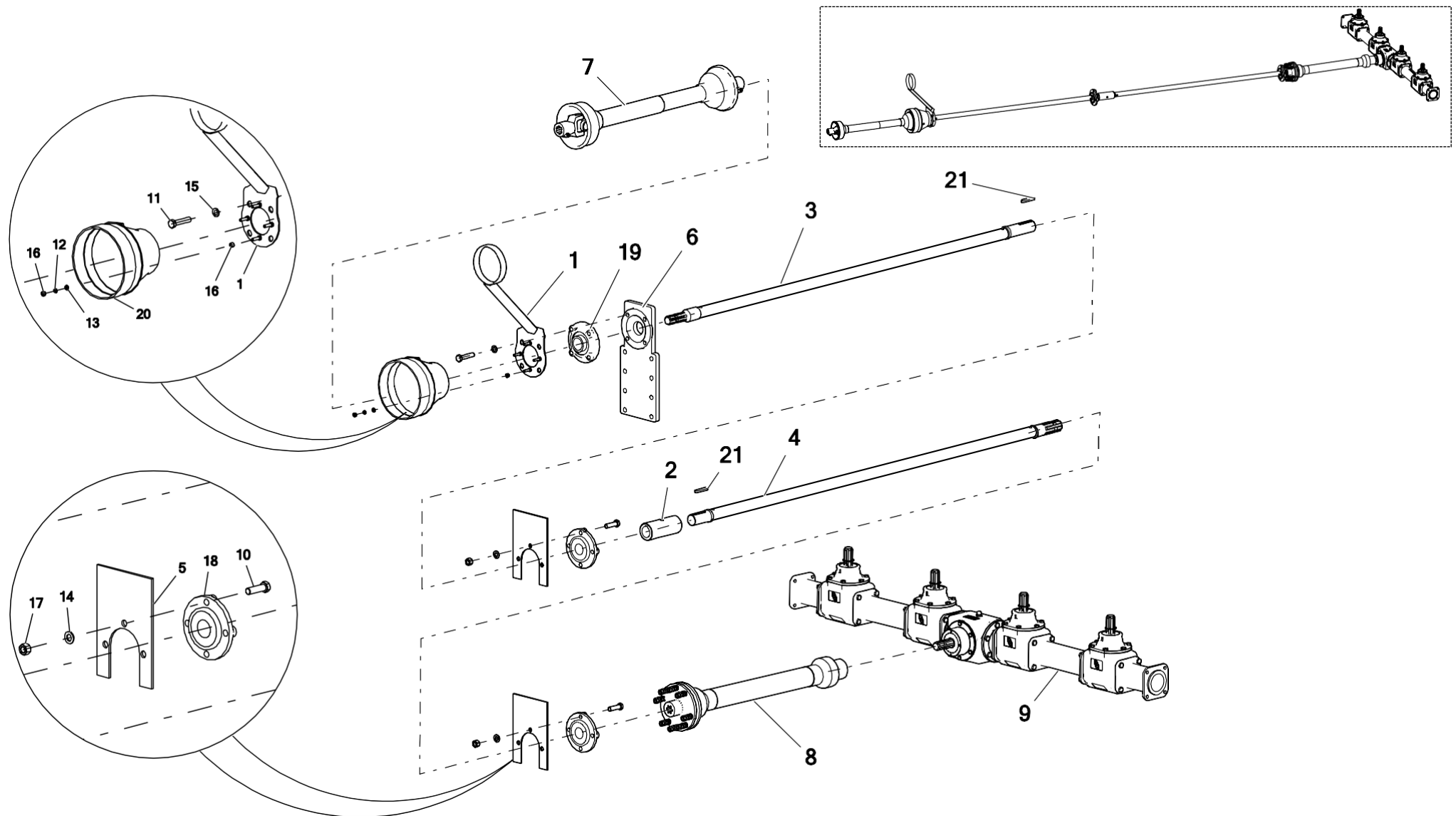



No.	Part or assembly name	Fig. or index No.					
		N267	Volume	N267/1	Volume	N267/2	Volume
19	Self-aligning bearing	UCFC210	1	UCFC210	1	UCFC210	1
20	Joint guard	25OW	1	25OW	1	25OW	1
21	Key 12 x 870 DIN 6885A	POD-ELZ-000433	2	POD-ELZ-000433	2	POD-ELZ-000433	2

**Key:**

**7\*** - The N267 02.03.400 hitch adapter worked with the POD-WPS-000032 articulated telescopic shaft or the 6R-602-2-BA-K601 articulated telescopic shaft, until February 2019. From February 2019 on, the N267 02.03.450 extended hitch adapter comes with the **POD-WS-000259 articulated telescopic shaft – 60960/602.K6-1/5NW 2000Nm L=860/1445 1.3/8 Z6** articulated shaft.

Until the end of February 2019, it was possible to use the POD-WPS-000141 wide-angle articulated telescopic shaft – the 60064/S602.K61-1/5NW 1860 Nm L-1210/1900 1.3/8 Z6 wide-angle articulated shaft. From February 2019 on, the N267 02.03.450 hitch adapter can work with the **POD-WPS-000260 telescopic articulated shaft – 60660/S602.K6-1/5NW 2000Nm L=860/1445 1.3/8 Z6 wide-angle articulated shaft**

## 19. SINGLE-SECTION HYDRAULIC SYSTEM (WITH A DISTRIBUTOR)

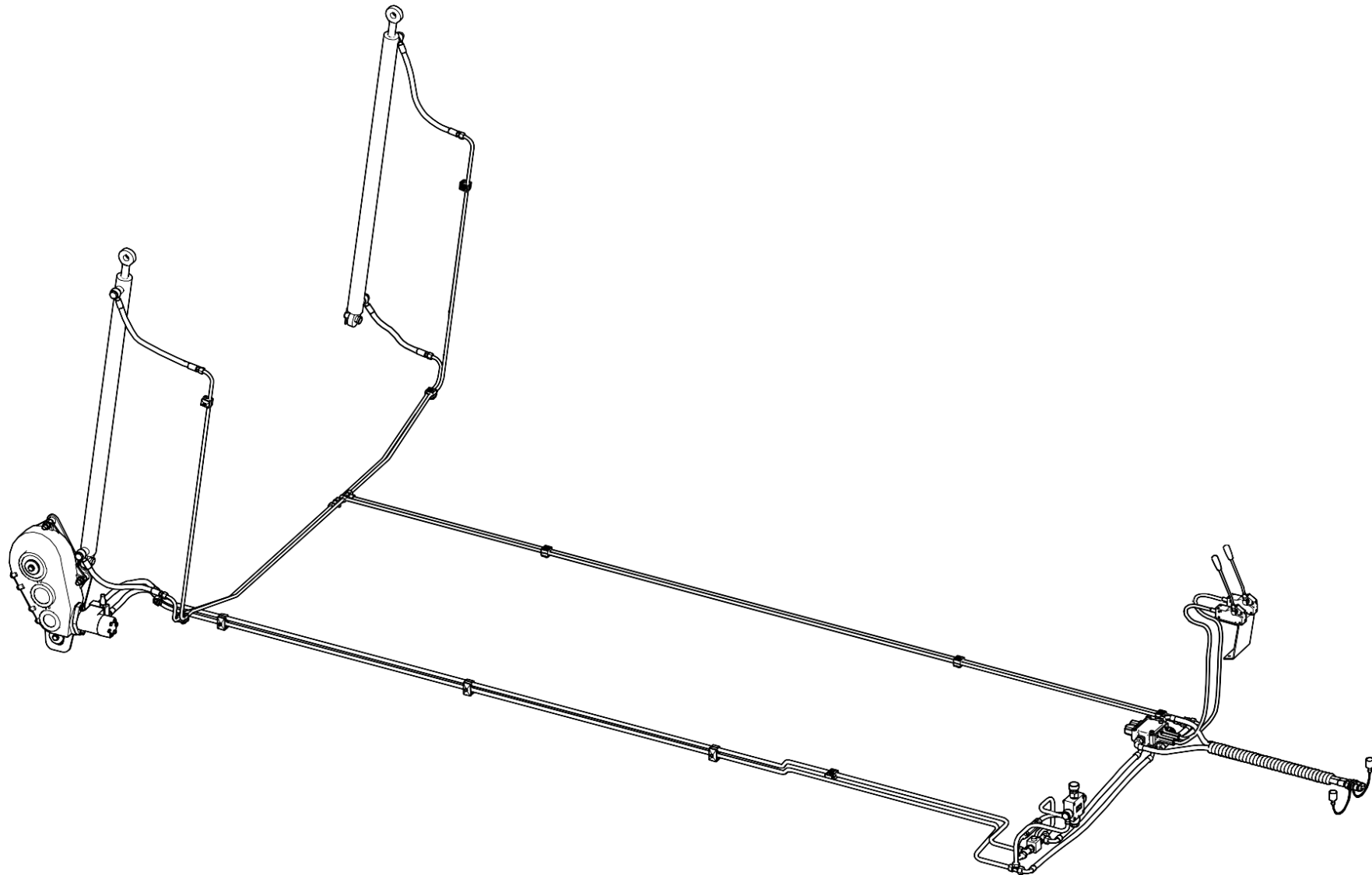

## 20. SINGLE-SECTION HYDRAULIC SYSTEM (WITH A DISTRIBUTOR) - conveyor section.

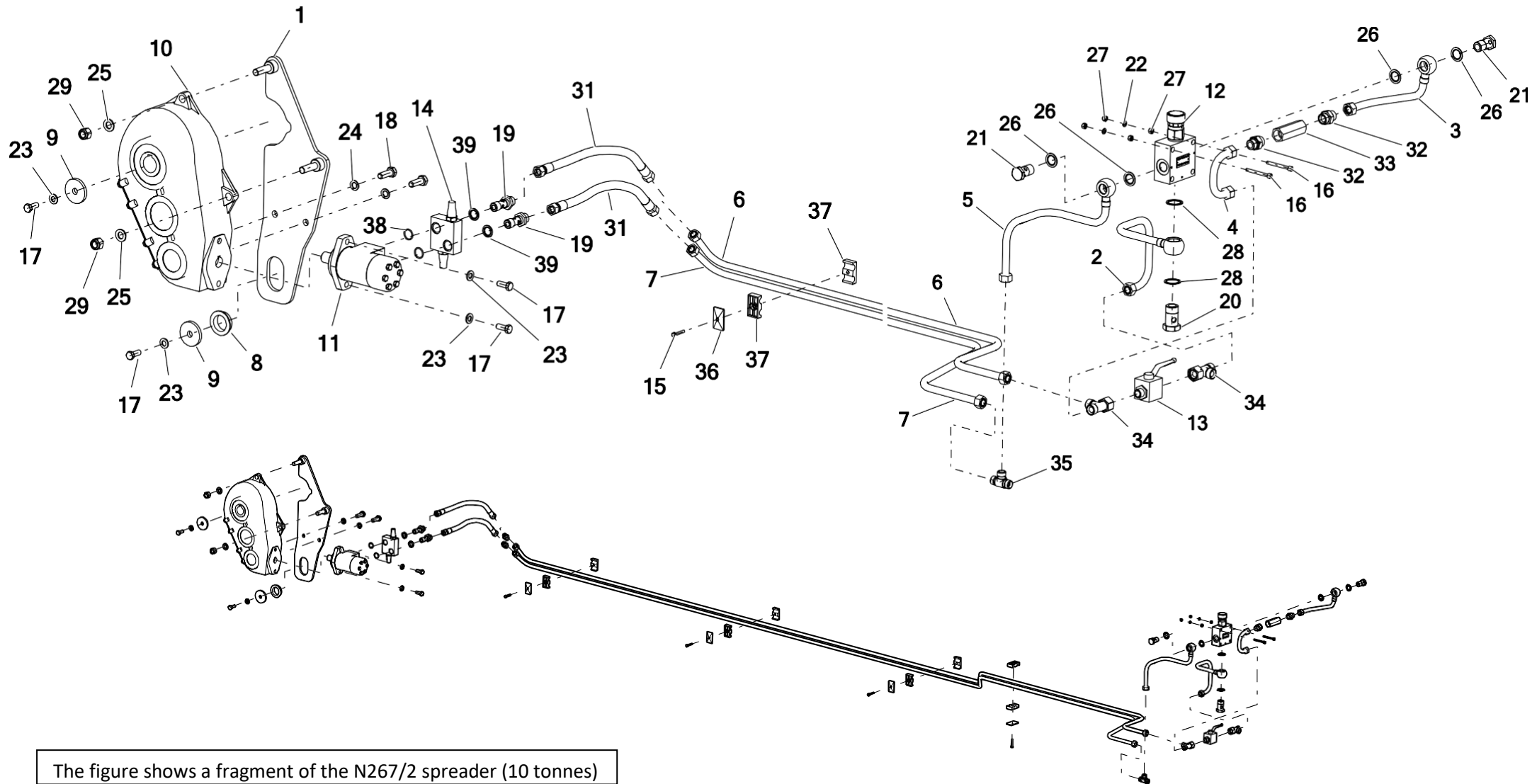

No.	Part or assembly name	Fig. or index No.					
		N267	Volume	N267/1	Volume	N267/2	Volume
1	Transmission fixing	N267 02.02.140	1	N267 02.02.140	1	N267 02.02.140	1
2	Steel hydraulic hose Ø15	N267 16.00.10	1	N267 16.00.10	1	N267 16.00.10	1
3	Steel hydraulic hose Ø15	N267 16.00.11	1	N267 16.00.11	1	N267 16.00.11	1
4	Steel hydraulic hose Ø15	N267 16.00.12	1	N267 16.00.12	1	N267 16.00.12	1
5	Steel hydraulic hose Ø15	N267 16.00.13	1	N267 16.00.13	1	N267 16.00.13	1
6	Steel hydraulic hose Ø15	N267 16.00.02	1	N267-1 16.00.02	1	N267-2 16.00.01	1
7	Steel hydraulic hose Ø15	N267 16.00.01	1	N267-1 16.00.01	1	N267-2 16.00.02	1
8	Gearbox mounting shoe	N267 03.00.09	1	N267 03.00.09	1	N267 03.00.09	1
9	Bearing washer	N272 10.14.05	2	N272 10.14.05	2	N272 10.14.05	2
10	Gearbox PRK-548-01.AAB.R - side	POD-WPS-000004- 1	1	POD-WPS- 000004- 1	1	POD-WPS- 000004- 1	1
11	OMR 160 hydraulic motor (BMR)	POD-HSL-000003-1	1	POD-HSL-000003-1	1	POD-HSL-000003- 1	1
12	Flow control valve VTC- UDUE10-22/50-4 - Ponar	POD-HZW-000113	1	POD-HZW-000113	1	POD-HZW-000113	1
13	Ball valve RS2 12L (with holes)	POD-HZW-000032	1	POD-HZW-000032	1	POD-HZW-000032	1
14	Locking valve VAU OM ½" WSC (60/60 bar)	POD-HZW-000128	1	POD-HZW-000128	1	POD-HZW-000128	1
15	Bolt 6 x 35 galv. 8.8 82105	23S6/35OC	4	23S6/35OC	4	23S6/35OC	4
16	Allen bolt 6 x 60 galv. 8.8 82302	POD-ELZ-000776	2	POD-ELZ-000776	2	POD-ELZ-000776	2

## 21. SINGLE-SECTION HYDRAULIC SYSTEM (WITH A DISTRIBUTOR) - conveyor section.

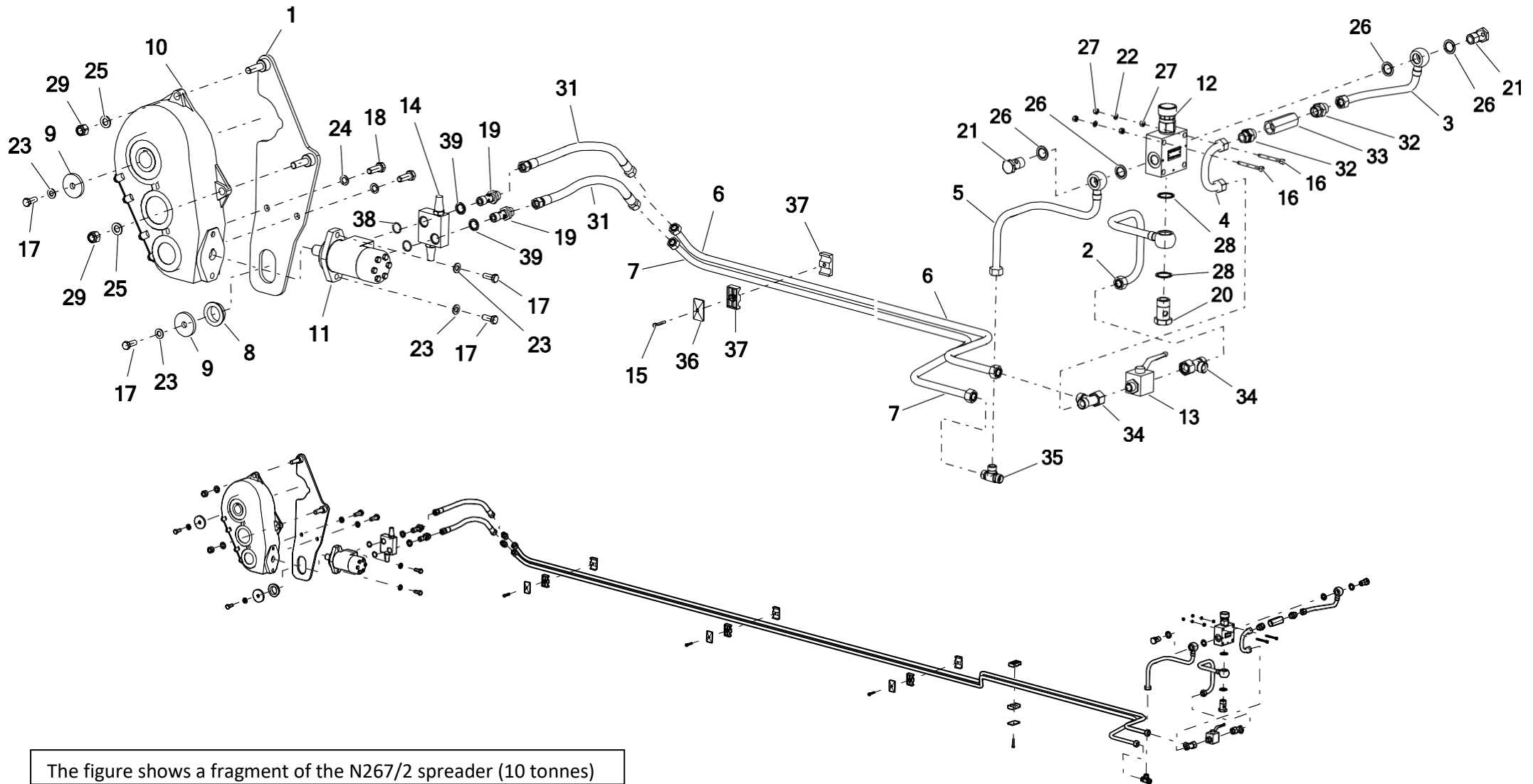

The figure shows a fragment of the N267/2 spreader (10 tonnes)

No.	Part or assembly name	Fig. or index No.					
		N267	Volume	N267/1	Volume	N267/2	Volume
17	Screw 12 x 30gal 8.8 82105 82105	23S12/30 galv. 8.8	4	23S12/30 galv. 8.8	4	23S12/30 galv. 8.8	4
18	Bolt 14 x 40 galv. 8.8 82105 82105	23S14/40 8.8	2	23S14/40 8.8	2	23S14/40 8.8	2
19	Hydraulic connecting bolt ½"/M22 x 1.5	POD-HZW-000099	2	POD-HZW-000099	2	POD-HZW-000099	2
20	Eye bolt ¾" 29 L42	POD-HKR-000019	1	POD-HKR-000019	1	POD-HKR-000019	1
21	Eye bolt ½" 20 L36	24SO1/2"	2	24SO1/2"	2	24SO1/2"	2
22	Spring washer 6.1 galv. 82008 82008	23P6SPOC	2	23P6SPOC	2	23P6SPOC	2
23	Round washer 12 galv. 82005	23P12OC	4	23P12OC	4	23P12OC	4
24	Spring washer 14.2 galv. 82008 82008	23P14SP	2	23P14SP	2	23P14SP	2
25	Round washer 16 galv. 82005 82005	23P16OOC	2	23P16OOC	2	23P16OOC	2
26	Metal & rubber washer PPM22 30 x 22	24UPPM22	4	24UPPM22	4	24UPPM22	4
27	Nut M6 galv. 82144 5	23N6OC	4	23N6OC	4	23N6OC	4
28	Metal-rubber washer PPM ¾" (M27)	POD-HPZ-000052	2	POD-HPZ-000052	2	POD-HPZ-000052	2
29	Self-locking nut M16 galv. 82175 8 82175 8	23NS16OC	2	23NS16OC	2	23NS16OC	2
30	Flexible hydraulic hose	A90A/233/13L-3000	1	A90A/233/13L-3000	1	A90A/233/13L-3000	1
31	Flexible hydraulic hose	AB/213/13L-500	2	AB/213/13L-500	2	AB/213/13L-500	2
32	Straight connector ½ edx 22-1.5	24K1/2 22	2	24K1/2 22	2	24K1/2 22	2

## 22. SINGLE-SECTION HYDRAULIC SYSTEM (WITH A DISTRIBUTOR) - conveyor section.

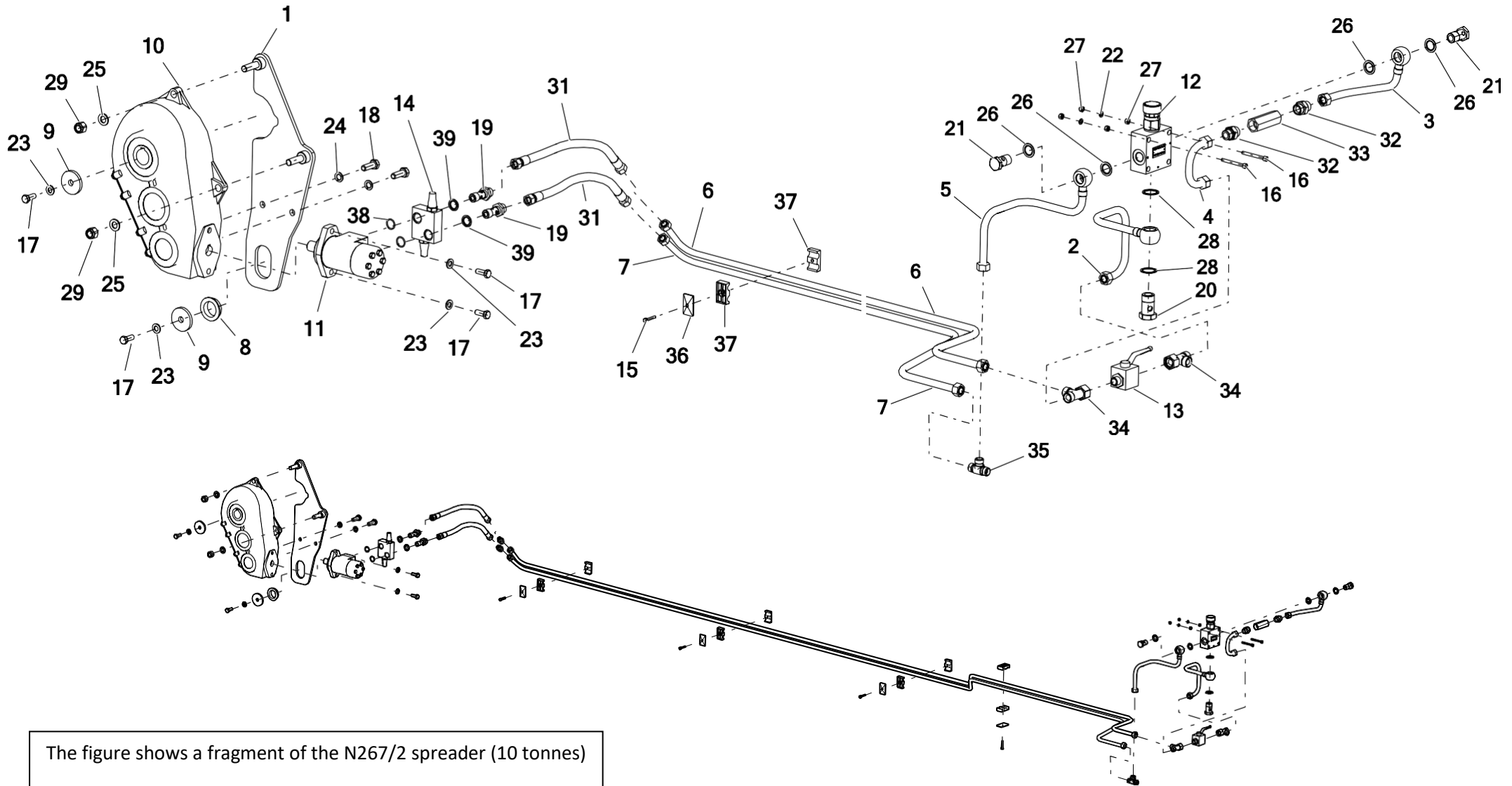

The figure shows a fragment of the N267/2 spreader (10 tonnes)

No.	Part or assembly name	Fig. or index No.					
		N267	Volume	N267/1	Volume	N267/2	Volume
33	Non-return valve	POD-HZW-000014-1	1	POD-HZW-000014- 1	1	POD-HZW-000014- 1	1
34	Non-symmetrical T-pipe connector 22 x 22 x 22-1.5 15L side nut	POD-HKR-000007-1	2	POD-HKR-000007-1	2	POD-HKR-000007-1	2
35	T-coupling 18 x 18 x 18 12L	24KT18/18/18	1	24KT18/18/18	1	24KT18/18/18	1
36	Handle HBK 15 x 2 - cover	POD-HPZ-000085	4	POD-HPZ-000085	4	POD-HPZ-000085	4
37	Handle HBK 15 x 2 - plastic	POD-HPZ-000085	8	POD-HPZ-000085	8	POD-HPZ-000085	8
38	Rubber washer Ø27	POD-HZW-000099	2	POD-HZW-000099	2	POD-HZW-000099	2
39	Seal ring PPM22 30 x 22	24UPPM22	2	24UPPM22	2	24UPPM22	2

**Key:**

The following items are also included as: **Valve, complete - POD-HZW-000099**

No. 14 - Locking valve VAU OM ½" WSC (60/60 bar) – index No. POD-HZW-000128

No. 19 - Hydraulic connecting bolt ½"/M22 x 1.5 – index No. POD-HZW-000099 No.

42 - Rubber washer Ø27 - index No. POD-HZW-000099

No. 43 - Sealing ring PPM22 30 x 22 - index No. 24UPPM22



### 23. SINGLE-SECTION HYDRAULIC SYSTEM (WITH A DISTRIBUTOR) - gate valve section.

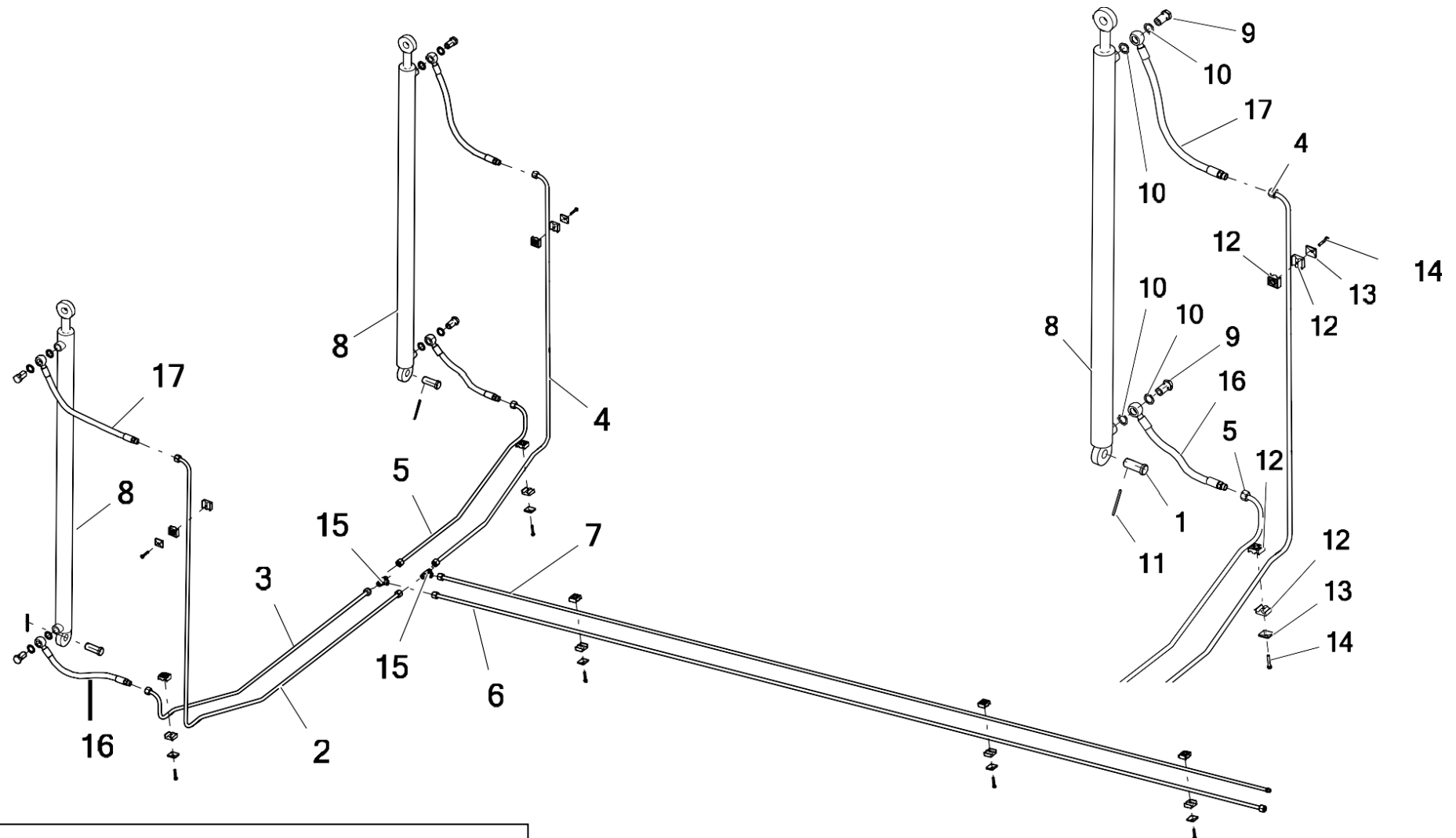

The figure shows a fragment of the N267/2 spreader (10 tonnes)

No.	Part or assembly name	Fig. or index No.					
		N267	Volume	N267/1	Volume	N267/2	Volume
1	Actuator bottom pin	N267 00.00.33	2	N267 00.00.33	2	N267 00.00.33	2
2	Steel hydraulic hose Ø12	N267 16.00.03	1	N267-1 16.00.03	1	N267 16.00.03	1
3	Steel hydraulic hose Ø12	N267 16.00.04	1	N267 16.00.04	1	N267 16.00.04	1
4	Steel hydraulic hose Ø12	N267 16.00.05	1	N267-1 16.00.05	1	N267 16.00.05	1
5	Steel hydraulic hose Ø12	N267 16.00.06	1	N267 16.00.06	1	N267 16.00.06	1
6	Steel hydraulic hose Ø12	N267 16.00.07	1	N267-1 16.00.07	1	N267 16.00.07	1
7	Steel hydraulic hose Ø12	N267 16.00.08	1	N267-1 16.00.08	1	N267 16.00.08	1
8	Cylinder USJ2F-50/28/1200 L-1377	POD-HSL-000027-1	2	-----	---	POD-HSL-000027- 1	2
	Cylinder USJ2F-50- 28-1000 L-1232	-----	---	POD-HSL-000026-1	2	-----	---
9	Eye bolt M22 x 1.5 22 L38	POD-HPZ-000009-1	4	POD-HPZ-000009-1	4	POD-HPZ-000009- 1	4
10	Copper washer Ø22 x 28 x 1.5	24U22	8	24U22	8	24U22	8
11	Cotter pin 5 x 63 galv.	23Z5/63	2	23Z5/63	2	23Z5/63	2
12	Handle HBK 12 x 2 - plastic	POD-HPZ-000010-1	14	POD-HPZ-000010-1	14	POD-HPZ-000010- 1	14
13	Handle HBK 12 x 2 - cover	POD-HPZ-000010-1	7	POD-HPZ-000010-1	7	POD-HPZ-000010- 1	7
14	Bolt 6 x 35 galv. 8.8 82105	23S6/35OC	7	23S6/35OC	7	23S6/35OC	7
15	T-coupling 18 x 18 x 18 12L	24KT18/18/18	2	24KT18/18/18	2	24KT18/18/18	2

## 24. SINGLE-SECTION HYDRAULIC SYSTEM (WITH A DISTRIBUTOR) - gate valve section.

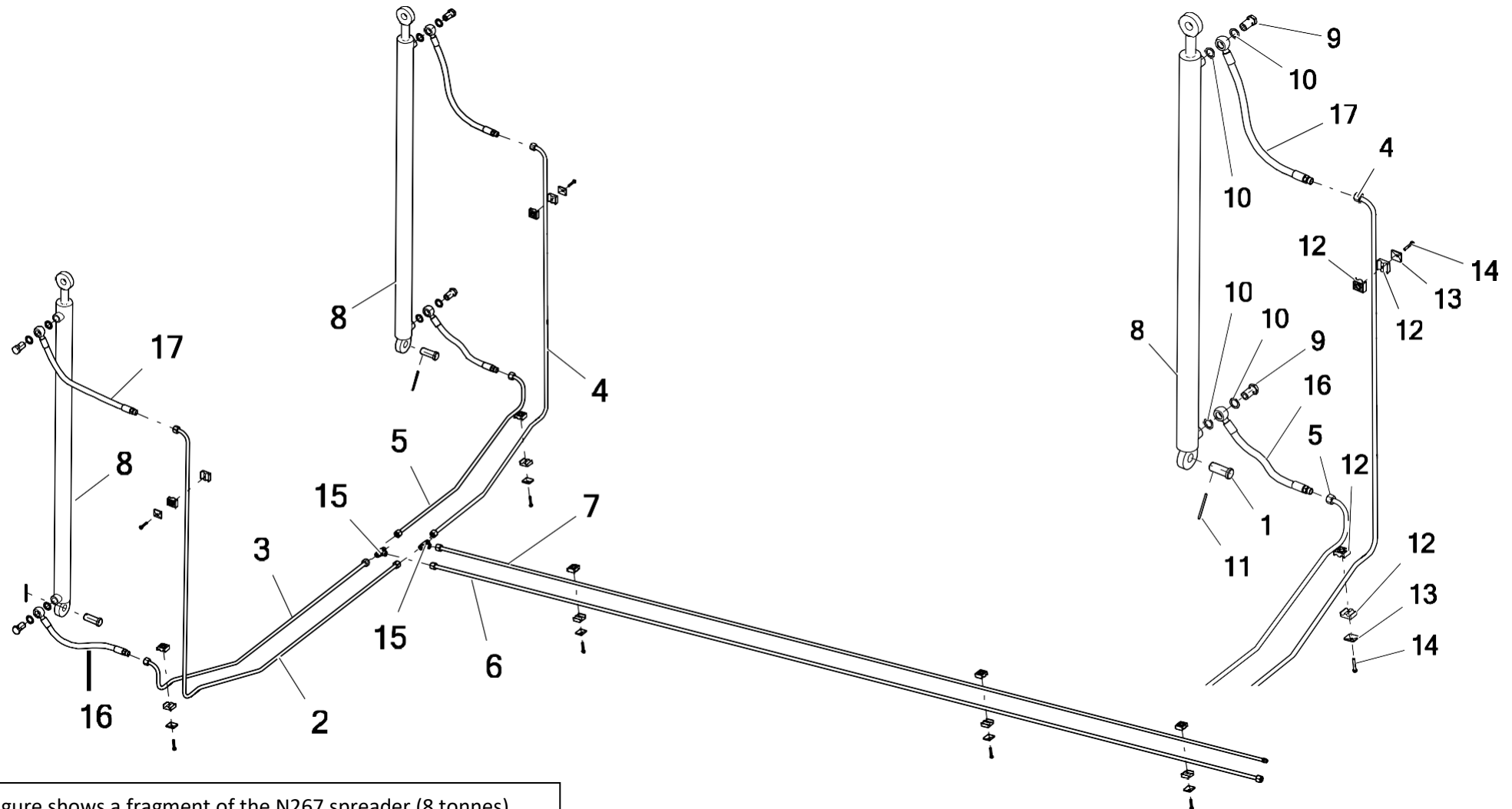

The figure shows a fragment of the N267 spreader (8 tonnes)

No.	Part or assembly name	Fig. or index No.					
		N267	Volume	N267/1	Volume	N267/2	Volume
16	Flexible hydraulic hose	RNMB/2 1/10 L-400	2	RNMB/2 1/10 L-400	2	RNMB/2 1/10 L-400	2
17	Flexible hydraulic hose	RNMB/2 1/10 L-500	2	RNMB/2 1/10 L-500	2	RNMB/2 1/10 L-500	2

**25. SINGLE-SECTION HYDRAULIC SYSTEM (WITH A DISTRIBUTOR) - control section.**

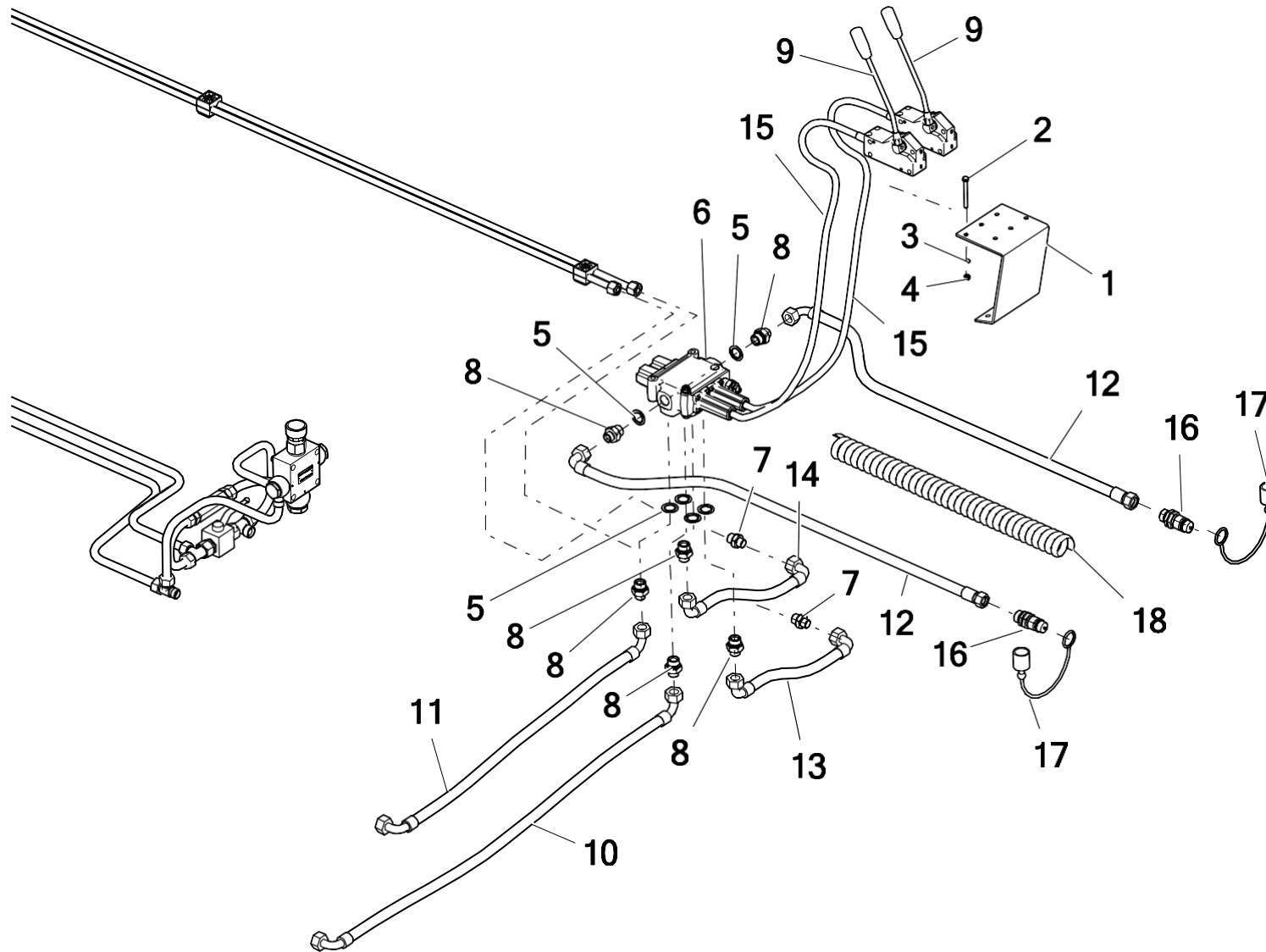

No.	Part or assembly name	Fig. or index No.					
		N267	Volume	N267/1	Volume	N267/2	Volume
1	Distributor lever support	N267 17.00.01	1	N267 17.00.01	1	N267 17.00.01	1
2	Bolt 6 x 60gal 8.8 82101 82101	23S6/60OC 8.8	4	23S6/60OC 8.8	4	23S6/60OC 8.8	4
3	Round washer 6 galv. 82005 82005	23POOC	4	23POOC	4	23POOC	4
4	Self-locking nut M6 galv. 82175 8 82175 8	23NS6OC	4	23NS6OC	4	23NS6OC	4
5	Metal & rubber washer PPM22 30 x 22	2UPPM22	6	2UPPM22	6	2UPPM22	6
6	MD2 rope distributor Q45"S"	24RMD2 70/320	1	24RMD2 70/320	1	24RMD2 70/320	1
7	Straight connector 18 x 1.5/16 x 1.5	POD-HKR-000076	2	POD-HKR-000076	2	POD-HKR-000076	2
8	Straight connector ½ edx. 18-1.5	24KP1/2 18	6	24KP1/2 18	6	24KP1/2 18	6
9	Rope controller lever	24DZS	2	24DZS	2	24DZS	2
10	Flexible hydraulic hose	A90A90/233/13 950	1	A90A90/233/13 950	1	A90A90/233/13 950	1
11	Flexible hydraulic hose	A90A90/233/13 700	1	A90A90/233/13 700	1	A90A90/233/13 700	1
12	Flexible hydraulic hose	24PRNMA/124/10	2	24PRNMA/124/10	2	24PRNMA/124/10	2
13	Flexible hydraulic hose	A9090/211/10 270	1	A9090/211/10 270	1	A9090/211/10 270	1
14	Flexible hydraulic hose	A9090/211/10 300	1	A9090/211/10 300	1	A9090/211/10 300	1
15	Control rope L-2800	24LS2,8M	2	24LS2,8M	2	24LS2,8M	2

## 26. SINGLE-SECTION HYDRAULIC SYSTEM (WITH A DISTRIBUTOR) - control section.

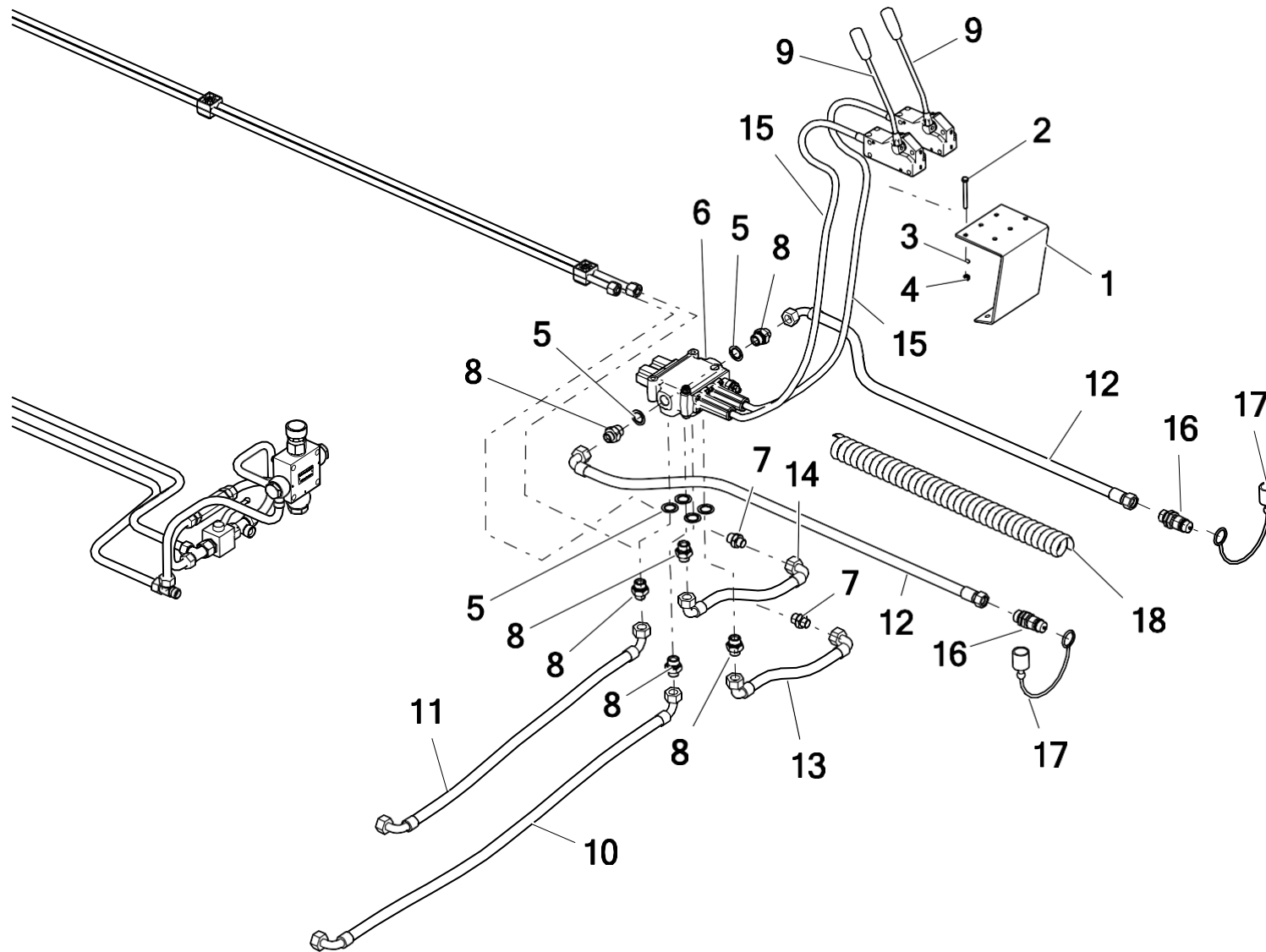

No.	Part or assembly name	Fig. or index No.					
		N267	Volume	N267/1	Volume	N267/2	Volume
16	Plug valve EURO 13 M22 x 1.5	24ZWE13	2	24ZWE13	2	24ZWE13	2
17	Plug valve cover	24ZWNE13	2	24ZWNE13	2	24ZWNE13	2
18	Spiral guard HG-32/inside diameter 28/ (25-32) L-3500	POD-HPZ-000042-1	1	POD-HPZ-000042-1	1	POD-HPZ-000042-1	1

**Key:**

**N267 spreader (8 tonnes);** the following items are also included as: **22-1 set 8T spreader - POD-HPR-000263**

Item 20, No. 2 - Hydraulic hose Steel Ø15 - N267 16.00.10 - 1 piece

No. 3 - Hydraulic hose Steel Ø15 - N267 16.00.11 - 1 piece

No. 4 - Hydraulic hose Steel Ø15 - N267 16.00.12 - 1 piece

No. 5 - Hydraulic hose Steel Ø15 - N267 16.00.13 - 1 piece

No. 6 - Hydraulic hose Steel Ø15 - N267 16.00.02 - 1 piece

No. 7 - Hydraulic hose Steel Ø15 - N267 16.00.01 - 1 piece

Item 21, No. 30 - Hydraulic hose Flexible A90A/233/13 L-3000 – 2 pieces

Item 23, No. 2 - Hydraulic hose Steel Ø15 - N267 16.00.03 - 1 piece

No. 3 - Hydraulic hose Steel Ø15 - N267 16.00.04 - 1 piece

No. 4 - Hydraulic hose Steel Ø15 - N267 16.00.05 - 1 piece

No. 5 - Hydraulic hose Steel Ø15 - N267 16.00.06 - 1 piece

No. 6 - Hydraulic hose Steel Ø15 - N267 16.00.07 - 1 piece

No. 7 - Hydraulic hose Steel Ø15 - N267 16.00.08 - 1 piece

No. 31 - Hydraulic hose Flexible AB/213/13 L-500 – 2 pieces

Item 24, No. 16 – Hydraulic hose Flexible RNMB/2\_1/10 L-400 (M22 mesh) - 2 pieces

No. 17 – Hydraulic hose Flexible RNMB/2\_1/10 L-500 (M22 mesh) - 2 pieces

Item 25, No. 30 - Hydraulic hose Flexible A90/233/13 L-950, the ends turned to the right by 90 degrees – 1 piece

No. 11 - Hydraulic hose Flexible A90A90/233/13 L-700, the ends turned to the right by 90 degrees – 1 piece

No. 13 - Hydraulic hose Flexible A9090/211/10 L-270, the ends turned to the left by 90 degrees – 1 piece

No. 14 - Hydraulic hose Flexible A9090/211/10 L-300, the ends turned to the left by 90 degrees – 1 piece



**N267/1 spreader (6 tonnes);** the following items are also included as: **21-1 set 8T spreader - POD-HPR-000262**

Item 20, No. 2 - Hydraulic hose Steel Ø15 - N267 16.00.10 - 1 piece

No. 3 - Hydraulic hose Steel Ø15 - N267 16.00.11 - 1 piece

No. 4 - Hydraulic hose Steel Ø15 - N267 16.00.12 - 1 piece

No. 5 - Hydraulic hose Steel Ø15 - N267 16.00.13 - 1 piece

No. 6 - Hydraulic hose Steel Ø15 - N267-1 16.00.02 - 1 piece

No. 7 - Hydraulic hose Steel Ø15 - N267-1 16.00.01 - 1 piece

Item 21, No. 30 - Hydraulic hose Flexible A90A/233/13 L-3000 – 2 pieces

No. 31 - Hydraulic hose Flexible RNMB/213/13L - 500 - 2 pieces

Item 23, No. 2 - Hydraulic hose Steel Ø15 - N267-1 16.00.03 - 1 piece

No. 3 - Hydraulic hose Steel Ø15 - N267 16.00.04 - 1 piece

No. 4 - Hydraulic hose Steel Ø15 - N267-1 16.00.05 - 1 piece

No. 5 - Hydraulic hose Steel Ø15 - N267 16.00.06 - 1 piece

No. 6 - Hydraulic hose Steel Ø15 - N267-1 16.00.07 - 1 piece

No. 7 - Hydraulic hose Steel Ø15 - N267-1 16.00.08 - 1 piece

Item 24, No. 16 – Hydraulic hose Flexible RNMB/2\_1/10 L-400 (M22 mesh) - 2 pieces

No. 17 – Hydraulic hose Flexible RNMB/2\_1/10 L-500 (M22 mesh) - 2 pieces

Item 25, No. 30 - Hydraulic hose Flexible A90/233/13 L-950, the ends turned to the right by 90 degrees – 1 piece

No. 11 - Hydraulic hose Flexible A90A90/233/13 L-700, the ends turned to the right by 90 degrees – 1 piece

No. 13 - Hydraulic hose Flexible A9090/211/10 L-270, the ends turned to the left by 90 degrees – 1 piece

No. 14 - Hydraulic hose Flexible A9090/211/10 L-300, the ends turned to the left by 90 degrees – 1 piece

**N267/2 spreader (10 tonnes);** the following items are also included as: **22-5 set 10T spreader - POD-HPR-000851**

Item 20, No. 2 - Hydraulic hose Steel Ø15 - N267 16.00.10 - 1 piece

No. 3 - Hydraulic hose Steel Ø15 - N267 16.00.11 - 1 piece

No. 4 - Hydraulic hose Steel Ø15 - N267 16.00.12 - 1 piece

No. 5 - Hydraulic hose Steel Ø15 - N267 16.00.13 - 1 piece

No. 6 - Hydraulic hose Steel Ø15 - N267-2 16.00.01 - 1 piece

No. 7 - Hydraulic hose Steel Ø15 - N267-2 16.00.02 - 1 piece

- Item 21, No. 30 - Hydraulic hose Flexible A90A/233/13 L-3000 – 2 pieces
  - No. 31 - Hydraulic hose Flexible RNMB/213/13L - 500 - 2 pieces
- Item 23, No. 2 - Hydraulic hose Steel Ø15 - N267 16.00.03 - 1 piece
  - No. 3 - Hydraulic hose Steel Ø15 - N267 16.00.04 - 1 piece
  - No. 4 - Hydraulic hose Steel Ø15 - N267 16.00.05 - 1 piece
  - No. 5 - Hydraulic hose Steel Ø15 - N267 16.00.06 - 1 piece
  - No. 6 - Hydraulic hose Steel Ø15 - N267 16.00.07 - 1 piece
  - No. 7 - Hydraulic hose Steel Ø15 - N267 16.00.08 - 1 piece
- Item 24, No. 16 – Hydraulic hose Flexible RNMB/2\_1/10 L-400 (M22 mesh) - 2 pieces
  - No. 17 – Hydraulic hose Flexible RNMB/2\_1/10 L-500 (M22 mesh) - 2 pieces
- Item 25, No. 30 - Hydraulic hose Flexible A90/233/13 L-950, the ends turned to the right by 90 degrees – 1 piece
  - No. 11 - Hydraulic hose Flexible A90A90/233/13 L-700, the ends turned to the right by 90 degrees – 1 piece
  - No. 13 - Hydraulic hose Flexible A9090/211/10 L-270, the ends turned to the left by 90 degrees – 1 piece
  - No. 14 - Hydraulic hose Flexible A9090/211/10 L-300, the ends turned to the left by 90 degrees – 1 piece

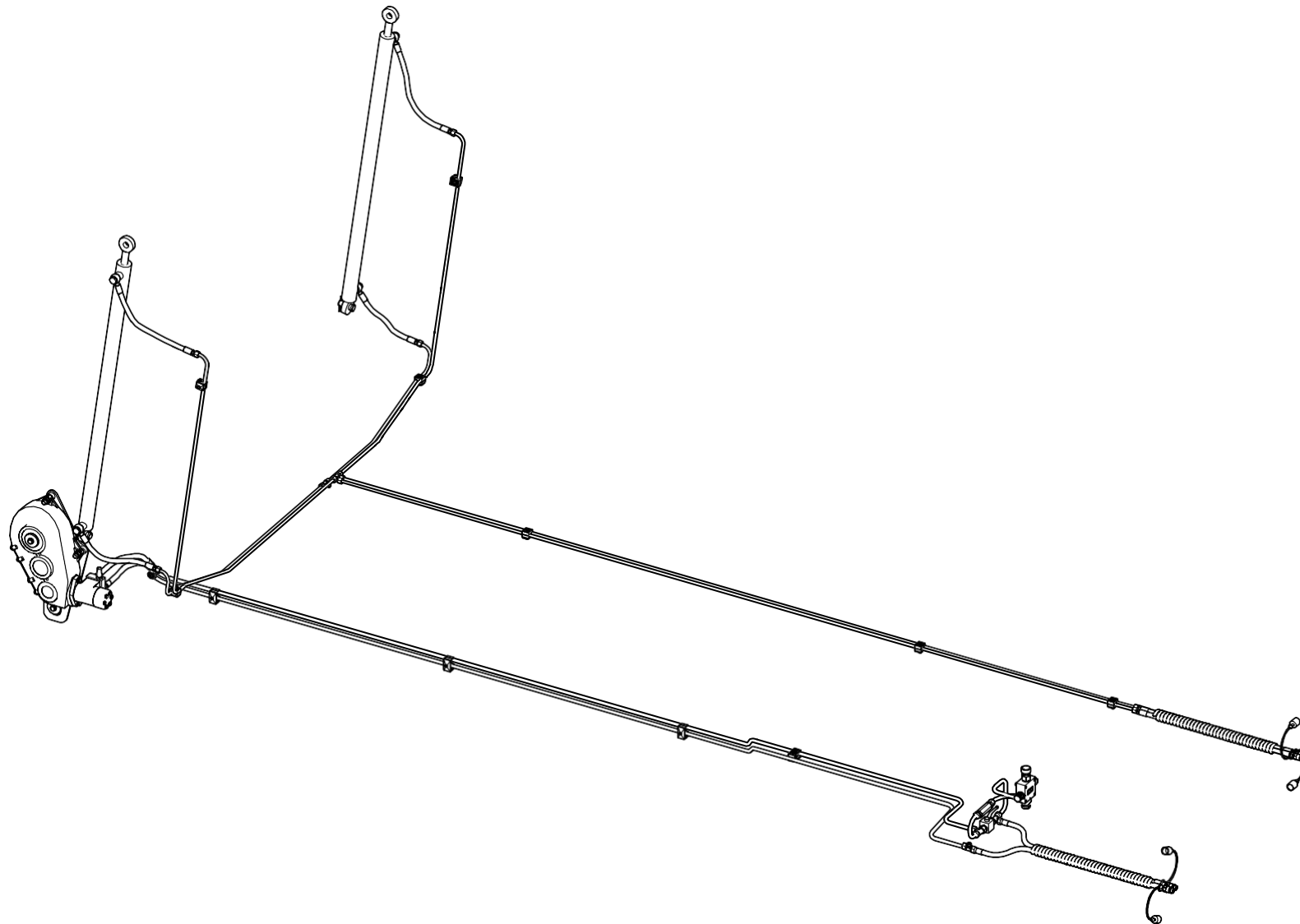
**27. TWO-SECTION HYDRAULIC SYSTEM**

## 28. TWO-SECTION HYDRAULIC SYSTEM - conveyor section.

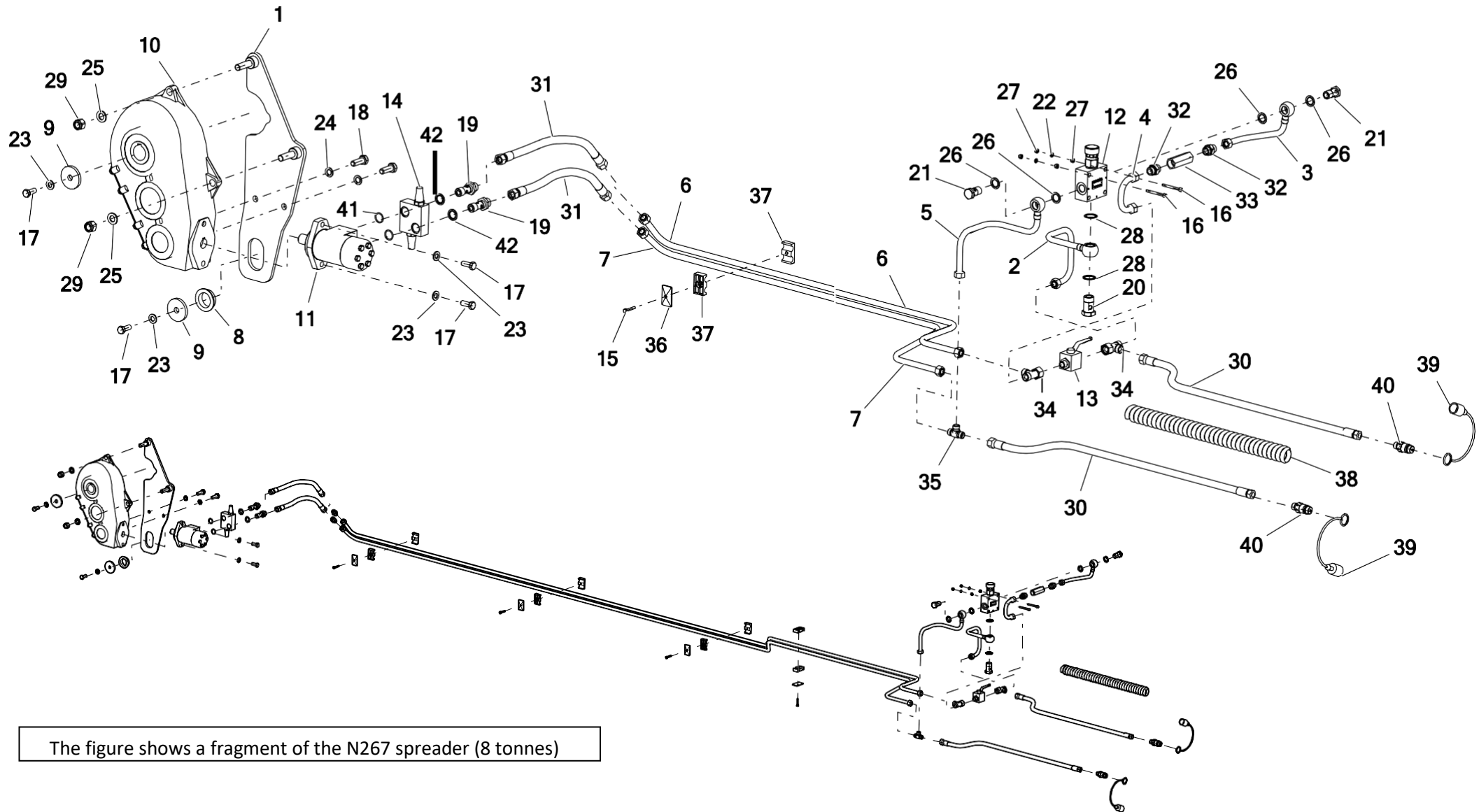

No.	Part or assembly name	Fig. or index No.					
		N267	Volume	N267/1	Volume	N267/2	Volume
1	Transmission fixing	N267 02.02.140	1	N267 02.02.140	1	N267 02.02.140	1
2	Steel hydraulic hose Ø15	N267 16.00.10	1	N267 16.00.10	1	N267 16.00.10	1
3	Steel hydraulic hose Ø15	N267 16.00.11	1	N267 16.00.11	1	N267 16.00.11	1
4	Steel hydraulic hose Ø15	N267 16.00.12	1	N267 16.00.12	1	N267 16.00.12	1
5	Steel hydraulic hose Ø15	N267 16.00.13	1	N267 16.00.13	1	N267 16.00.13	1
6	Steel hydraulic hose Ø15	N267 16.00.02	1	N267-1 16.00.02	1	N267-2 16.00.01	1
7	Steel hydraulic hose Ø15	N267 16.00.01	1	N267-1 16.00.01	1	N267-2 16.00.02	1
8	Gearbox mounting shoe	N267 03.00.09	1	N267 03.00.09	1	N267 03.00.09	1
9	Bearing washer	N272 10.14.05	2	N272 10.14.05	2	N272 10.14.05	2
10	Gearbox PRK-548-01.AAB.R - side	POD-WPS-000004- 1	1	POD-WPS- 000004- 1	1	POD-WPS- 000004- 1	1
11	OMR 160 (BMR) hydraulic motor	POD-HSL-000003-1	1	POD-HSL-000003-1	1	POD-HSL- 000003-1	1
12	Flow control valve VTC- UDUE10-22/50-4 - Ponar	POD-HZW-000113	1	POD-HZW-000113	1	POD-HZW- 000113	1
13	Ball valve RS2 12L (with holes)	POD-HZW-000032	1	POD-HZW-000032	1	POD-HZW- 000032	1
14	Locking valve VAU OM ½" WSC (60/60 bar)	POD-HZW-000128	1	POD-HZW-000128	1	POD-HZW- 000128	1
15	Bolt 6 x 35 galv. 8.8 82105	23S6/35OC	4	23S6/35OC	4	23S6/35OC	4
16	Allen bolt 6 x 60 galv. 8.8 82302	POD-ELZ-000776	2	POD-ELZ-000776	2	POD-ELZ-000776	2

## 29. TWO-SECTION HYDRAULIC SYSTEM - conveyor section.

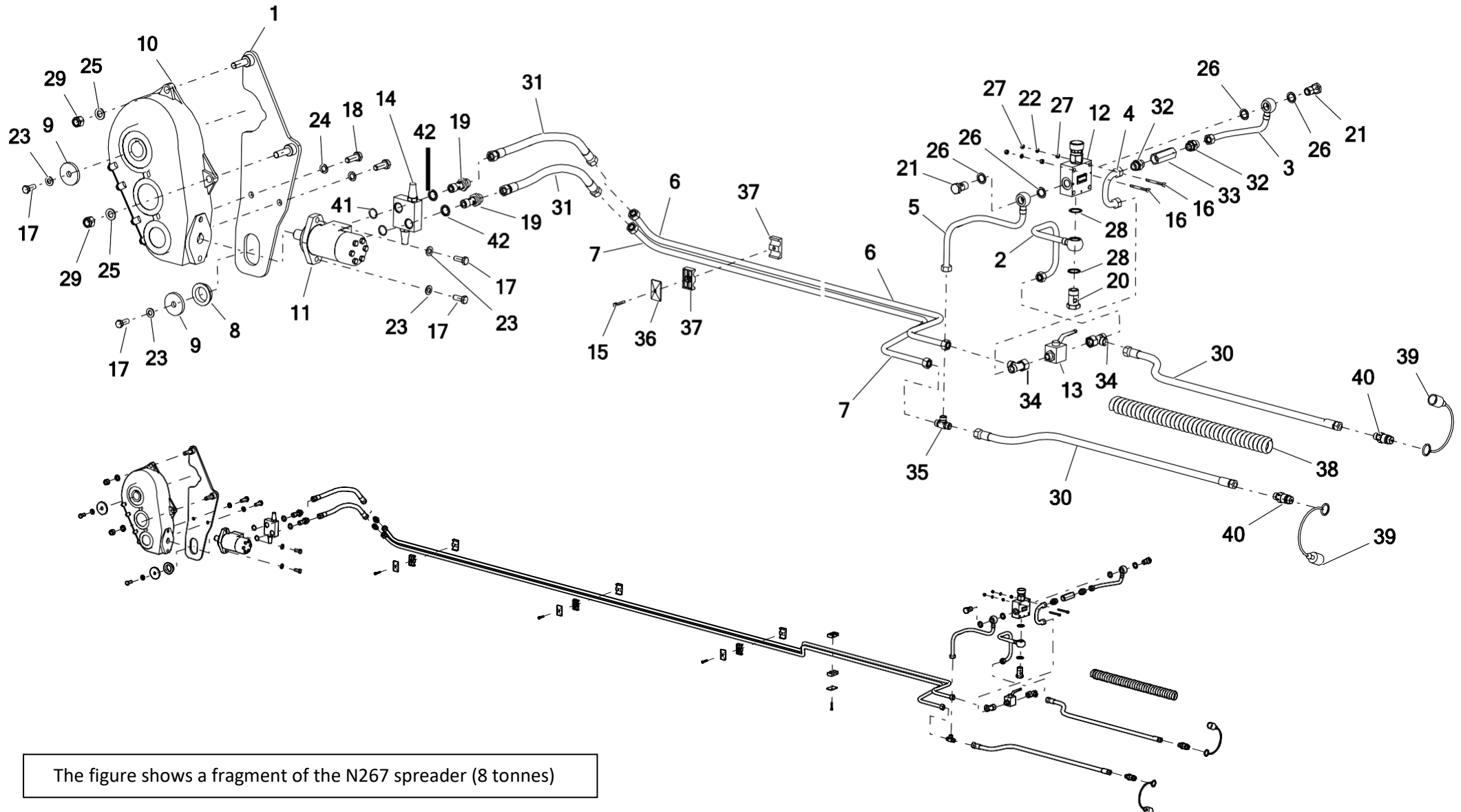

The figure shows a fragment of the N267 spreader (8 tonnes)

No.	Part or assembly name	Fig. or index No.					
		N267	Volume	N267/1	Volume	N267/2	Volume
17	Screw 12 x 30gal 8.8 82105 82105	23S12/30 galv. 8.8	4	23S12/30 galv. 8.8	4	23S12/30 galv. 8.8	4
18	Bolt 14 x 40 galv. 8.8 82105 82105	23S14/40 8.8	2	23S14/40 8.8	2	23S14/40 8.8	2
19	Hydraulic connecting bolt 1/2"/M22 x 1.5	POD-HZW-000099	2	POD-HZW-000099	2	POD-HZW-000099	2
20	Eye bolt 3/4" 29 L42	POD-HKR-000019	1	POD-HKR-000019	1	POD-HKR-000019	1
21	Eye bolt 1/2" 20 L36	24SO1/2"	2	24SO1/2"	2	24SO1/2"	2
22	Spring washer 6.1 galv. 82008 82008	23P6SPOC	2	23P6SPOC	2	23P6SPOC	2
23	Round washer 12 galv. 82005	23P12OC	4	23P12OC	4	23P12OC	4
24	Spring washer 14.2 galv. 82008 82008	23P14SP	2	23P14SP	2	23P14SP	2
25	Round washer 16 galv. 82005 82005	23P16OOC	2	23P16OOC	2	23P16OOC	2
26	Metal & rubber washer PPM22 30 x 22	24UPPM22	4	24UPPM22	4	24UPPM22	4
27	Nut M6 galv. 82144 5	23N6OC	4	23N6OC	4	23N6OC	4
28	Metal-rubber washer PPM 3/4" (M27)	POD-HPZ-000052	2	POD-HPZ-000052	2	POD-HPZ-000052	2
29	Self-locking nut M16 galv. 82175 8 82175 8	23NS16OC	2	23NS16OC	2	23NS16OC	2
30	Flexible hydraulic hose	AA/233/13L-3000	1	AA/233/13L-3000	1	AA/233/13L-3000	1
31	Flexible hydraulic hose	RNMB/213/13L-500	2	RNMB/213/13L-500	2	RNMB/213/13L-500	2
32	Straight connector 1/2 edx 22-1.5	24K1/2 22	2	24K1/2 22	2	24K1/2 22	2

### 30. TWO-SECTION HYDRAULIC SYSTEM - conveyor section.

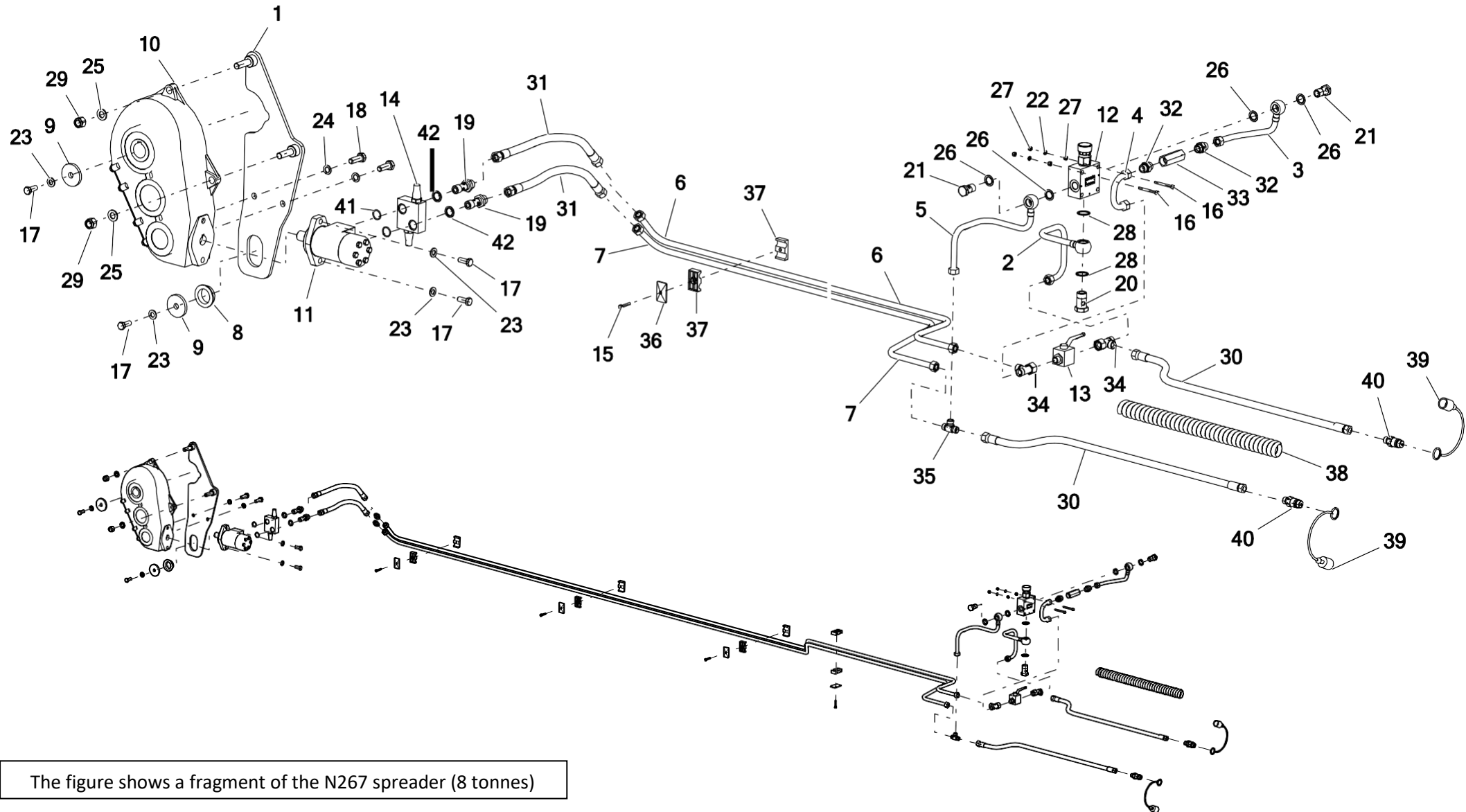

The figure shows a fragment of the N267 spreader (8 tonnes)



No.	Part or assembly name	Fig. or index No.					
		N267	Volume	N267/1	Volume	N267/2	Volume
33	Non-return valve	POD-HZW-000014-1	1	POD-HZW-000014- 1	1	POD-HZW-000014- 1	1
34	Non-symmetrical T-pipe connector 22 x 22 x 22-1.5 15L side nut	POD-HKR-000018	2	POD-HKR-000018	2	POD-HKR-000018	2
35	T-coupling 18 x 18 x 18 12L	24KT18/18/18	1	24KT18/18/18	1	24KT18/18/18	1
36	Handle HBK 15 x 2 - cover	POD-HPZ-000085	4	POD-HPZ-000085	4	POD-HPZ-000085	4
37	Handle HBK 15 x 2 - plastic	POD-HPZ-000085	8	POD-HPZ-000085	8	POD-HPZ-000085	8
38	Spiral guard HG-32/inside diameter 28/ (25-32) L-3500	POD-HPZ-000042-1	1	POD-HPZ-000042-1	1	POD-HPZ-000042-1	1
39	Plug valve cover	24ZWNE13	2	24ZWNE13	2	24ZWNE13	2
40	Quick release coupling M18	24ZWE13-M18x1	2	24ZWE13-M18x1	2	24ZWE13-M18x1	2
41	Rubber washer Ø27	POD-HZW-000099	2	POD-HZW-000099	2	POD-HZW-000099	2
42	Seal ring PPM22 30 x 22	24UPPM22	2	24UPPM22	2	24UPPM22	2

### 31. TWO-SECTION HYDRAULIC SYSTEM - gate valve section.

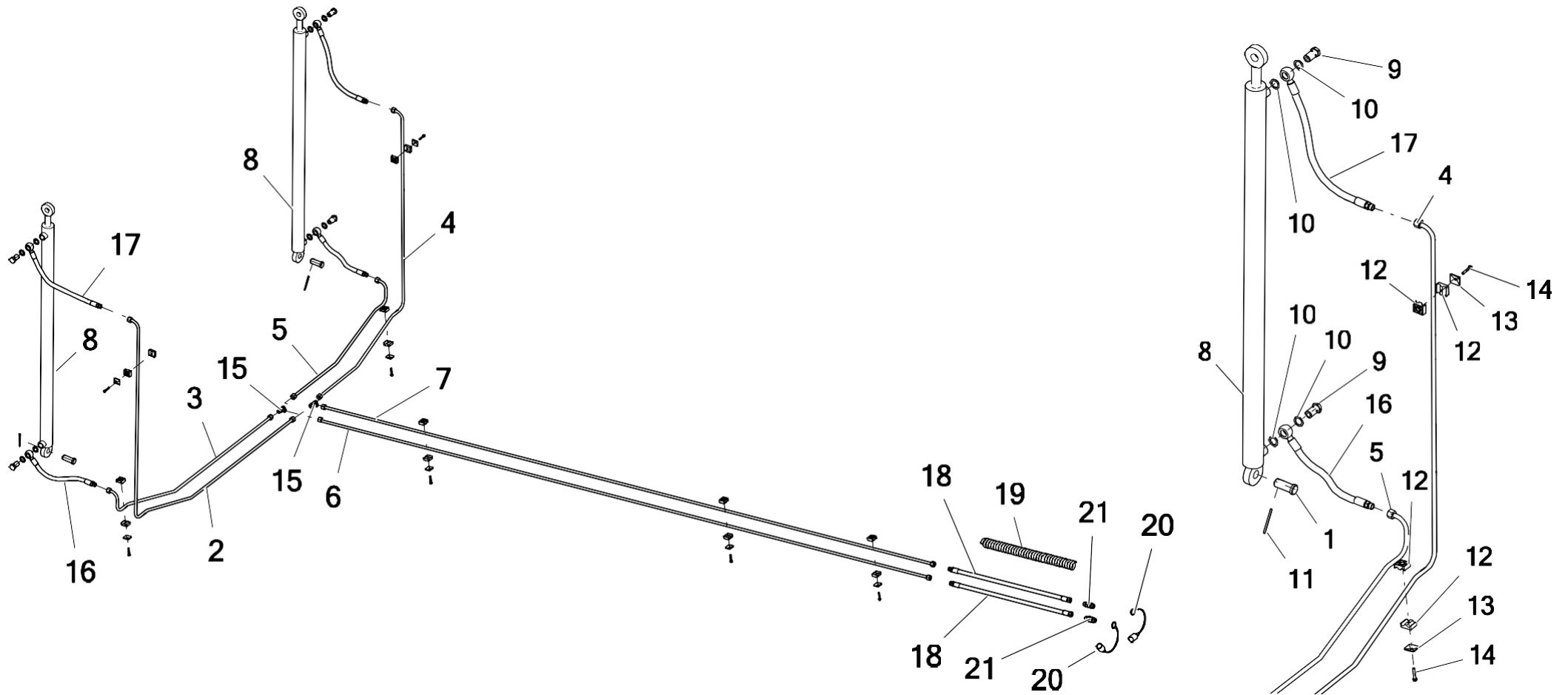

No.	Part or assembly name	Fig. or index No.					
		N267	Volume	N267/1	Volume	N267/2	Volume
1	Actuator bottom pin	N267 00.00.33	2	N267 00.00.33	2	N267 00.00.33	2
2	Steel hydraulic hose Ø12	N267 16.00.03	1	N267-1 16.00.03	1	N267 16.00.03	1
3	Steel hydraulic hose Ø12	N267 16.00.04	1	N267 16.00.04	1	N267 16.00.04	1
4	Steel hydraulic hose Ø12	N267 16.00.05	1	N267-1 16.00.05	1	N267 16.00.05	1
5	Steel hydraulic hose Ø12	N267 16.00.06	1	N267 16.00.06	1	N267 16.00.06	1
6	Steel hydraulic hose Ø12	N267 16.00.07	1	N267-1 16.00.07	1	N267 16.00.07	1
7	Steel hydraulic hose Ø12	N267 16.00.08	1	N267-1 16.00.08	1	N267 16.00.08	1
8	Cylinder USJ2F-50/28/1200 L-1377	POD-HSL-000027-1	2	-----	---	POD-HSL-000027-1	2
	Cylinder USJ2F-50/28/1000 L-1232	-----	---	POD-HSL-000026-1	2	-----	---
9	Eye bolt M22 x 1.5 22 L38	POD-HPZ-000009-1	4	POD-HPZ-000009-1	4	POD-HPZ-000009-1	4
10	Copper washer Ø22 x 28 x 1.5	24U22	8	24U22	8	24U22	8
11	Cotter pin 5 x 63 galv.	23Z5/63	2	23Z5/63	2	23Z5/63	2
12	Handle HBK 12 x 2 - plastic	POD-HPZ-000010-1	14	POD-HPZ-000010-1	14	POD-HPZ-000010-1	14
13	Handle HBK 12 x 2 - cover	POD-HPZ-000010-1	7	POD-HPZ-000010-1	7	POD-HPZ-000010-1	7
14	Bolt 6 x 35 galv. 8.8 82105	23S6/35OC	7	23S6/35OC	7	23S6/35OC	7
15	Tee connector 18 x 18 x 18 12L	24KT18/18/18	2	24KT18/18/18	2	24KT18/18/18	2

### 32. TWO-SECTION HYDRAULIC SYSTEM - gate valve section.

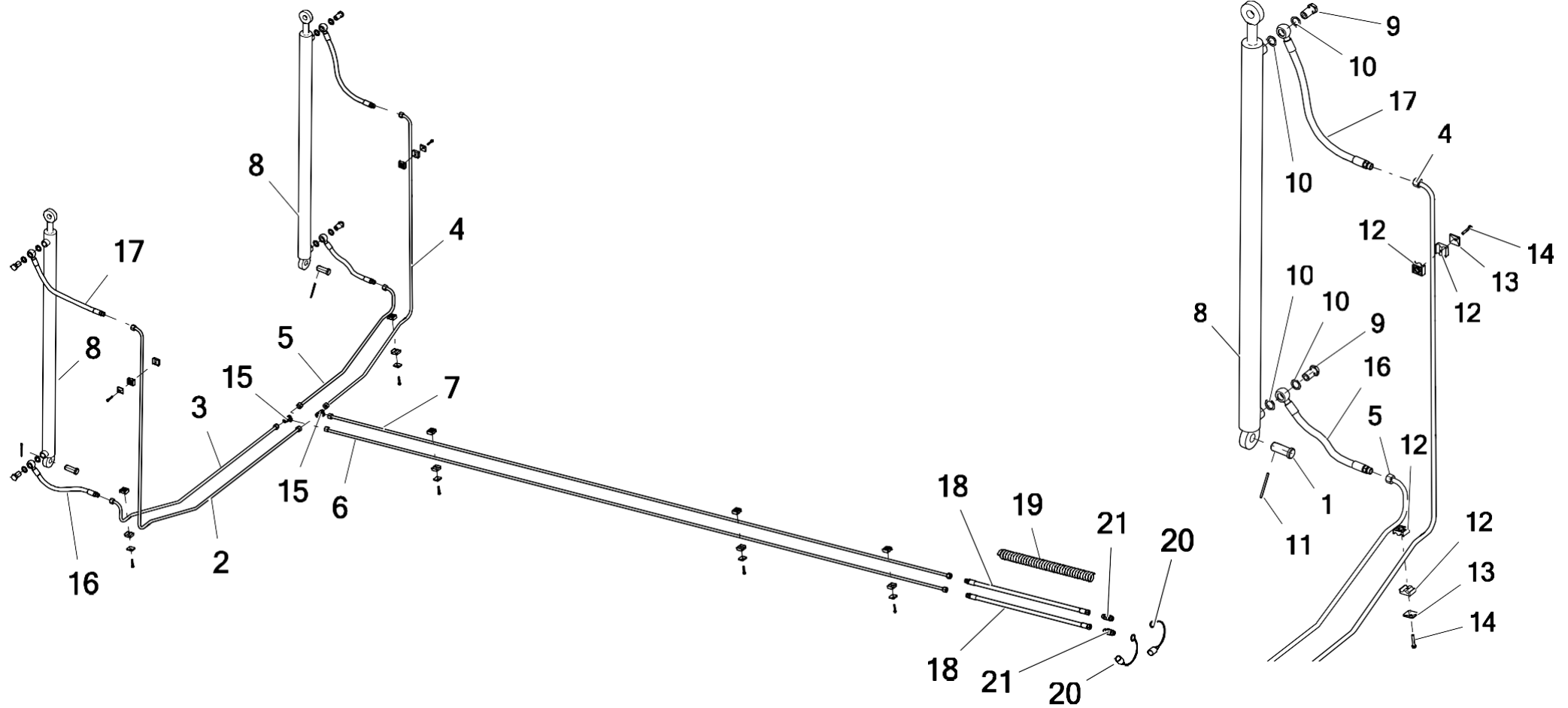

No.	Part or assembly name	Fig. or index No.					
		N267	Volume	N267/1	Volume	N267/2	Volume
16	Flexible hydraulic hose	RNMB/2 1/10 L-400	2	RNMB/2 1/10 L-400	2	RNMB/2 1/10 L-400	2
17	Flexible hydraulic hose	RNMB/2 1/10 L-500	2	RNMB/2 1/10 L-500	2	RNMB/2 1/10 L-500	2
18	Flexible hydraulic hose	BA/211/10 L-3000	2	BA/211/10 L-3000	2	BA/211/10 L-3000	2
19	Spiral guard HG-32/inside diameter 28/ (25-32) L-3500	POD-HPZ-000042-1	1	POD-HPZ-000042-1	1	POD-HPZ-000042-1	1
20	Plug valve cover	24ZWNE13	2	24ZWNE13	2	24ZWNE13	2
21	EURO valve plug M18 x 1.5	24WE13-M18x1.5	2	24WE13-M18x1.5	2	24WE13-M18x1.5	2

**Key:**

**N267 spreader (8 tonnes);** the following items are also included as: **22-3 set 8T spreader - POD-HPR-000611**

Item 28, No. 2 - Hydraulic hose Steel Ø15 - N267 16.00.10 - 1 piece

No. 3 - Hydraulic hose Steel Ø15 - N267 16.00.11 - 1 piece

No. 4 - Hydraulic hose Steel Ø15 - N267 16.00.12 - 1 piece

No. 5 - Hydraulic hose Steel Ø15 - N267 16.00.13 - 1 piece

No. 6 - Hydraulic hose Steel Ø15 - N267 16.00.02 - 1 piece

No. 7 - Hydraulic hose Steel Ø15 - N267 16.00.01 - 1 piece

Item 29, No. 30 - Hydraulic hose Flexible AA/233/13 L-3000 – 2 pieces

No. 31 - Hydraulic hose Flexible RNMB/213/13L - 500 - 2 pieces

Item 31, No. 2 - Hydraulic hose Steel Ø15 - N267 16.00.03 - 1 piece

No. 3 - Hydraulic hose Steel Ø15 - N267 16.00.04 - 1 piece

No. 4 - Hydraulic hose Steel Ø15 - N267 16.00.05 - 1 piece

No. 5 - Hydraulic hose Steel Ø15 - N267 16.00.06 - 1 piece

No. 6 - Hydraulic hose Steel Ø15 - N267 16.00.07 - 1 piece

No. 7 - Hydraulic hose Steel Ø15 - N267 16.00.08 - 1 piece

No. 31 - Hydraulic hose Flexible AB/213/13 L-500 – 2 pieces

Item 32, No. 16 – Hydraulic hose Flexible RNMB/2\_1/10 L-400 (M22 mesh) - 2 pieces

No. 17 – Hydraulic hose Flexible RNMB/2\_1/10 L-500 (M22 mesh) - 2 pieces

**N267/1 spreader (6 tonnes);** the following items are also included as: **21-2 set 8T spreader - POD-HPR-000619**

Item 28, No. 2 - Hydraulic hose Steel Ø15 - N267 16.00.10 - 1 piece

No. 3 - Hydraulic hose Steel Ø15 - N267 16.00.11 - 1 piece

No. 4 - Hydraulic hose Steel Ø15 - N267 16.00.12 - 1 piece

No. 5 - Hydraulic hose Steel Ø15 - N267 16.00.13 - 1 piece

No. 6 - Hydraulic hose Steel Ø15 - N267-1 16.00.02 - 1 piece

No. 7 - Hydraulic hose Steel Ø15 - N267-1 16.00.01 - 1 piece

Item 29, No. 30 - Hydraulic hose Flexible AA/233/13 L-3000 – 2 pieces

No. 31 - Hydraulic hose Flexible RNMB/213/13L - 500 - 2 pieces

Item 31, No. 2 - Hydraulic hose Steel Ø15 - N267-1 16.00.03 - 1 piece

No. 3 - Hydraulic hose Steel Ø15 - N267 16.00.04 - 1 piece

No. 4 - Hydraulic hose Steel Ø15 - N267-1 16.00.05 - 1 piece

No. 5 - Hydraulic hose Steel Ø15 - N267 16.00.06 - 1 piece

No. 6 - Hydraulic hose Steel Ø15 - N267-1 16.00.07 - 1 piece

No. 7 - Hydraulic hose Steel Ø15 - N267-1 16.00.08 - 1 piece

Item 32, No. 16 – Hydraulic hose Flexible RNMB/2\_1/10 L-400 (M22 mesh) - 2 pieces

No. 17 – Hydraulic hose Flexible RNMB/2\_1/10 L-500 (M22 mesh) - 2 pieces

**N267/2 spreader (10 tonnes);** the following items are also included as: **22-4 set 10T spreader - POD-HPR-000850**

Item 28, No. 2 - Hydraulic hose Steel Ø15 - N267 16.00.10 - 1 piece

No. 3 - Hydraulic hose Steel Ø15 - N267 16.00.11 - 1 piece

No. 4 - Hydraulic hose Steel Ø15 - N267 16.00.12 - 1 piece

No. 5 - Hydraulic hose Steel Ø15 - N267 16.00.13 - 1 piece

No. 6 - Hydraulic hose Steel Ø15 - N267-2 16.00.01 - 1 piece

No. 7 - Hydraulic hose Steel Ø15 - N267-2 16.00.02 - 1 piece

Item 29, No. 30 - Hydraulic hose Flexible AA/233/13 L-3000 – 2 pieces

No. 31 - Hydraulic hose Flexible RNMB/213/13L - 500 - 2 pieces

- Item 31, No. 2 - Hydraulic hose Steel Ø15 - N267 16.00.03 - 1 piece
- No. 3 - Hydraulic hose Steel Ø15 - N267 16.00.04 - 1 piece
- No. 4 - Hydraulic hose Steel Ø15 - N267 16.00.05 - 1 piece
- No. 5 - Hydraulic hose Steel Ø15 - N267 16.00.06 - 1 piece
- No. 6 - Hydraulic hose Steel Ø15 - N267 16.00.07 - 1 piece
- No. 7 - Hydraulic hose Steel Ø15 - N267 16.00.08 - 1 piece
- Item 32, No. 16 – Hydraulic hose Flexible RNMB/2\_1/10 L-400 (M22 mesh) - 2 pieces
- No. 17 – Hydraulic hose Flexible RNMB/2\_1/10 L-500 (M22 mesh) - 2 pieces

### 33. BRAKING SYSTEM with ALB

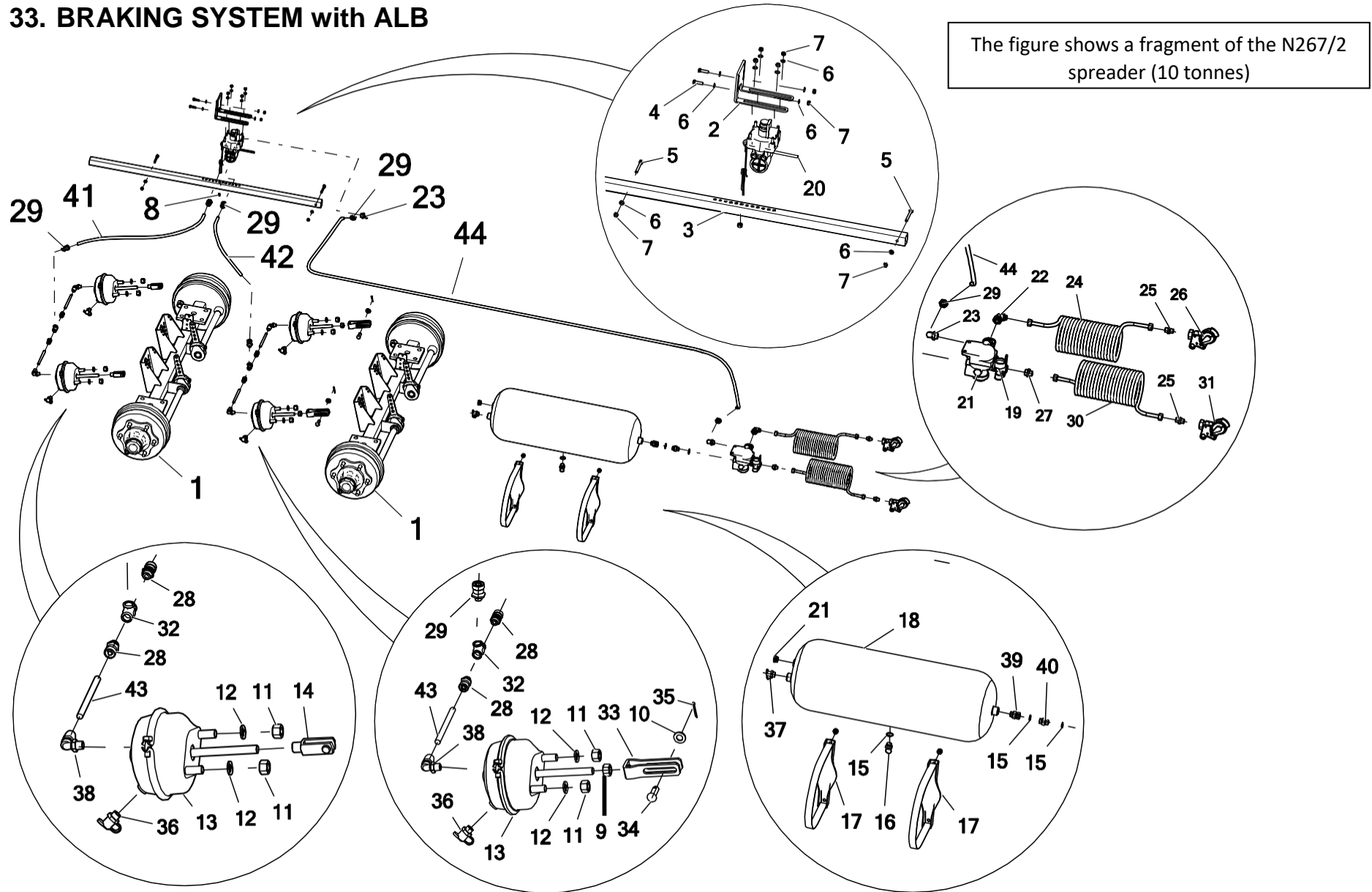



No.	Part or assembly name	Fig. or index No.					
		N267	Volume	N267/1	Volume	N267/2	Volume
1	Axle, complete	-----	---	-----	---	N280 01.50.00.1	2
2	ALB valve support	-----	---	-----	---	N280 21.00.02A2	1
3	ALB connecting profile	-----	---	-----	---	N280 21.00.01A2	1
4	Bolt 8 x 30 galv. 8.8 82105 82105	-----	---	-----	---	23S8/30OC 8.8	2
5	Bolt 8 x 70 galv. 8.8 82101 82101	-----	---	-----	---	23S8/70OC	2
6	Round washer 8 galv. 82005 82005	-----	---	-----	---	23P8OOC	10
7	Self-locking nut M8 galv. 82175 8 82175 8	-----	---	-----	---	23NS8OC	8
8	Nut M10 galv. 82144 5	-----	---	-----	---	23N10OC	1
9	Fine-threaded nut M16 x 1.5 galv. 82144	-----	---	-----	---	POD-ELZ-000764	2
10	Round washer 14 galv. 82005 82005	-----	---	-----	---	23P14OC	2
11	Nut M16 galv. 8.8 82144 5 82144 5	-----	---	-----	---	23N16OC	8
12	Spring washer 16.3 galv. 82008 82008	-----	---	-----	---	23P16SP	8
13	Membrane cylinder 16"	-----	---	-----	---		4
14	Short forks for membrane cylinder HALDEX/KNORR	-----	---	-----	---	DIN 71752-M12-48	2
15	Seal ring PPM22 30 x 22	-----	---	-----	---	24UPPM22	3
16	Drain valve	-----	---	-----	---	23ZODW.	1
17	Ø276 KNORR clamping ring for a 60l air tank	-----	---	-----	---	POD-UGL-000633	2

### 34. BRAKING SYSTEM with ALB

The figure shows a fragment of the N267/2 spreader (10 tonnes)

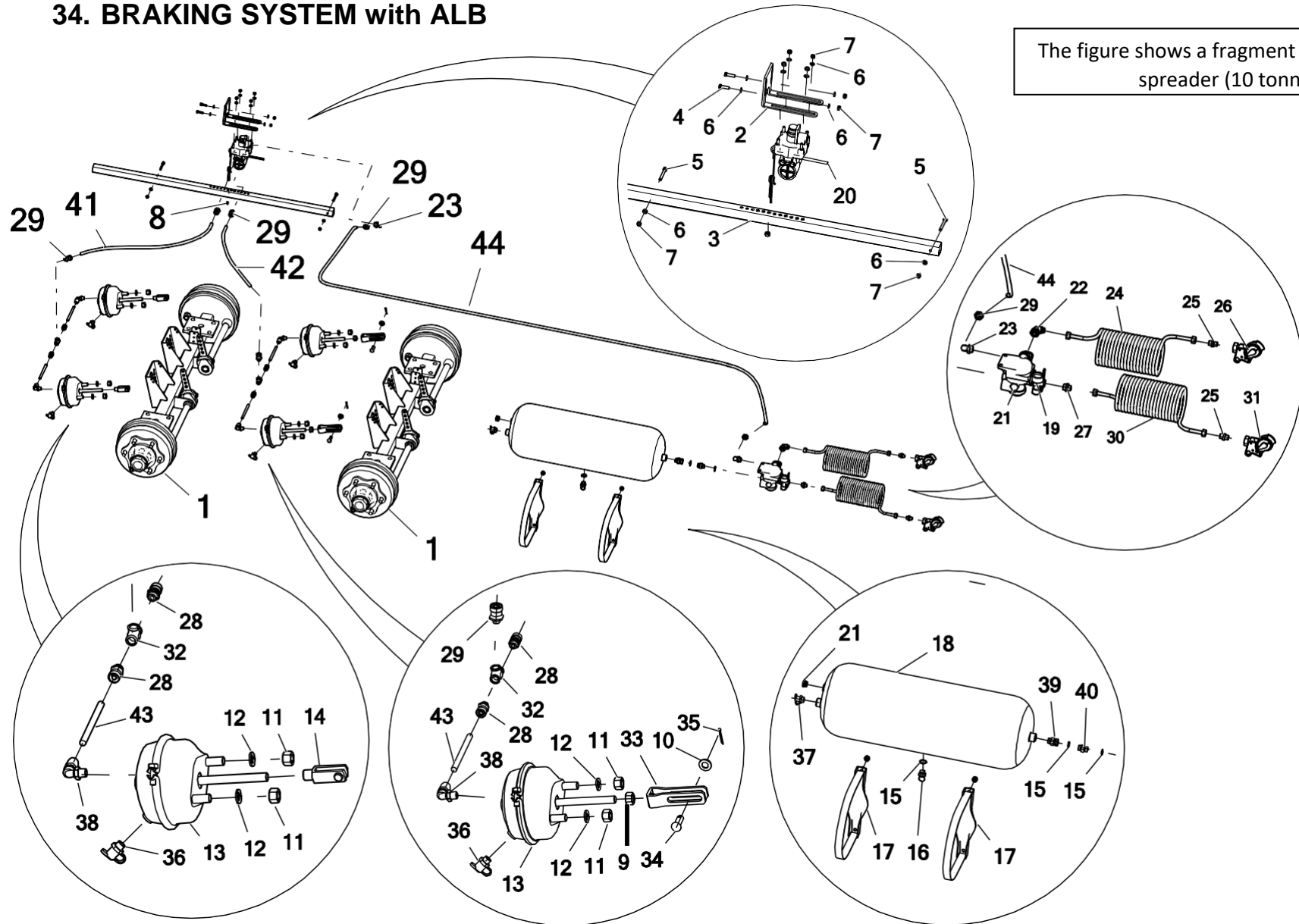

No.	Part or assembly name	Fig. or index No.					
		N267	Volume	N267/1	Volume	N267/2	Volume
18	Ø276 KNORR 40l air tank	-----	---	-----	---	POD-UGL-000847	1
19	Brake valve release 352 012 001 HALDEX	-----	---	-----	---	POD-UGL-001044	1
20	ALB BR4370 valve	-----	---	-----	---		1
21	Pneumatic plug M22	-----	---	-----	---	POD-PZŁ-000037	2
22	Pneumatic elbow M22-18 x 1.5	-----	---	-----	---	POD-PZŁ	1
23	Elbow connector M22-M16 for KNORR	-----	---	-----	---		2
24	HALDEX yellow spiral conduit	-----	---	-----	---	POD-UGL-000620	1
25	Straight connector 16 x 1.5-18 x 1.5	-----	---	-----	---	POD-HKR-000078	2
26	HALDEX conduit connector, yellow, front	-----	---	-----	---	POD-UGL-000625	1
27	Straight pneumatic connector M22-M18	-----	---	-----	---	POD-PZŁ-000010	1
28	Straight connector M16/12 mm	-----	---	-----	---		4
29	Straight connector M22/15 mm	-----	---	-----	---		6
30	HALDEX red spiral conduit	-----	---	-----	---	POD-UGL-000619	1
31	HALDEX conduit connector, red, front	-----	---	-----	---	POD-UGL-000624	1
32	T-piece M16 x 3	-----	---	-----	---		2
33	Forks for membrane cylinder HALDEX/KNORR, long	-----	---	-----	---	POD-UGL-000615	2

### 35. BRAKING SYSTEM with ALB

The figure shows a fragment of the N267/2 spreader (10 tonnes)

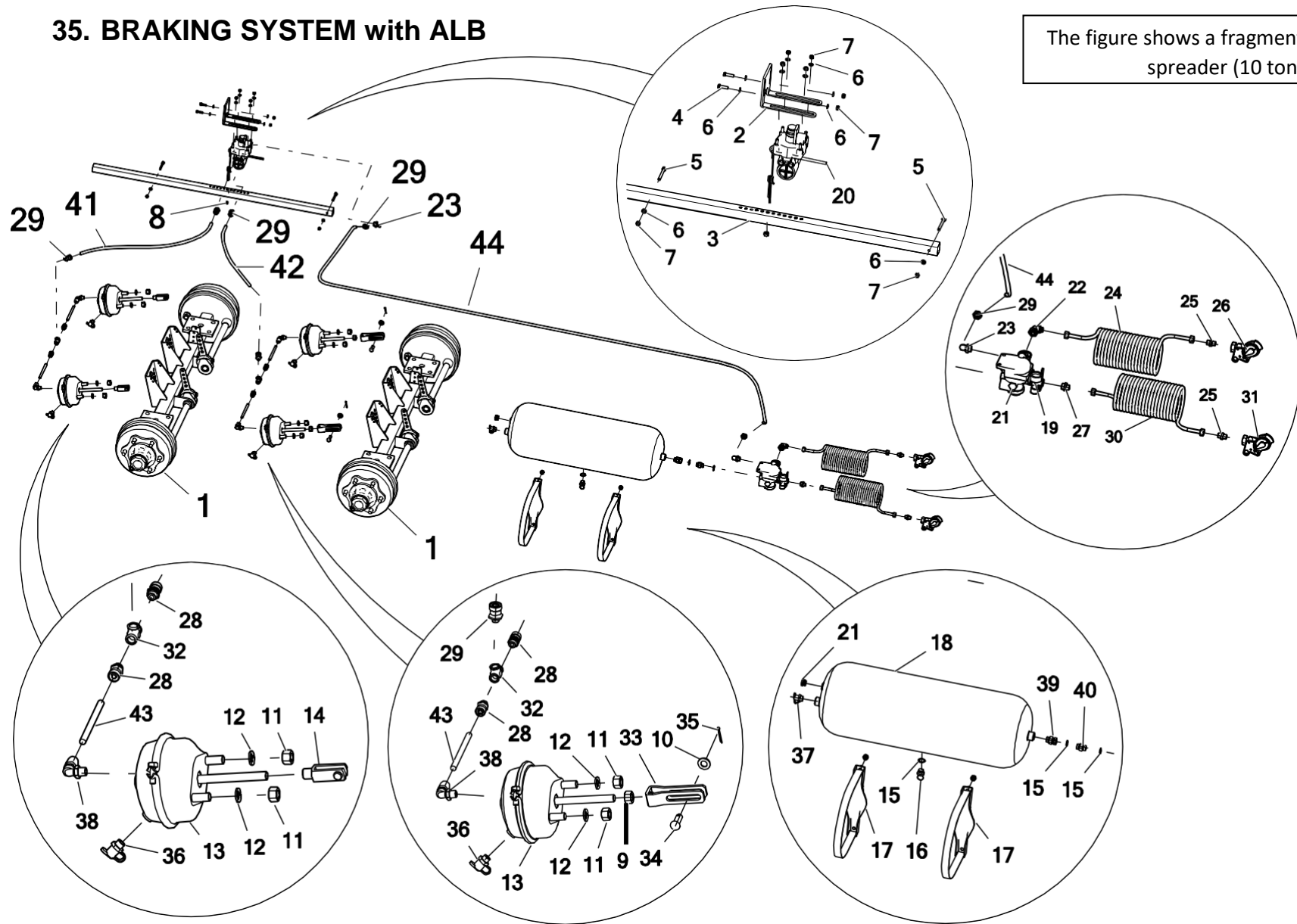

No.	Part or assembly name	Fig. or index No.					
		N267	Volume	N267/1	Volume	N267/2	Volume
34	Actuator Fork Bolt	-----	---	-----	---		2
35	Cotter pin 4 x 32 galv.	-----	---	-----	---	POD-ELZ-000542	2
36	Pneumatic control connector M16 x 1.5	-----	---	-----	---	POD-PZŁ-000039	4
37	Pneumatic control connector M22 x 1.5	-----	---	-----	---	POD-OGŁ-000069	1
38	Pneumatic elbow M16-12 x 1.5	-----	---	-----	---	POD-PZŁ-000015	4
39	Straight connector M22, ext. – M22 x 1.5, nut diam. 15	-----	---	-----	---	POD-HKR-000041	1
40	Straight connector 16 x 1.5-18 x 1.5	-----	---	-----	---	24K22-22	1
41	Tekalan DN15 x 1.5 L~ pipe	-----	---	-----	---	POD-TSZ-000050	1
42	Tekalan DN15 x 1.5 L~ pipe	-----	---	-----	---	POD-TSZ-000050	1
43	Tekalan DN12 x 1.5 L~ pipe	-----	---	-----	---	POD-TSZ-000051	4
44	Tekalan DN15 x 1.5 L~ pipe	-----	---	-----	---	POD-TSZ-000050	1

**Key:**

**No. 11, 12, 13, 14**, - in this configuration, they are only available under a single index No. **POD-OGL-001091 - 16" membrane cylinder + KNORR short fork.**

**No. 9, 10, 11, 12, 13, 33, 35** - in this configuration, they are only available under a single index No. **POD-OGL-001092 - 16" membrane cylinder + KNORR long fork.**

The following items are included in the following:

**KNORR braking system for N280 spreader with ALB connectors, under index No. POD-OGL-001093**

Item 33, No. 16 - Drain valve - 1 piece

Item 34, No. 21 - Pneumatic plug M22 (Plug M22 x 1.5) - 3 pieces

No. 23 - Elbow connector M22-M16 for KNORR (external elbow M22 / int. M16) – 2 pieces

No. 28 - Straight connector M16/12 mm (external straight threaded connector M16 / Ø12 Raufoss) – 4 pieces

No. 29 - Straight connector M22/15 mm (external straight threaded connector M22 / Ø15 Raufoss) – 4 pieces

No. 32 - T-pipe M16 x 3 (T-pipe, 3x int. thread M16) – 2 pieces

Item 35, No. 36 - Pneumatic control connector M16 x 1.5 (control connector M16) - 4 pieces

No. 37 - Pneumatic control connector M22 x 1.5 9 (control connector M22) - 1 piece

No. 38 - Pneumatic elbow M16-12 x 1.5 (ext. threaded elbow M16 / int. thread M16) – 2 pieces

No. 39 – Ext. bulkhead connector M22 / ext. M22 / int. M22 – 1 piece

No. 40 - Straight connector 16 x 1.5/ 18 x 1.5 (M18 x M16 nipple) - 1 piece

**KNORR TUV type N braking system, all-purpose, automatic regulation, ALB valves without rear connections - POD-OGL-001094**

Item 34, No. 19 - KNORR BREMSE brake valve for trailer - 1 piece

No. 20 - Mechanical braking force regulator - 1 piece

No. 24 - HALDEX yellow spiral conduit (M16 spiral pneumatic conduit, yellow, MA) - 1 piece

No. 26 - HALDEX conduit connector, yellow, front (yellow head with flow filter) - 1 piece

No. 30 - HALDEX red spiral conduit (M16 spiral pneumatic conduit, red, MAR) - 1 piece

No. 31 - HALDEX conduit connector, red, front (red conduit head with filter) - 1 piece

The set also includes items not shown in the drawings:

**KNORR-BREMSE adjustment plate** - 1 piece

**Holder for heads** – 2 pieces

**36. BRAKING SYSTEM (SPRING SUSPENSION)**

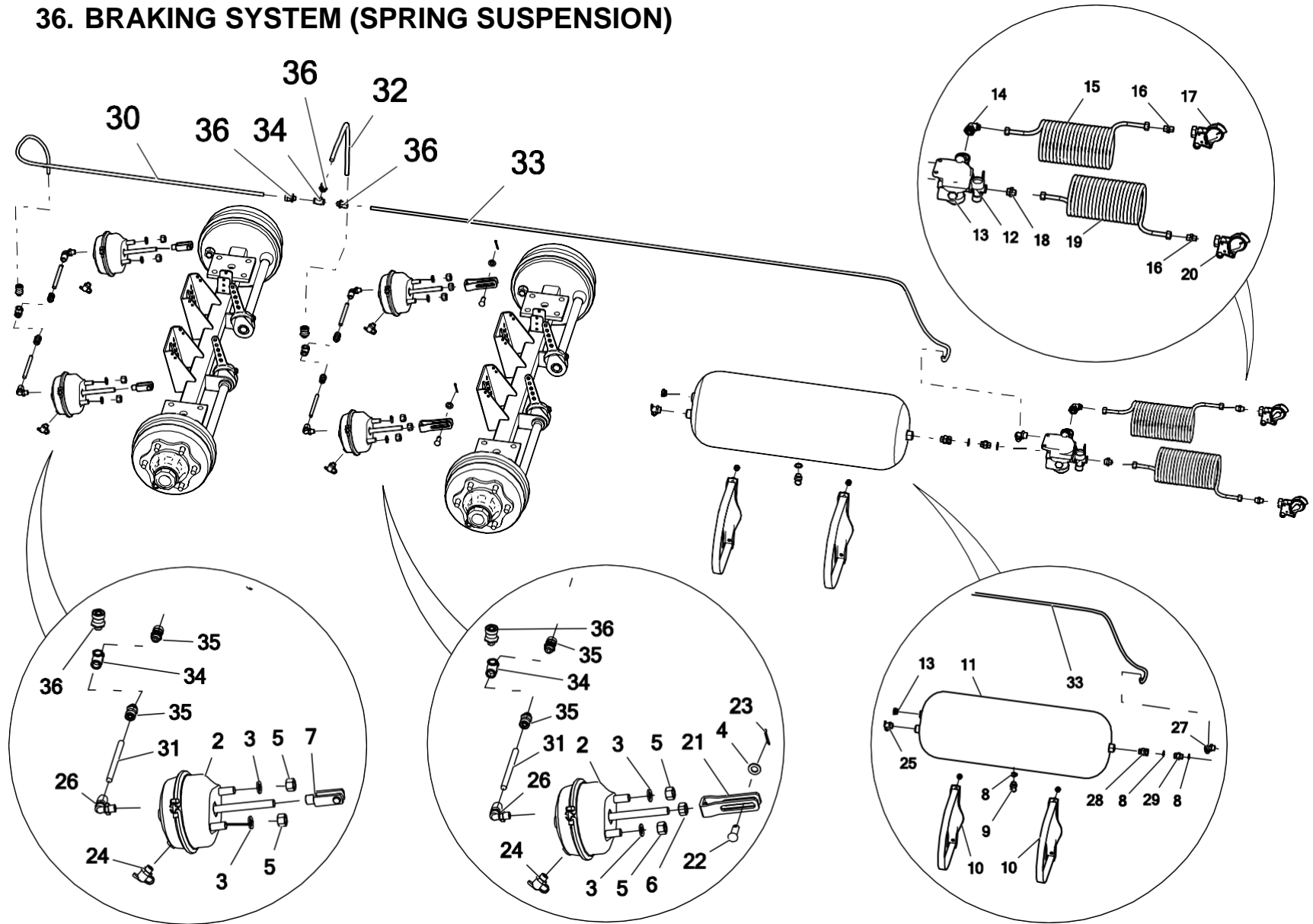

The figure shows a fragment of the N267/2 spreader (10 tonnes)

No.	Part or assembly name	Fig. or index No.					
		N267	Volume	N267/1	Volume	N267/2	Volume
1	Axle, complete	-----	---	-----	---	N280 01.50.00.1	2
2	Membrane cylinder 16"	-----	---	-----	---		4
3	Spring washer 16.3 galv. 82008	-----	---	-----	---	23P16SP	8
4	Round washer 14 galv. 82005 2005	-----	---	-----	---	23P14OC	2
5	Nut M16 galv. 8.8 82144 5 82144 5	-----	---	-----	---	23N16OC	8
6	Fine-threaded nut M16 x 1.5 galv. 82144	-----	---	-----	---	POD-ELZ-000764	2
7	Short forks for membrane cylinder HALDEX/KNORR	-----	---	-----	---	DIN71752-M12-48	2
8	Sealing ring PPM22 3022	-----	---	-----	---	24UPPM22	3
9	Drain valve 83 10 011 0	-----	---	-----	---	23ZODW	1
10	Tank base with a clamp	-----	---	-----	---		2
11	Air tank 40 l Ø310	-----	---	-----	---		1
12	Brake valve with a manual braking force regulator	-----	---	-----	---	350028001	1
13	Pneumatic plug M22	-----	---	-----	---	POD-PZŁ-000037	2
14	Pneumatic elbow M22-18x1.5	-----	---	-----	---	POD-PZŁ	1
15	HALDEX yellow spiral conduit	-----	---	-----	---	POD-UGL-000620	1
16	Straight connector 16 x 1.5-18 x 1.5	-----	---	-----	---	POD-HKR-000078	2



**37. BRAKING SYSTEM (SPRING SUSPENSION)**

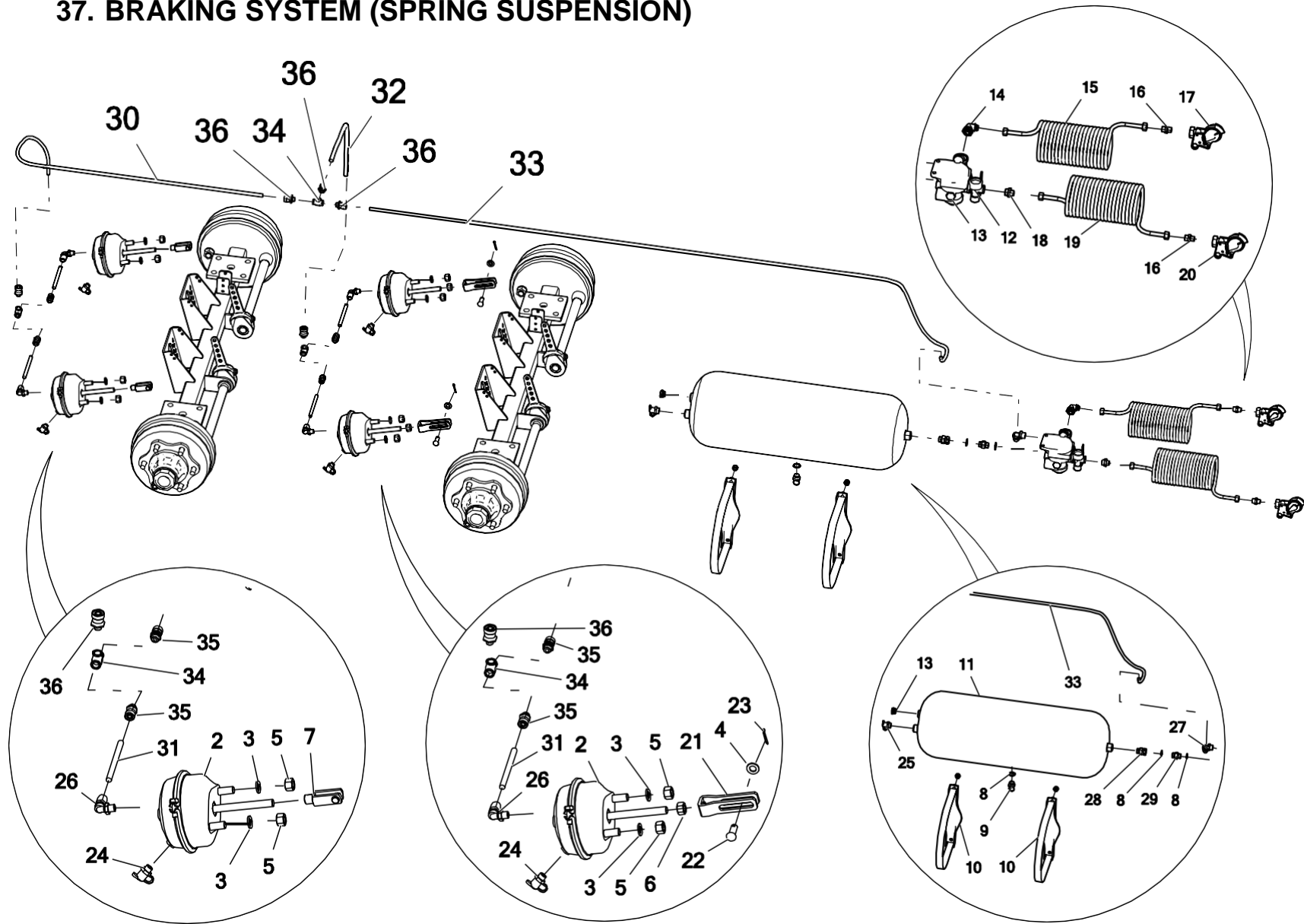

The figure shows a fragment of the N267/2 spreader (10 tonnes)

No.	Part or assembly name	Fig. or index No.					
		N267	Volume	N267/1	Volume	N267/2	Volume
17	HALDEX conduit connector, yellow, front	-----	---	-----	---	POD-UGL-000625	1
18	Straight pneumatic connector M22-M18	-----	---	-----	---	POD-PZŁ-000010	1
19	HALDEX red spiral conduit	-----	---	-----	---	POD-UGL-000619	1
20	HALDEX conduit connector, red, front	-----	---	-----	---	POD-UGL-000624	1
21	Long fork for HALDEX/KNORR membrane cylinder	-----	---	-----	---	POD-UGL-000615	2
22	Actuator Fork Bolt	-----	---	-----	---		2
23	Cotter pin 4 x 32 galv.	-----	---	-----	---	POD-ELZ-000542	2
24	Pneumatic control connector M16 x 1.5	-----	---	-----	---	POD-PZŁ-000039	4
25	Pneumatic control connector M22 x 1.5	-----	---	-----	---	POD-UGL-000069	1
26	Pneumatic elbow M16-12 x 1.5	-----	---	-----	---	POD-PZŁ-000015	4
27	Pneumatic elbow M22 x 1.5 TK12	-----	---	-----	---	POD-PZŁ-000016	1
28	Straight connector M22, ext. - M22 x 1.5 Ø15, screwed-on	-----	---	-----	---	POD-HKR-000041	1
29	Connector	-----	---	-----	---	24K22-22	1
30	DN15 x 1.5 L~ Tekalan pipe	-----	---	-----	---	POD-TSZ-000051	1
31	DN15 x 1.5 L~ Tekalan pipe	-----	---	-----	---	POD-TSZ-000050	4
32	DN15 x 1.5 L~ Tekalan pipe	-----	---	-----	---	POD-TSZ-000051	1

**38. BRAKING SYSTEM (SPRING SUSPENSION)**

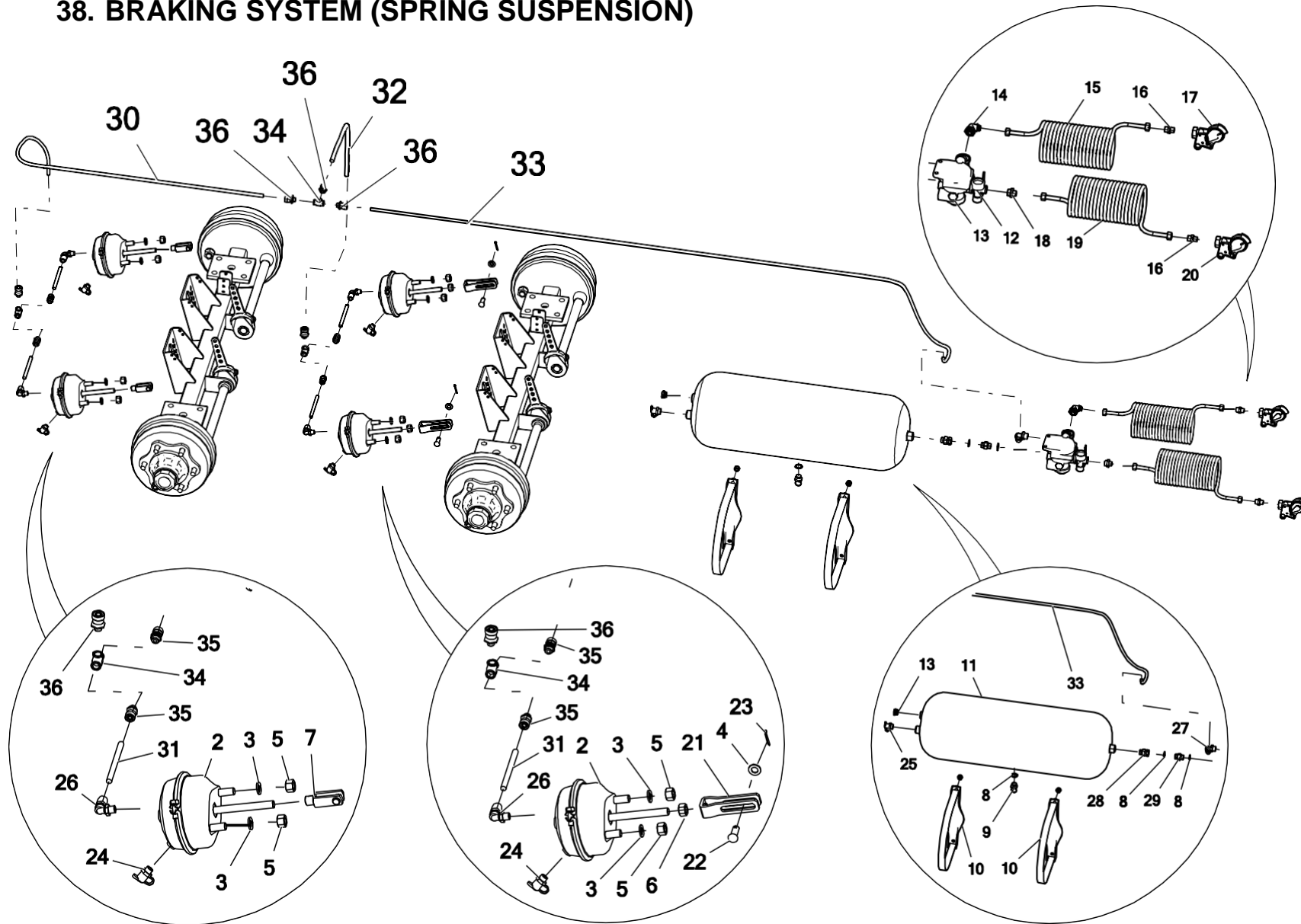

The figure shows a fragment of the N267/2 spreader (10 tonnes)

No.	Part or assembly name	Fig. or index No.					
		N267	Volume	N267/1	Volume	N267/2	Volume
33	DN15 x 1.5 L~ Tekalan pipe	-----	---	-----	---	POD-TSZ-000051	1
34	T-piece M16 x 3	-----	---	-----	---		3
35	Straight connector M16/12 mm	-----	---	-----	---		4
36	Straight connector M22/15 mm	-----	---	-----	---		5

**Key:**

**No. 11, 12, 13, 14,** - in this configuration, they are only available under a single index No. **POD-OGL-001091 - 16" membrane cylinder + KNORR short fork.**

**No. 9, 10, 11, 12, 13, 33, 35** - in this configuration, they are only available under a single index No. **POD-OGL-001092 - 16" membrane cylinder + KNORR long fork.**

The following items are included in the following:

**KNORR braking system for N280 spreader with ALB connectors, under index No. POD-OGL-001093**

Item 33, No. 16 - Drain valve - 1 piece

Item 34, No. 21 - Pneumatic plug M22 (Plug M22 x 1.5) - 3 pieces

No. 23 - Elbow connector M22-M16 for KNORR (external elbow M22 / int. M16) – 2 pieces

No. 28 - Straight connector M16/12 mm (external straight threaded connector M16 / Ø12 Raufoss) – 4 pieces

No. 29 - Straight connector M22/15 mm (external straight threaded connector M22 / Ø15 Raufoss) – 4 pieces

No. 32 - T-pipe M16 x 3 (T-pipe, 3x int. thread M16) – 2 pieces

Item 35, No. 36 - Pneumatic control connector M16 x 1.5 (control connector M16) - 4 pieces

No. 37 - Pneumatic control connector M22 x 1.5 9 (control connector M22) - 1 piece

No. 38 - Pneumatic elbow M16-12 x 1.5 (ext. threaded elbow M16 / int. thread M16) – 2 pieces

No. 39 – Ext. bulkhead connector M22 / ext. M22 / int. M22 – 1 piece

No. 40 - Straight connector 16 x 1.5/ 18 x 1.5 (M18 x M16 nipple) - 1 piece

**KNORR TUV type N braking system, all-purpose, automatic regulation, ALB valves without rear connections - POD-OGL-001094**

Item 34, No. 19 - KNORR BREMSE brake valve for trailer - 1 piece

No. 20 - Mechanical braking force regulator - 1 piece

No. 24 - HALDEX yellow spiral conduit (M16 spiral pneumatic conduit, yellow, MA) - 1 piece

No. 26 - HALDEX conduit connector, yellow, front (yellow head with flow filter) - 1 piece

No. 30 - HALDEX red spiral conduit (M16 spiral pneumatic conduit, red, MAR) - 1 piece

No. 31 - HALDEX conduit connector, red, front (red conduit head with filter) - 1 piece

The set also includes items not shown in the drawings:

**KNORR-BREMSE adjustment plate** - 1 piece

**Holder for heads** – 2 pieces

### 39. 2-LINE PNEUMATIC BRAKING SYSTEM (TANDEM)

The figure shows a fragment of the N267 spreader (8 tonnes)

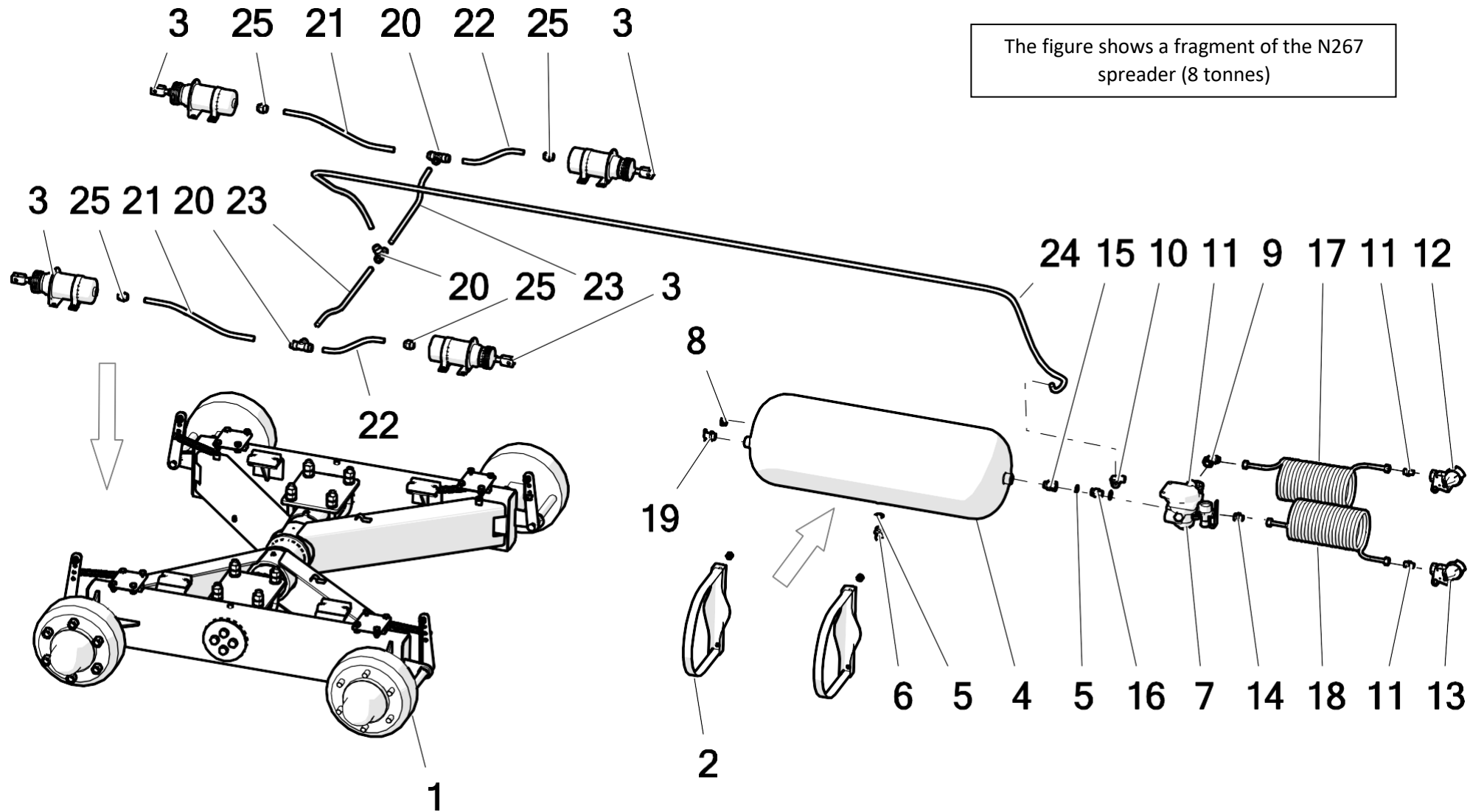

No.	Part or assembly name	Fig. or index No.					
		N267	Volume	N267/1	Volume	N267/2	Volume
1	Tandem, complete	N267 01.00.00	1	N267 01.00.00	1	-----	---
2	Ø276 mm tank clamp	POD-OGL-000513	2	POD-OGL-000513	2	-----	---
3	Air cylinder 53.12.00/A	POD-OGL-000022-1	4	POD-OGL-000022-1	4	-----	---
4	40 l air tank (Ø276)	POD-OGL-000513	1	POD-OGL-000513	1	-----	---
5	Sealing ring PPM22 30 x 22	24UPPM22	2	24UPPM22	2	-----	---
6	Drain Valve M22 x 1.5	POD-OGL-000513	1	POD-OGL-000513	1	-----	---
7	Brake valve with a manual braking force regulator	POD-OGL-000513	1	POD-OGL-000513	1	-----	---
8	Plug M22 x 1.5 + O-ring	POD-OGL-000513	1	POD-OGL-000513	1	-----	---
9	Elbow M22M/M16 with a cone	POD-OGL-000513	1	POD-OGL-000513	1	-----	---
10	Elbow M22 x 1.5 / TK15		1		1	-----	---
11	Straight connector M16 x 1.5/M18 x 1.5	POD-HKR-000078	2	POD-HKR-000078	2	-----	---
12	HALDEX conduit connector, yellow, front	POD-OGL-000625	1	POD-OGL-000625	1	-----	---
13	HALDEX conduit connector, red, front	POD-OGL-000624	1	POD-OGL-000624	1	-----	---
14	Straight pneumatic connector M22-M16	POD-PZŁ-000010	1	POD-PZŁ-000010	1	-----	---
15	Straight connector M22, ext.-M22 x 1.5, diam. 15, screwed-on	POD-HKR-000041	1	POD-HKR-000041	1	-----	---
16	Connector 24K22-22		1		1	-----	---

**40. 2-LINE PNEUMATIC BRAKING SYSTEM (TANDEM)**

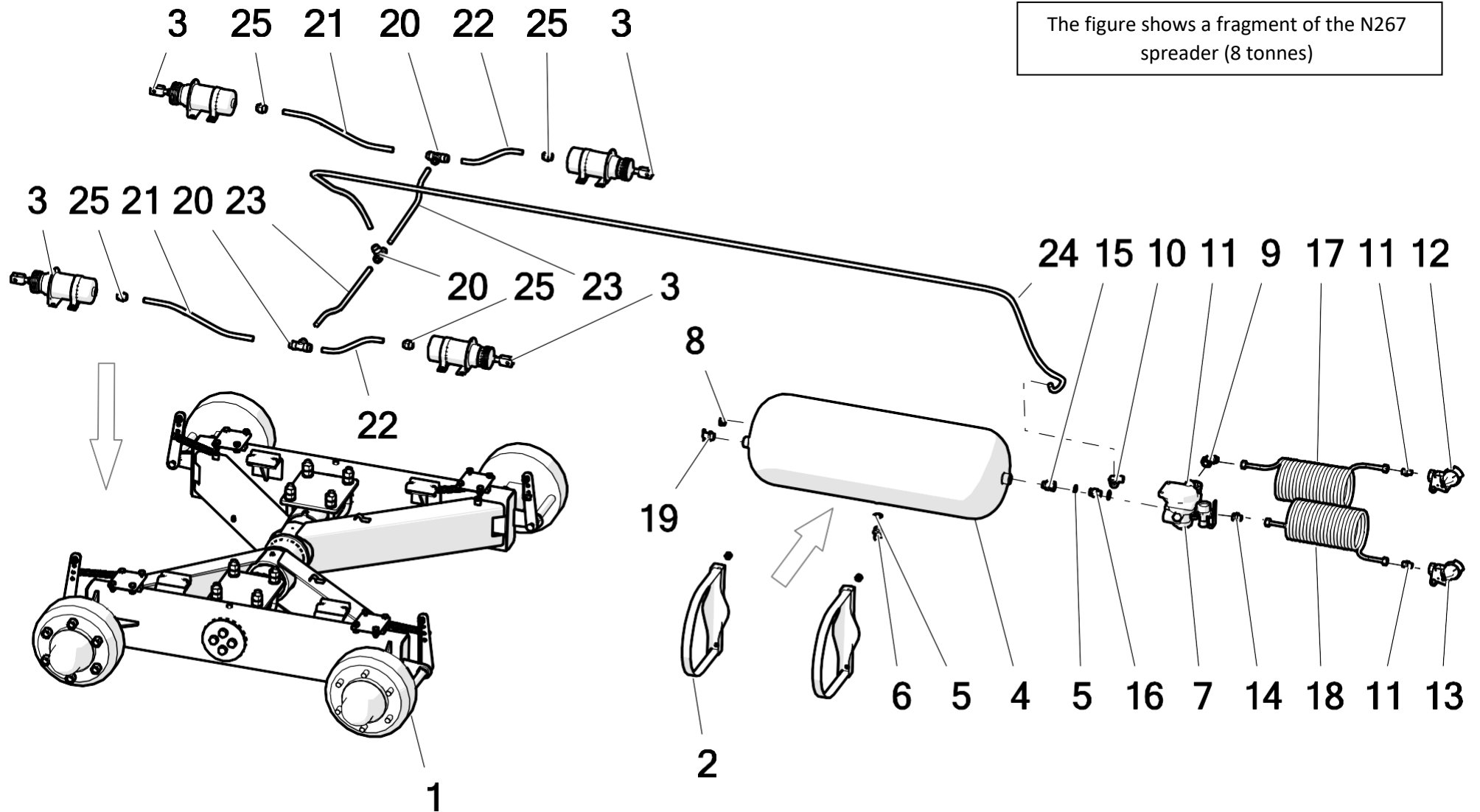



No.	Part or assembly name	Fig. or index No.					
		N267	Volume	N267/1	Volume	N267/2	Volume
17	HALDEX yellow spiral conduit	POD-OGL-000620	1	POD-OGL-000620	1	-----	---
18	HALDEX red spiral conduit	POD-OGL-000619	1	POD-OGL-000619	1	-----	---
19	Pneumatic control connector M22 x 1.5	POD-OGL-000069	1	POD-OGL-000069	1	-----	---
20	Symmetrical tee TK15/TK15/TK15		3		3	-----	---
21	DN15 x 1.5 L~ Tekalan pipe	POD-TSZ-000051	2	POD-TSZ-000051	2	-----	---
22	DN15 x 1.5 L~ Tekalan pipe	POD-TSZ-000051	2	POD-TSZ-000051	2	-----	---
23	DN15 x 1.5 L~ Tekalan pipe	POD-TSZ-000051	2	POD-TSZ-000051	2	-----	---
24	DN15 x 1.5 L~ Tekalan pipe	POD-TSZ-000051	2	POD-TSZ-000051	2	-----	---
25	Pneumatic straight connector M22 TK15		4		4	-----	---

**Key:**

Items marked as (\*) are also available as a ready set: **POD-OGL-000513 - HALDEX/KNORR braking system for N280 spreader, VALVES + CONNECTORS**

**41. 1-LINE PNEUMATIC BRAKING SYSTEM (TANDEM)**

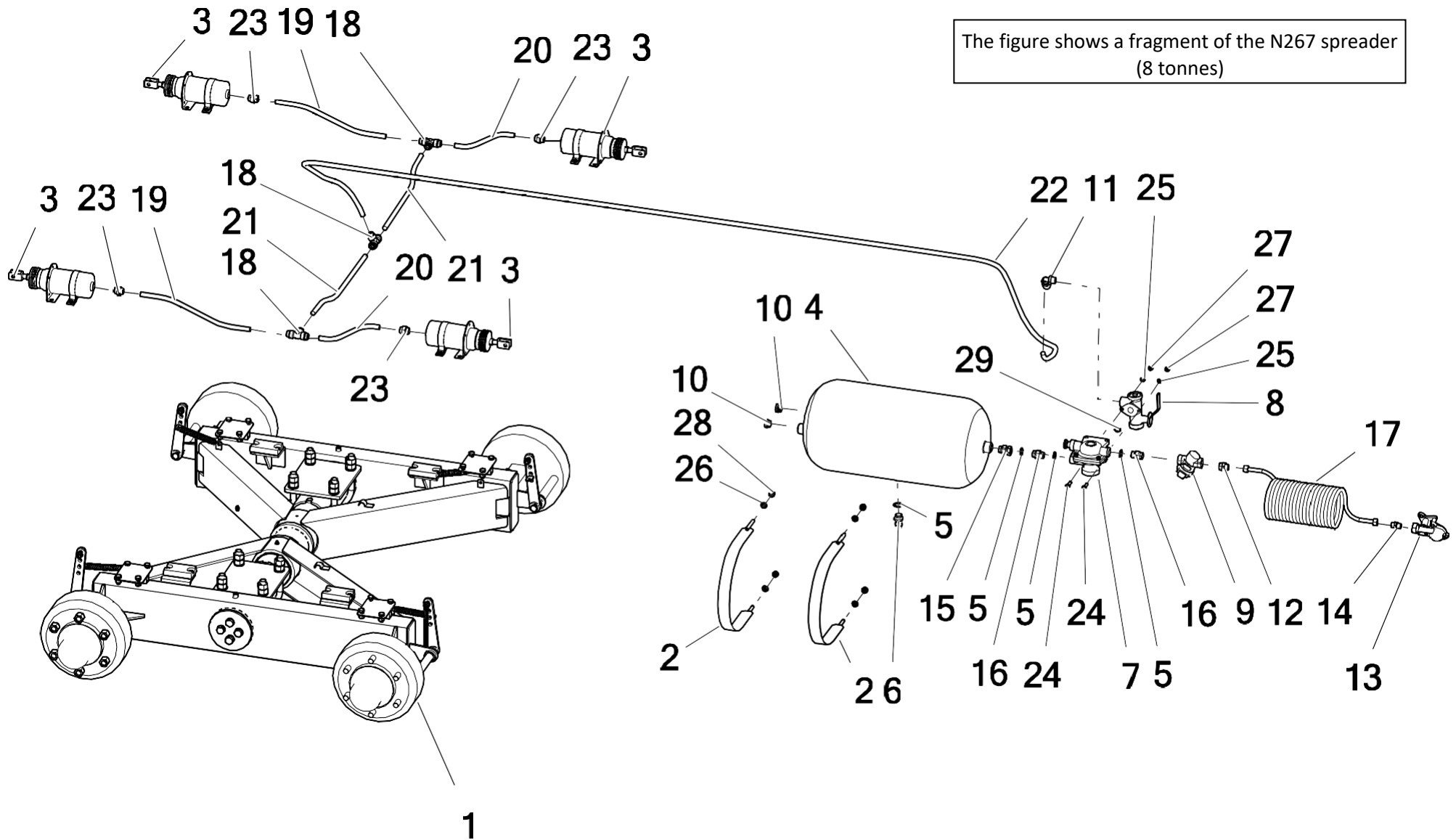

No.	Part or assembly name	Fig. or index No.					
		N267	Volume	N267/1	Volume	N267/2	Volume
1	Tandem, complete	N267 01.00.00	1	N267 01.00.00	1	-----	---
2	Tank clamp, complete	N267 02/01/1950	2	N267 02/01/1950	2	-----	---
3	Air cylinder 53.12.00/A	POD-OGL-000022-1	4	POD-OGL-000022-1	4	-----	---
4	40 l air tank (Ø310)	POD-OGL-000026-1	1	POD-OGL-000026-1	1	-----	---
5	Sealing ring PPM22 30 x 22	24UPPM22	5	24UPPM22	5	-----	---
6	Drain Valve M22 x 1.5	23ODW	1	23ODW	1	-----	---
7	Trailer braking valve 44 11 011 0 - HZS2 distributor	25ZHP	1	25ZHP	1	-----	---
8	3-range braking force regulator 61 11 012 0 + O-ring	POD-OGL-000067	1	POD-OGL-000067	1	-----	---
9	Pneumatic system filter 81 10 010 0	POD-OGL-000021-1	1	POD-OGL-000021-1	1	-----	---
10	Pneumatic plug M22	POD-PZŁ-000037	2	POD-PZŁ-000037	2	-----	---
11	Elbow M22 x 1.5 / TK15		1		1	-----	---
12	Straight pneumatic connector M22-M16	POD-PZŁ-000010	1	POD-PZŁ-000010	1	-----	---
13	Conduit connector, hard, black 87 30 010	25ZP	1	25ZP	1	-----	---
14	Straight connector M16 x 1.5/ M16 x 1.5	POD-HKR-000078	2	POD-HKR-000078	2	-----	---
15	Straight connector M22, ext.-M22 x 1.5, diam. 15, screwed-on	POD-HKR-000041	2	POD-HKR-000041	2	-----	---
16	Connector 24K22-22		2		2	-----	---

### 42. 1-LINE PNEUMATIC BRAKING SYSTEM (TANDEM)

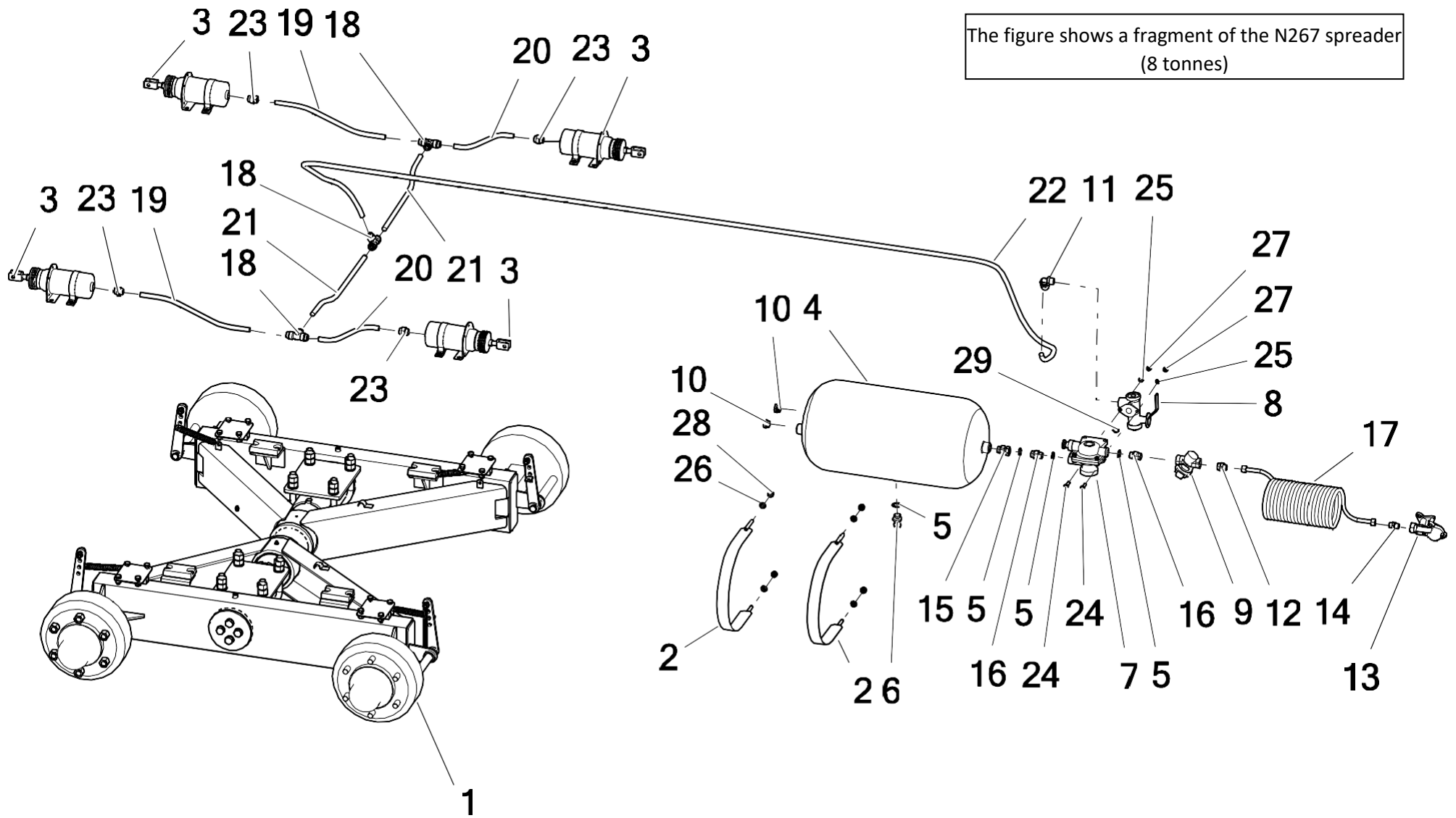

No.	Part or assembly name	Fig. or index No.					
		N267	Volume	N267/1	Volume	N267/2	Volume
17	HALDEX black spiral conduit		1		1	-----	---
18	Symmetrical tee TK15/TK15/TK15		3		3	-----	---
19	DN15 x 1.5 L~ Tekalan pipe	POD-TSZ-000051	2	POD-TSZ-000051	2	-----	---
20	DN15 x 1.5 L~ Tekalan pipe	POD-TSZ-000051	2	POD-TSZ-000051	2	-----	---
21	DN15 x 1.5 L~ Tekalan pipe	POD-TSZ-000051	2	POD-TSZ-000051	2	-----	---
22	DN15 x 1.5 L~ Tekalan pipe	POD-TSZ-000051	2	POD-TSZ-000051	2	-----	---
23	Pneumatic straight connector M22 TK15		4		4	-----	---
24	Bolt 8 x 30 galv. 8.8 82105 82105	23S8/30OC 8.8	2	23S8/30 galv. 8.8	2	-----	---
25	Spring washer 8.2 galv. 82008 82008	23P8SPOC	2	23P8SPOC	2	-----	---
26	Round washer 10 galv. 82005 82005	23P1082005	4	23P1082005	4	-----	---
27	Nut M8 galv. 82144 82144	23N8OC	2	23N8OC	2	-----	---
28	Self-locking nut M10 galv. 82175 82175 8	23NS10OC	4	23NS10OC	4	-----	---

**Key:**

**Item 29** - included in the following set: **3-range braking force regulator 61 11 012 0 + O-ring – POD-OGI-000067 – 1 item - This is an O-ring**

### 43. HYDRAULIC BRAKING SYSTEM (TANDEM)

The figure shows a fragment of the N267 spreader (8 tonnes)

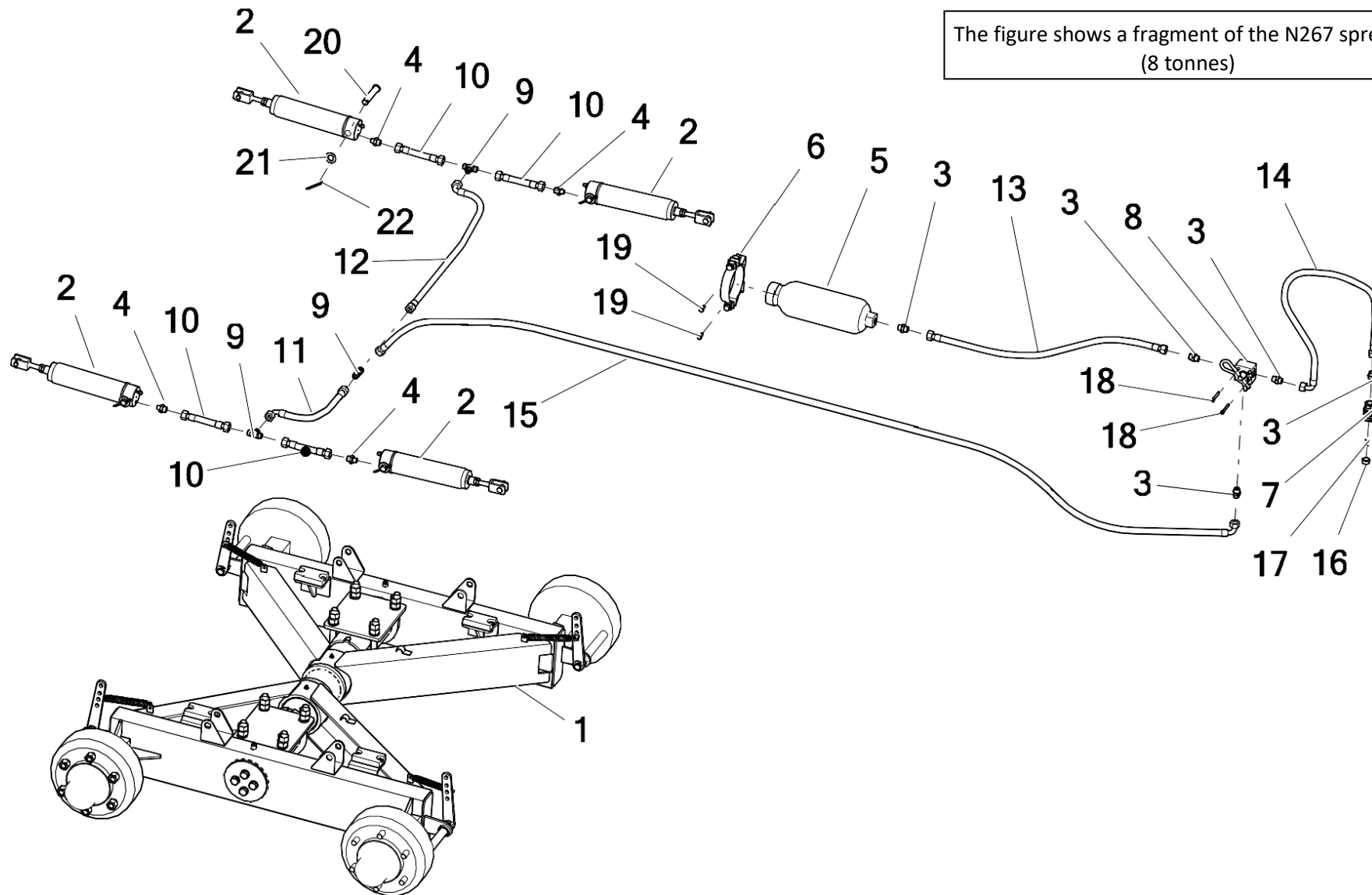

No.	Part or assembly name	Fig. or index No.					
		N267	Volume	N267/1	Volume	N267/2	Volume
1	Tandem, complete	N267 18/01/2000	1	N267 18/01/2000	1	-----	---
2	Brakes - actuator 900408 (21001460)	POD-HPZ-000112	4	POD-HPZ-000112	4	-----	---
3	Straight connector 18 x 18.-1.5	POD-HKR-000040	5	POD-HKR-000040	5	-----	---
4	Straight connector 14 x 1.5-18 x 1.5	POD-HKR-000101	4	POD-HKR-000101	4	-----	---
5	Brakes - hydraulic battery 1.5l (21001971) – 100 bar	POD-HPZ-000114	1	POD-HPZ-000114	1	-----	---
6	Brakes - battery clamp 0.75l-1.5l (21001623)	POD-HPZ-000116	1	POD-HPZ-000116	1	-----	---
7	Quick release coupling 900410 (21001462)	POD-HPZ-000117	1	POD-HPZ-000117	1	-----	---
8	Brakes - emergency valve 900409 (21003208)	POD-HPZ-000118	1	POD-HPZ-000118	1	-----	---
9	Asymmetric tee 18 x 18 x 18 12L	24KT18/18/18	3	24KT18/18/18	3	-----	---
10*	Hydraulic hose Flexible, L=170 mm	AA/111/10 L=170	4	AA/111/10 L=170	4	-----	---
11*	Hydraulic hose Flexible, L=400 mm	AA90/111/10 L=400	1	AA90/111/10 L=400	1	-----	---
12*	Hydraulic hose Flexible, L=800 mm	AA90/111/10 L=800	1	AA90/111/10 L=800	1	-----	---
13*	Hydraulic hose Flexible, L=1050 mm	AA/111/10 L=1050	1	AA/111/10 L=1050	1	-----	---
14*	Hydraulic hose Flexible, L=3000 mm	AA90/111/10 L=3000	1	AA90/111/10 L=3000	1	-----	---
15*	Hydraulic hose Flexible, L=3600 mm	AA90/111/10 L=3600	1	AA90/111/10 L=3600	1	-----	---

#### 44. HYDRAULIC BRAKING SYSTEM (TANDEM)

The figure shows a fragment of the N267 spreader (8 tonnes)

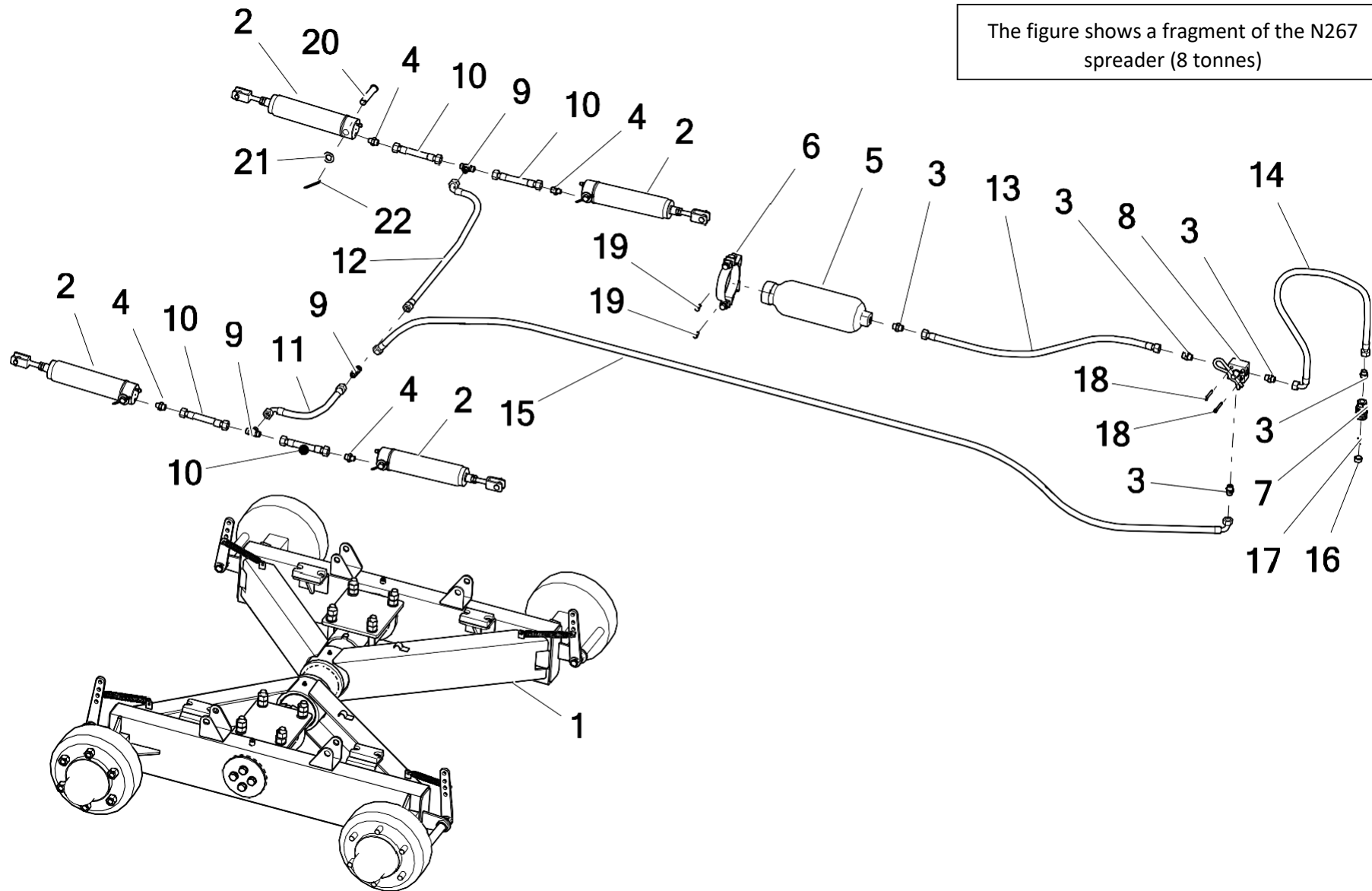



No.	Part or assembly name	Fig. or index No.					
		N267	Volume	N267/1	Volume	N267/2	Volume
16	Base for quick release coupling 900410		1		1	-----	---
17	Screw 6 x 20, galv. 82208	23W6/20OC	1	23W6/20OC	1	-----	---
18	Allen bolt 6 x 50 galv. 8.8 82302	POD-ELZ-000752	2	POD-ELZ-000752	2	-----	---
19	Bolt 8 x 20 galv. 82105 82105	23S8/20OC 8.8	2	23S8/20OC 8.8	2	-----	---
20	Cylinder pin	N267 18/01/2002	4	N267 18/01/2002	4	-----	---
21	Round washer 20OC 82005	23P20OOC	4	23P20OOC	4	-----	---
22	Cotter pin 5 x 63 galv.	23Z5/63	4	23Z5/63	4	-----	---

**Note:**

Items marked as **(\*)(10\* - 15\*)** are also available as **set No. 42**: 6-8t spreader with hydraulic brakes, under index No. **POD-HPR-000375**

Item **16** is included in the set with item **7** - **quick release coupling 900410 (21001462) - POD-PZ-000117**

**45. BRAKE VALVE, COMPLETE - HALDEX**

**HALDEX**

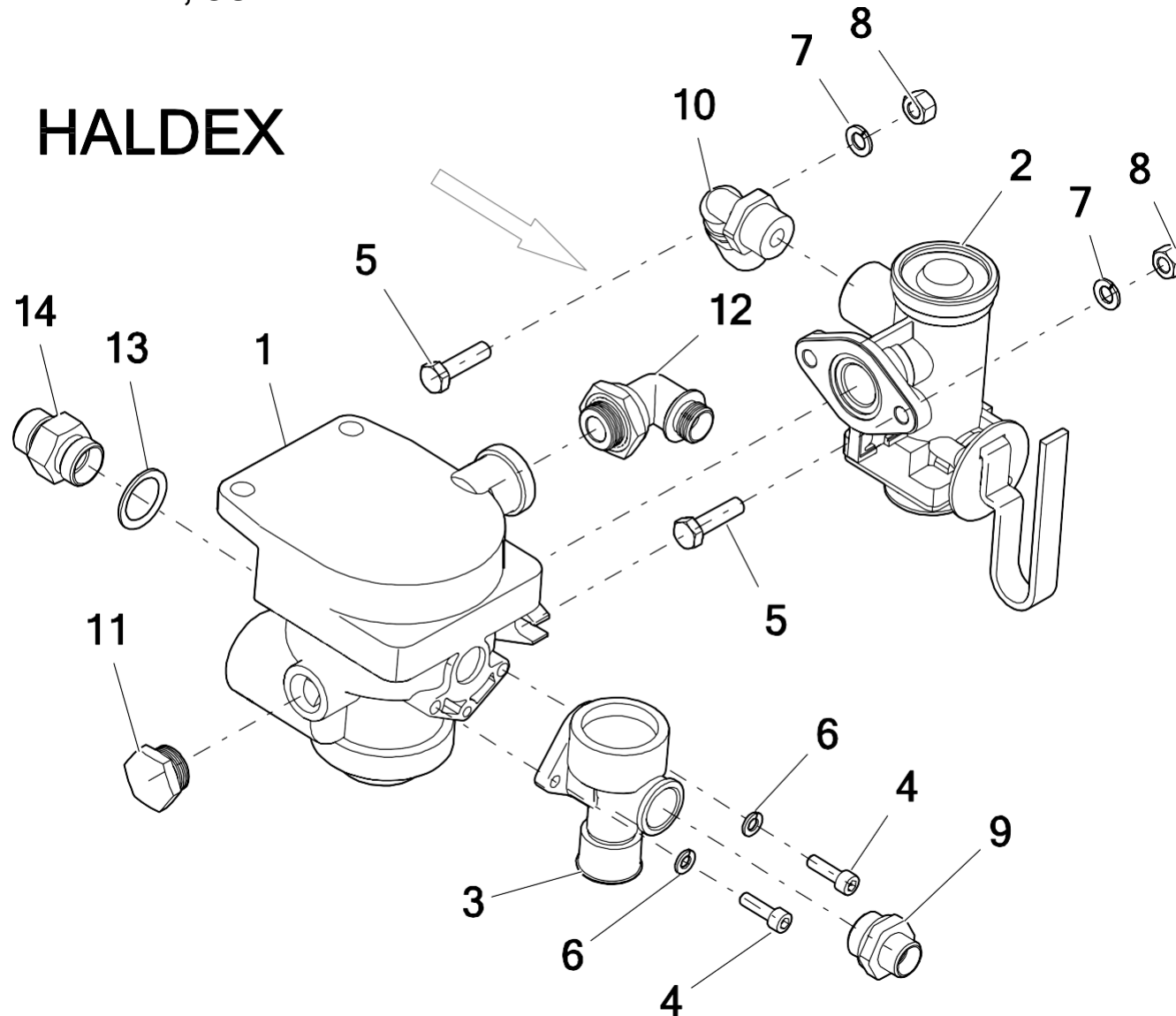

No.	Part or assembly name	Fig. or index No.					
		N267	Volume	N267/1	Volume	N267/2	Volume
1	Brake valve HALDEX	351008011	1	351008011	1	351008011	1
2	3-position manual braking force regulator HALDEX	POD-OGL-000564	1	POD-OGL-000564	1	POD-OGL-000564	1
3	Brake valve release 352 012 001 HALDEX	POD-OGL-001044	1	POD-OGL-001044	1	POD-OGL-001044	1
4	Allen bolt 6 x 20 galv. 8.8 82302	POD-ELZ-000759	2	POD-ELZ-000759	2	POD-ELZ-000759	2
5	Bolt 8 x 30 galv. 8.8 82105 82105	23S8/30OC 8.8	2	23S8/30 galv. 8.8	2	23S8/30 galv. 8.8	2
6	Spring washer 6.1 galv. 82008 82008	23P6SPOC	2	23P6SPOC	2	23P6SPOC	2
7	Spring washer 8.2 galv. 82008 82008	23P8SPOC	2	23P8SPOC	2	23P8SPOC	2
8	Nut M8 galv. 82144 5	23N8OC	2	23N8OC	2	23N8OC	2
9	Pneumatic straight connector M22-M16	POD-PZŁ-000010	1	POD-PZŁ-000010	1	POD-PZŁ-000010	1
10	Pneumatic elbow M22-12 x 1.5 TK12	POD-PZŁ-000016	1	POD-PZŁ-000016	1	POD-PZŁ-000016	1
11	Pneumatic plug M22	POD-PZŁ-000037	1	POD-PZŁ-000037	1	POD-PZŁ-000037	1
12	Pneumatic elbow M22-16 x 1.5	POD-PZŁ	1	POD-PZŁ	1	POD-PZŁ	1
13	Seal ring PPM22 30 x 22	24UPPM22	1	24UPPM22	1	24UPPM22	1
14	Connector	24K22-22	1	24K22-22	1	24K22-22	1

**46. BRAKE VALVE, COMPLETE - KNORR**

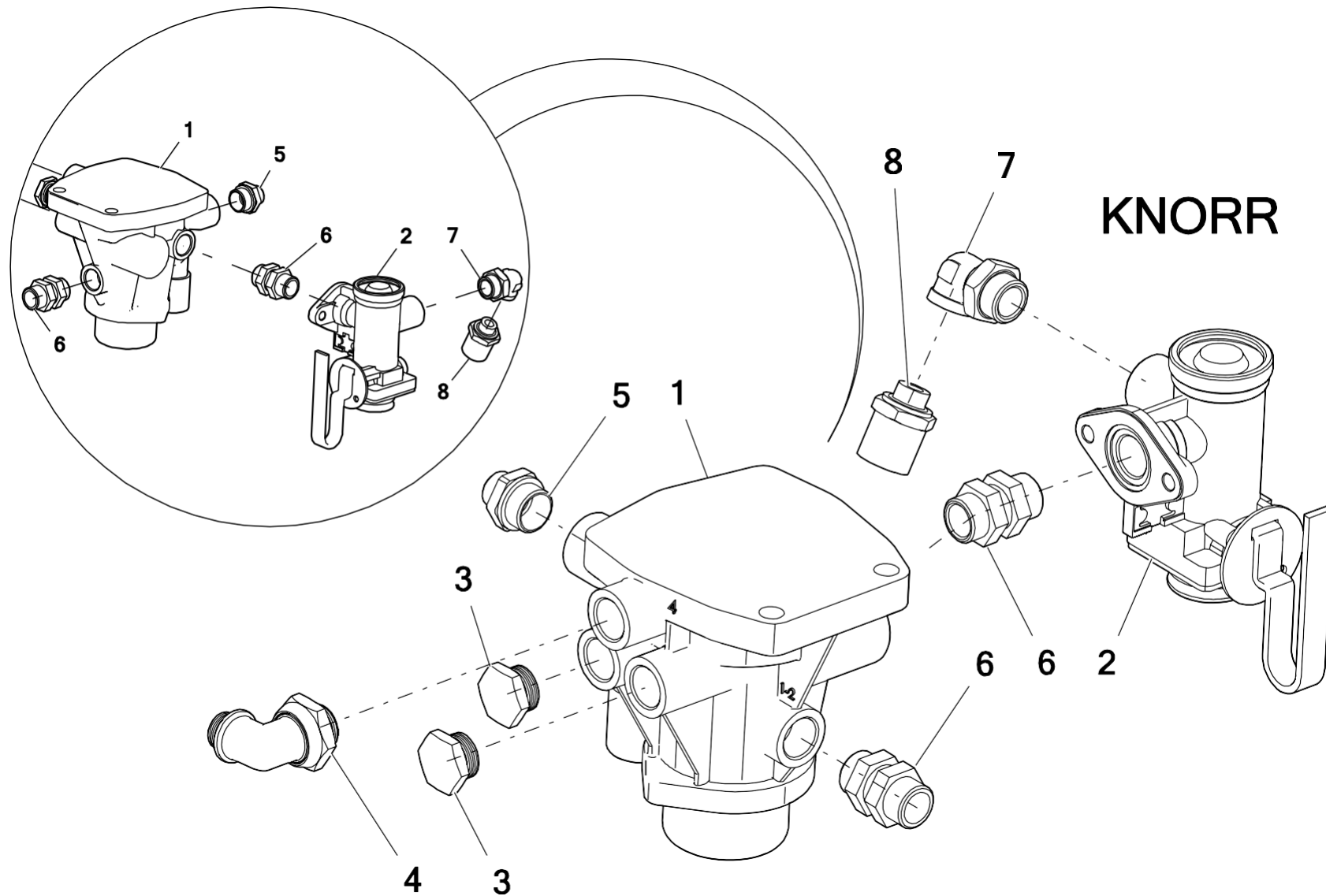

No.	Part or assembly name	Fig. or index No.					
		N267	Volume	N267/1	Volume	N267/2	Volume
1	Trailer brake valve with KNORR brake release	POD-OGL-000630	1	POD-OGL-000630	1	POD-OGL-000630	1
2	3-position manual braking force regulator KNORR	POD-OGL-000631	1	POD-OGL-000631	1	POD-OGL-000631	1
3	Pneumatic plug M22	POD-PZŁ-000037	2	POD-PZŁ-000037	2	POD-PZŁ-000037	2
4	Pneumatic elbow M22-18x1.5	POD-PZŁ	1	POD-PZŁ	1	POD-PZŁ	1
5	Straight pneumatic connector M22-M22	POD-PZŁ-000010	1	POD-PZŁ-000010	1	POD-PZŁ-000010	1
6	Bulkhead pneumatic coupling ext. M22/ext. M22/int. M16	POD-PZŁ-000086	2	POD-PZŁ-000086	2	POD-PZŁ-000086	2
7	Elbow connector M22-M16 for KNORR		1		1		1
8	Pneumatic connector M16 diam. 15		1		1		1

## 47. SUSPENSION TYPE - SPRINGS - PNEUMATIC BRAKES

The figure shows a fragment of the N267/2 spreader (10 tonnes)

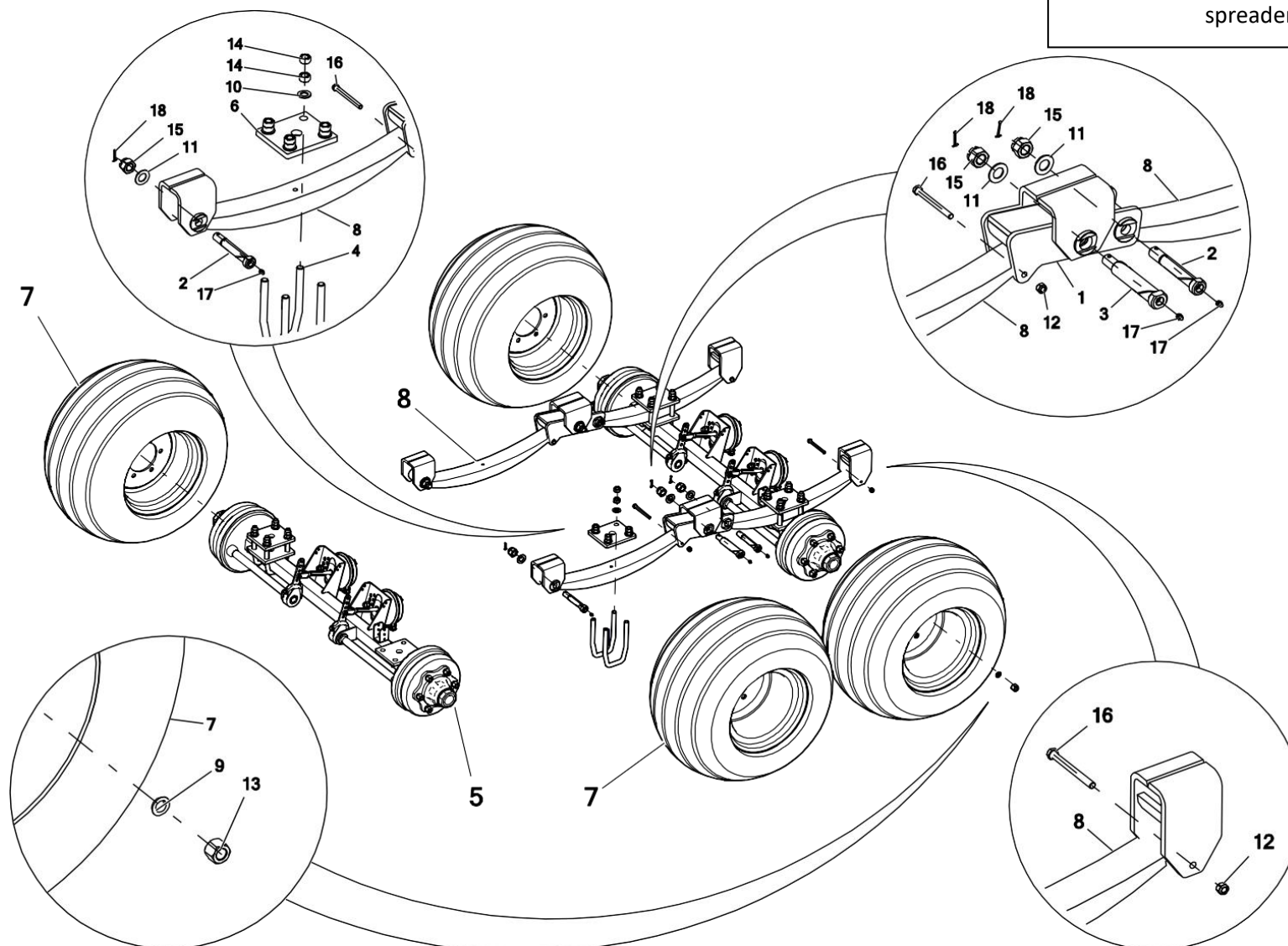

No.	Part or assembly name	Fig. or index No.					
		N267	Volume	N267/1	Volume	N267/2	Volume
1	Connector for suspension springs, complete	-----	---	-----	---	N280 01/10/2000	2
2	Leaf spring pin	-----	---	-----	---	N280 01/10/2007	4
3	Connector pin	-----	---	-----	---	N280 01/10/2008	2
4	U-bolt clamp for axle	-----	---	-----	---	N280 01.30.03	8
5	Axle, complete	-----	---	-----	---	N280 01.50.00.1	2
6	U-bolt plate	-----	---	-----	---	N280 01.50.01	4
7	Wheel 500/50-17 14PR	-----	---	-----	---	POD-KOL-000001-1	4
8	Suspension spring 13.13.000	-----	---	-----	---	POD-KOS-000075	4
9	Spring washer for 18 DIN 74361 wheels	-----	---	-----	---	POD-ELZ-000489	24
10	Round washer 20 galv. 82005	-----	---	-----	---	23P20OOC	16
11	Round washer 24 galv. 82005	-----	---	-----	---	23P24OC	6
12	Self-locking nut M12 galv. 82175 8 82175 8	-----	---	-----	---	23NS12OC	2
13	Wheel nut 18 x 1.5	-----	---	-----	---	POD-ELZ-000490	24
14	M20 x 1.5 Nut	-----	---	-----	---	23N20-1.5OC	32
15	Castellated nut M24 cl. 8 galv. 82148	-----	---	-----	---	POD-ELZ-000396	6
16	Bolt 12 x 120 galv. 8.8 82101	-----	---	-----	---	23S12/120OC	2
17	Lubricating nipple M10 x 1, straight	-----	---	-----	---	23SM10/1	6
18	Cotter pin 4 x 50 galv.	-----	---	-----	---	24Z4-50	6

### 48. SUSPENSION TYPE - TANDEM - PNEUMATIC BRAKES

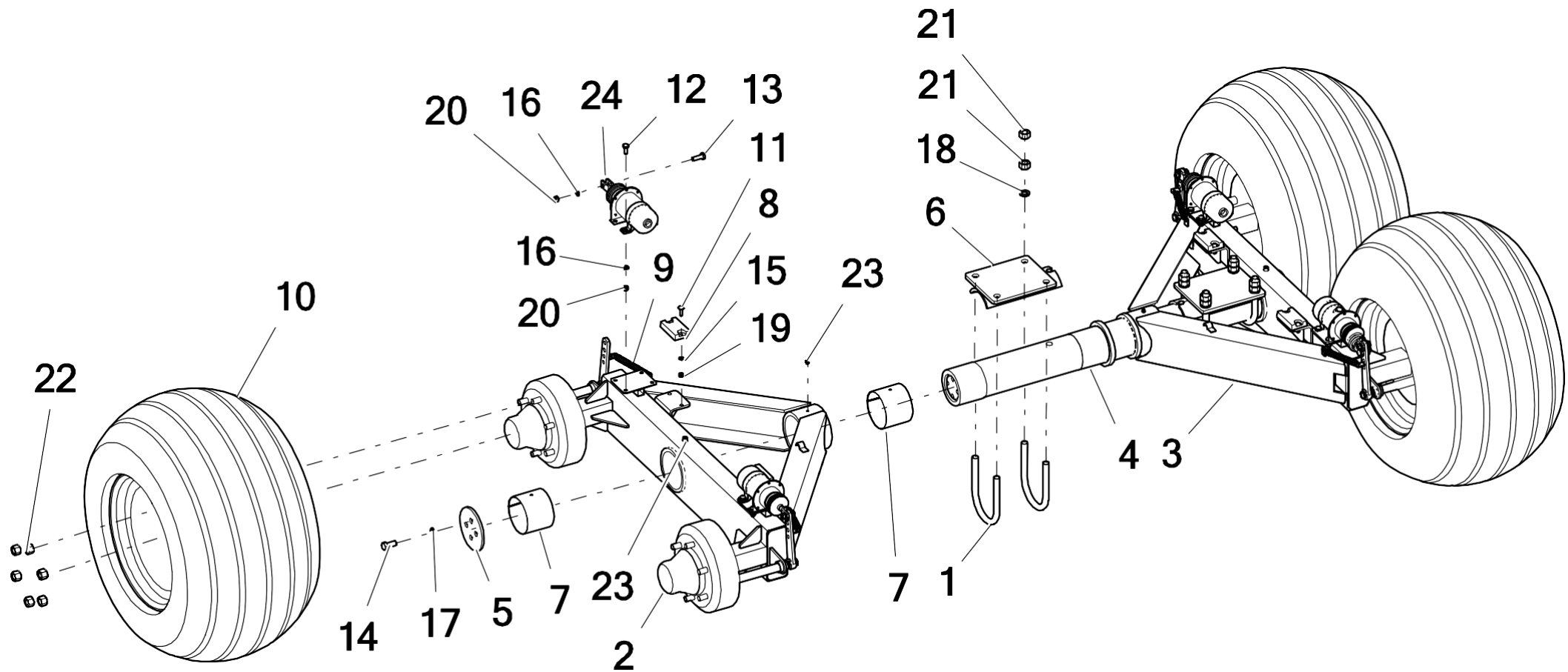

The figure shows a fragment of the N267 spreader  
(8 tonnes)



No.	Part or assembly name	Fig. or index No.					
		N267	Volume	N267/1	Volume	N267/2	Volume
1	U-bolt	N267 01.00.01	4	N267 01.00.01	4	-----	---
2	Right rocker	N267 01.01.00.1	1	N267 01.01.00.1	1	-----	---
3	Left rocker	N267 01.02.00.1	1	N267 01.02.00.1	1	-----	---
4	Tandem axis	N267 01/03/2000	1	N267 01/03/2000	1	-----	---
5	Tandem flange	N267 01/03/2004	2	N267 01/03/2004	2	-----	---
6	Axle cap	N267 01/05/2000	2	N267 01/05/2000	2	-----	---
7	Bushing	PAP125100P20	4	PAP125100P20	4	-----	---
8	Spacer rubber	POD-TSZ-000007-1	4	POD-TSZ-000007-1	4	-----	---
9	Tension spring	POD-SPR-000047	4	POD-SPR-000047	4	-----	---
10	Wheel 500/50-17 14 PR	500/50-17 14 PR	4	-----	---	-----	---
	Wheel 400/60-15.5 14 PR	-----	---	400/60-15.5 14 PR	4	-----	---
11	Bolt M8 x 30 (carriage)	23S8/30P	8	23S8/30P	8	-----	---
12	Bolt M10 x 25	23S10/25OC 8.8	16	23S10/25OC 8.8	16	-----	---
13	Bolt M10 x 40	23S10/40OC 8.8	4	23S10/40OC 8.8	4	-----	---
14	Bolt M16 x 35	23S16/35 8.8OC	4	23S16/35 8.8OC	4	-----	---
15	Spring washer Ø8	23P8SPOC	8	23P8SPOC	8	-----	---
16	Round washer Ø10	23P10 82005	20	23P10 82005	20	-----	---
17	Spring washer Ø16	23P16SP	4	23P16SP	4	-----	---

### 49. SUSPENSION TYPE - TANDEM - PNEUMATIC BRAKES

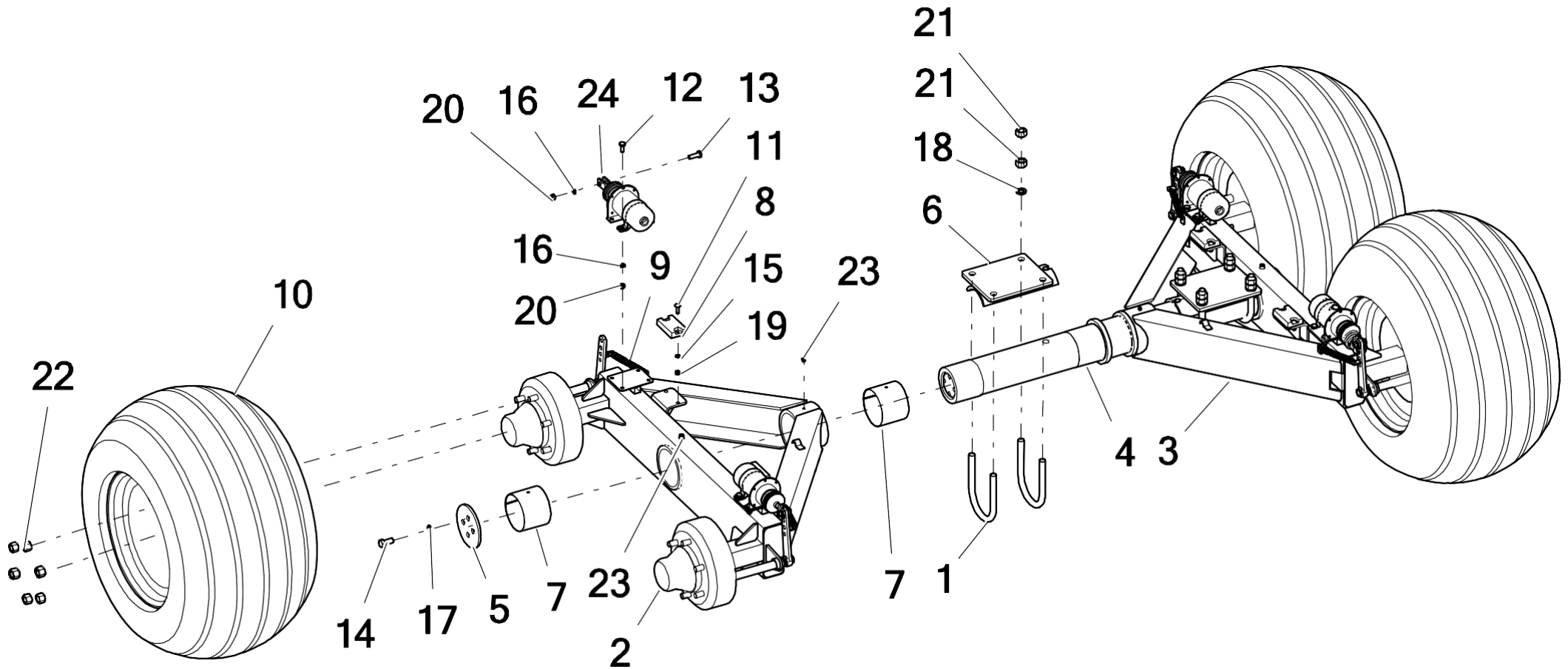

The figure shows a fragment of the N267 spreader (8 tonnes)

No.	Part or assembly name	Fig. or index No.					
		N267	Volume	N267/1	Volume	N267/2	Volume
18	Washer NORD-LOCK NL20 (20.4 x 30.7 x 3)	POD-ELZ-000472	16	POD-ELZ-000472	16	-----	---
19	Nut M8	23N8OC	8	23N8OC	8	-----	---
20	Nut M10	23N10OC	20	23N10OC	20	-----	---
21	Nut M20	23N20OC	8	23N20OC	8	-----	---
22	Nut M18 x 1.5 (for wheels)	complete with hub	24	complete with hub	24	-----	---
23	Lubricating nipple M10 x 1 (straight)	23SM10/1	4	23SM10/1	4	-----	---
24	Air cylinder 53.12.00/A	POD-OGL-000022-1	4	POD-OGL-000022-1	4	-----	---

### 50. SUSPENSION TYPE - TANDEM - HYDRAULIC BRAKES

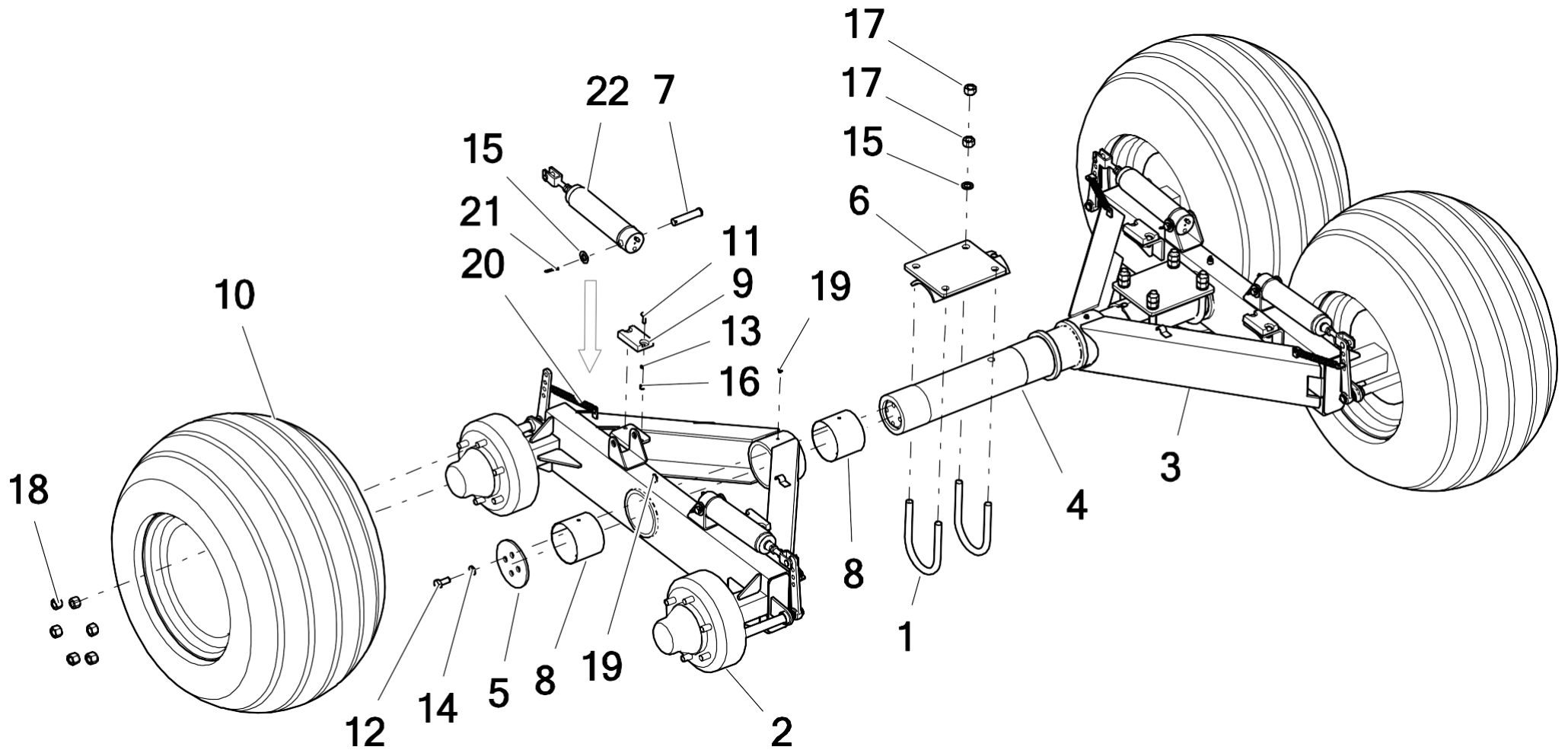

The figure shows a fragment of the N267 spreader (8 tonnes)

No.	Part or assembly name	Fig. or index No.					
		N267	Volume	N267/1	Volume	N267/2	Volume
1	U-bolt	N267 01.00.01	4	N267 01.00.01	4	-----	---
2	Right rocker	N267 18/10/2000	1	N267 18/10/2000	1	-----	---
3	Left rocker	N267 18.20.00	1	N267 18.20.00	1	-----	---
4	Tandem axis	N267 01.03.00.1	1	N267 01.03.00.1	1	-----	---
5	Tandem flange II	N267 01.03.04.1	2	N267 01.03.04.1	2	-----	---
6	Axle cap	N267 01/05/2000	2	N267 01/05/2000	2	-----	---
7	Pin	N267 18/01/2002	4	N267 18/01/2002		-----	---
8	Bushing PAP125100P20	POD-LOZ-000017-1	4	POD-LOZ-000017-1	4	-----	---
9	Spacer rubber	POD-TSZ-000007-1	4	POD-TSZ-000007-1	4	-----	---
10	Wheel 500/50-17 14 PR	500/50-17 14 PR	4	-----	---	-----	---
	Wheel 400/60-15.5 14 PR	-----	---	400/60-15.5 14 PR	4	-----	---
11	Bolt M8 x 30 (carriage)	23S8/30P	8	23S8/30P	8	-----	---
12	Bolt M16 x 35	23S16/35 8.8OC	4	23S16/35 8.8OC	4	-----	---
13	Spring washer Ø8	23P8SPOC	8	23P8SPOC	8	-----	---
14	Spring washer Ø16	23P16SP	4	23P16SP	4	-----	---
15	Spring washer Ø20	23P20OOC	16	23P20OOC	16	-----	---
16	Nut M8	23N8OC	8	23N8OC	8	-----	---
17	Nut M20	23N20OC	16	23N20OC	16	-----	---

### 51. SUSPENSION TYPE - TANDEM - HYDRAULIC BRAKES

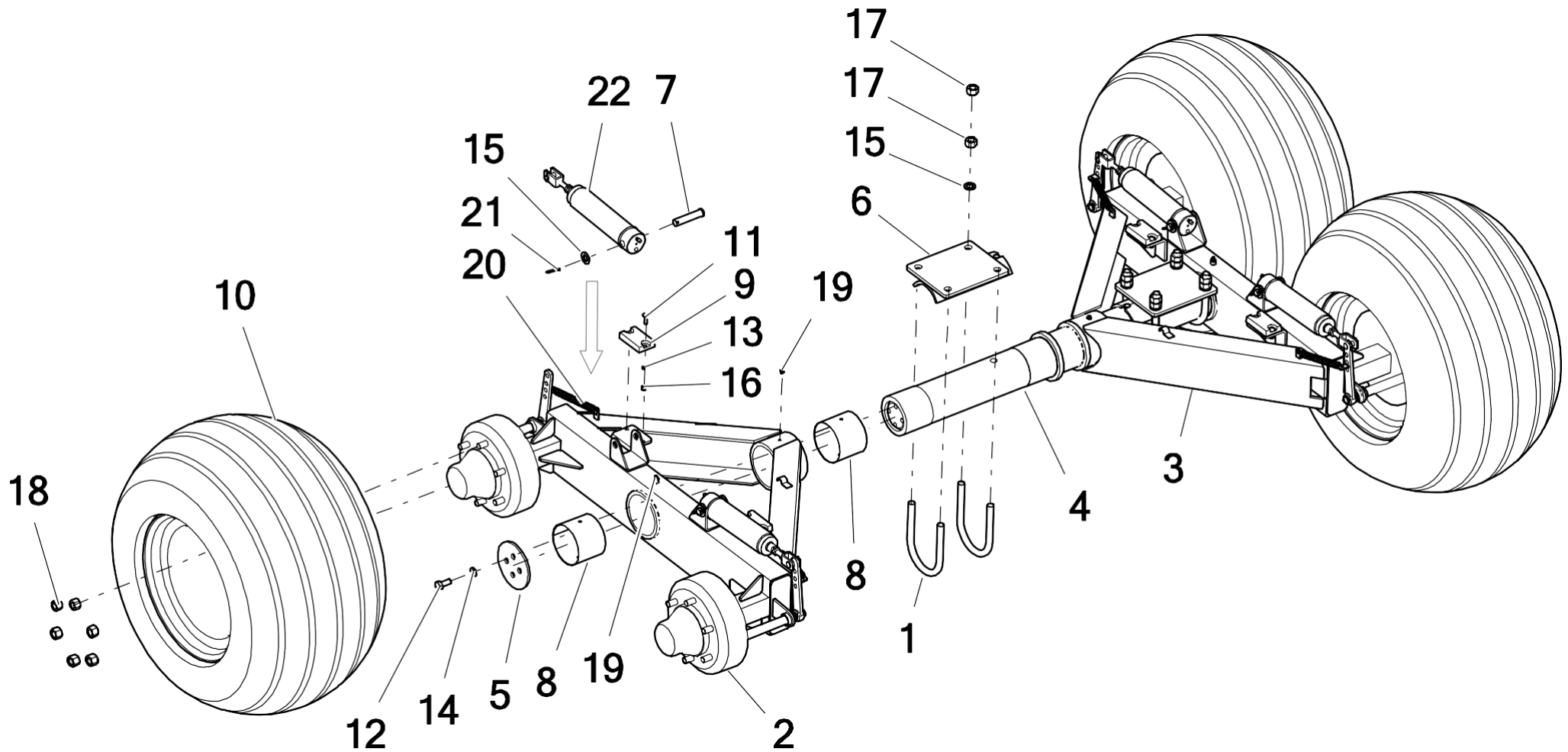

The figure shows a fragment of the N267 spreader (8 tonnes)

No.	Part or assembly name	Fig. or index No.					
		N267	Volume	N267/1	Volume	N267/2	Volume
18	Nut M18 x 1.5 (for wheels)	complete with hub	24	complete with hub	24	-----	---
19	Lubricating nipple M10 x 1 (straight)	23SM10/1	4	23SM10/1	4	-----	---
20	Tension spring	POD-SPR-000047	4	POD-SPR-000047	4	-----	---
21	Cotter pin 5 x 63 galv.	23Z5/63	4	23Z5/63	4	-----	---
22	Brakes - actuator 900408 (21001460)	POD-HPZ-000112	4	POD-HPZ-000112	4	-----	---

## 52. HANDBRAKE, COMPLETE (N267/2)

The figure shows a fragment of the N267/2 spreader (10 tonnes)

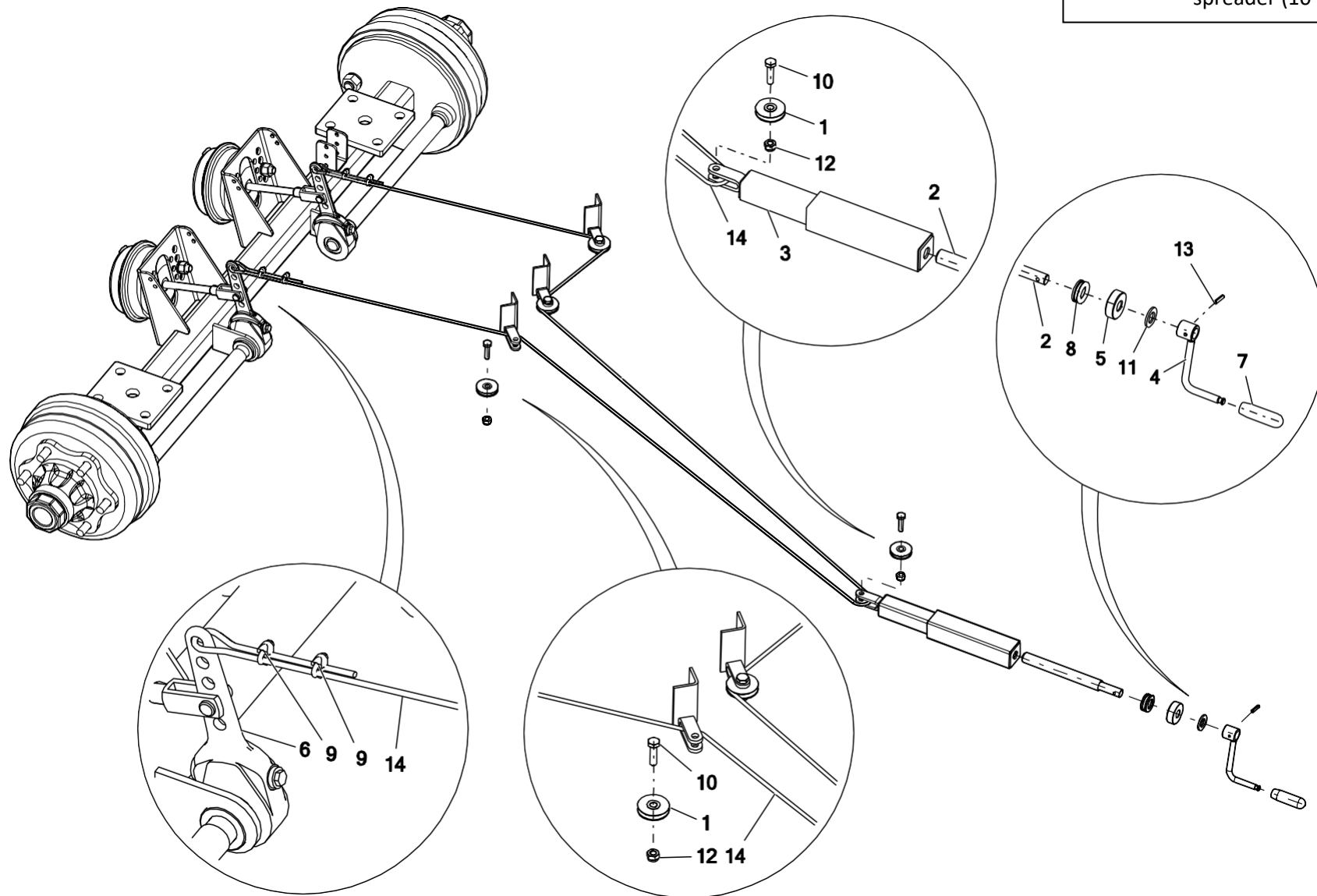



No.	Part or assembly name	Fig. or index No.					
		N267	Volume	N267/1	Volume	N267/2	Volume
1	Line pulley	N267 02/01/2026	4	N267 02/01/2026	3	N267 02/01/2026	4
2	Screw	N267 02.01.33.1	1	N267 02.01.33.1	1	N267 02.01.33.1	1
3	Tensioning slide	N267 02/01/2034	1	N267 02/01/2034	1	N267 02/01/2034	1
4	Tensioning crank	N267 02/01/2037	1	N267 02/01/2037	1	N267 02/01/2037	1
5	Bearing guard	N267 02/01/2044	1	N267 02/01/2044	1	N267 02/01/2044	1
6	Axle, complete	N280 01.50.00.1	1	N280 01.50.00.1	1	N280 01.50.00.1	1
7	Handle holder	Z560 02.37.03-N267	1	Z560 02.37.03-N267	1	Z560 02.37.03-N267	1
8	51204 bearing	25K51204	1	25K51204	1	25K51204	1
9	Cable clamp 6 mm	23ZL6	4	23ZL6	3	23ZL6	4
10	Bolt 10 x 40 galv. 8.8 82101	POD-ELZ-000045-1	4	POD-ELZ-000045-1	3	POD-ELZ-000045-1	4
11	Round washer 20 galv. 82005	23P20OOC	1	23P20OOC	1	23P20OOC	1
12	Self-locking nut M10 galv. 8.8 82175	23NS10OC	4	23NS10OC	3	23NS10OC	4
13	Spring pin 6 x 30 DIN 1481	23K6/30	1	23K6/30	1	23K6/30	1
14	Steel cable 5 mm, L~5 m	23LS5	1	23LS5	1	23LS5	1

### 53. VERTICAL ADAPTOR, COMPLETE

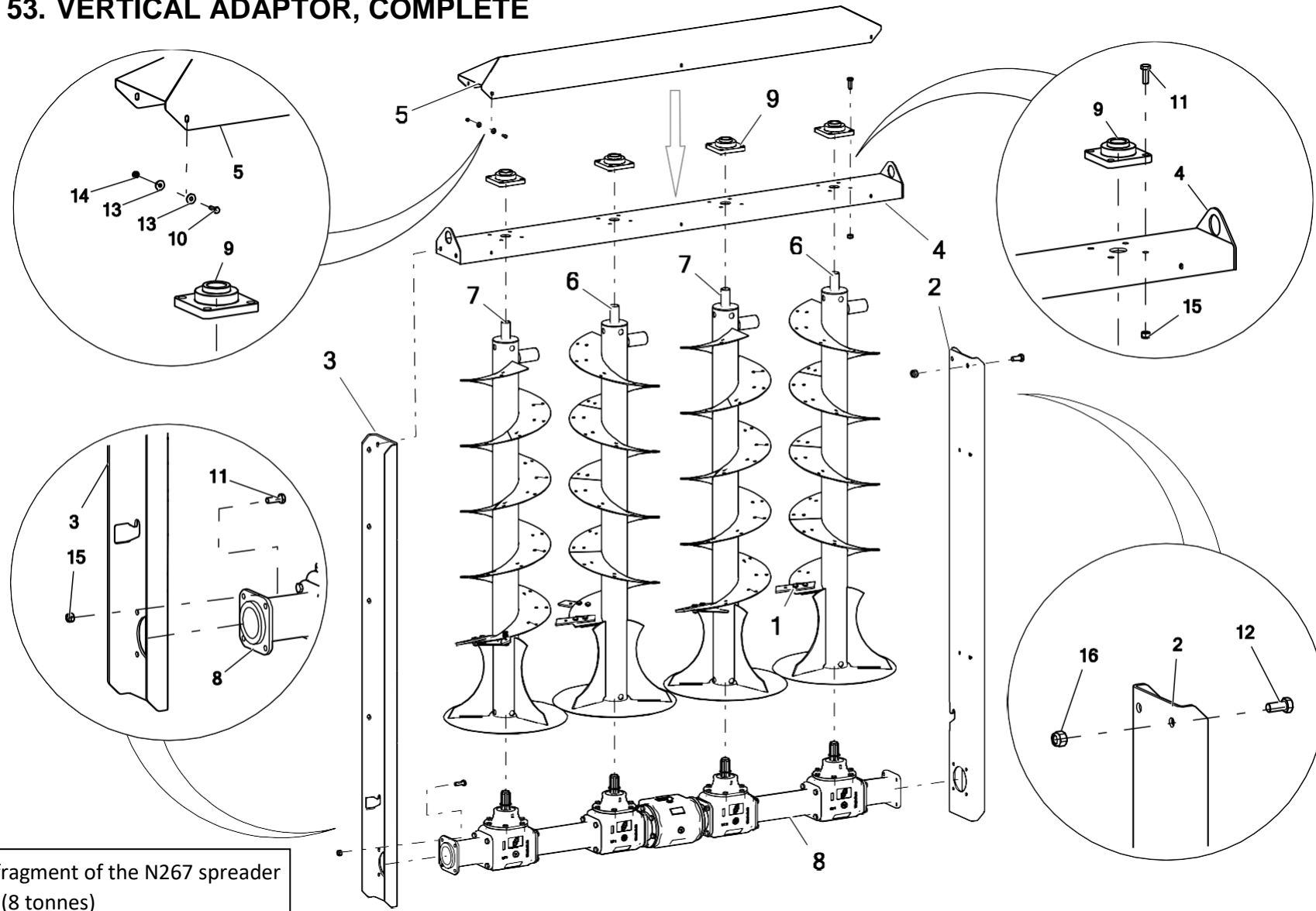

The figure shows a fragment of the N267 spreader  
(8 tonnes)

No.	Part or assembly name	Fig. or index No.					
		N267	Volume	N267/1	Volume	N267/2	Volume
1	Auger blade	N267 09.00.07.2	128	N267 09.00.07.2	96	N267 09.00.07.2	128
2	Right adapter frame	N267 09.03.01.1	1	N267-1 09.03.01.1	1	N267 09.03.01.1	1
3	Left adapter frame	N267 09.04.01.1	1	N267-1 09.04.01.1	1	N267 09.04.01.1	1
4	Upper adapter frame	N267 09.05.00.1	1	N267 09.05.00.1	1	N267 09.05.00.1	1
5	Upper guard, complete	N267 09.08.00	1	N267 09.08.00	1	N267 09.08.00	1
6	Left auger	N267 09.10.00	2	N267-1 09.10.00	2	N267 09.10.00	2
7	Right auger	N267 09.20.00	2	N267-1 09.20.00	2	N267 09.20.00	2
8	Gearbox, complete PRK-051-01.1AAAA.R1.	POD-WPS-000208	1	POD-WPS-000208	1	POD-WPS-000208	1
9	Bearing unit UCF207	POD-LOZ-000101	4	POD-LOZ-000101	4	POD-LOZ-000101	4
10	Bolt 6 x 20 galv. 8.8 82105	23S6/20	6	23S6/20	6	23S6/20	6
11	Bolt 12 x 35 galv. 8.8 82105	23S12/35OC 8	24	23S12/35OC 8	24	23S12/35OC 8	24
12	Bolt 16 x 35 galv. 8.8 82105	23S16/35 8.8OC	4	23S16/35 8.8OC	4	23S16/35 8.8OC	4
13	Round washer 6 galv. coated 82030	23P6OC030	12	23P6OC030	12	23P6OC030	12
14	Self-locking nut M6 galv. 82175 8 82175 8	23NS6OC	6	23NS6OC	6	23NS6OC	6
15	Self-locking nut M12 galv. 82175 8 82175 8	23NS12OC	24	23NS12OC	24	23NS12OC	24
16	Self-locking nut M6 galv. 82175 8 82175 8	23NS16OC	4	23NS16OC	4	23NS16OC	4

### 54. LEFT AUGER, COMPLETE

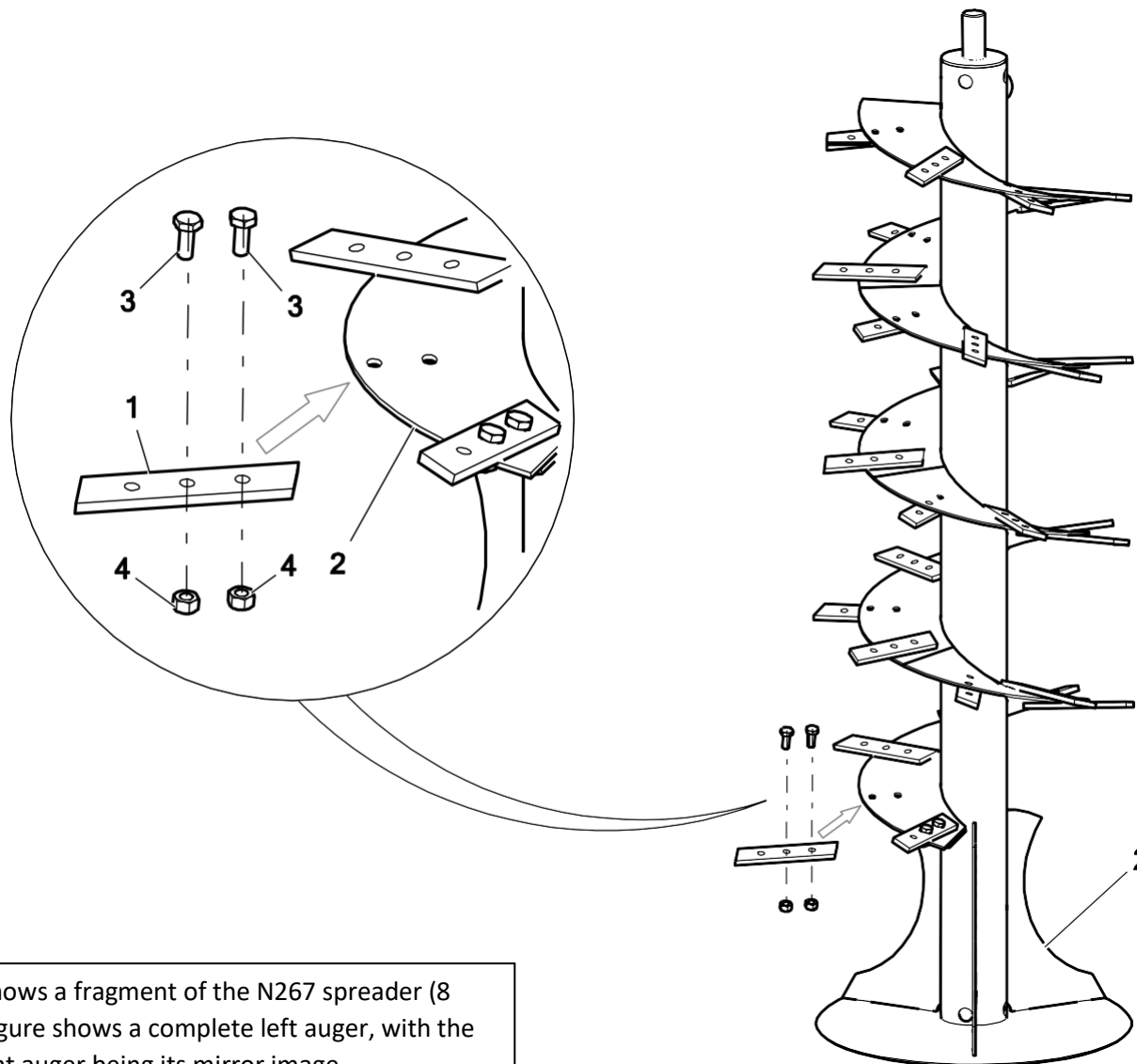

The figure shows a fragment of the N267 spreader (8 tonnes). The figure shows a complete left auger, with the right auger being its mirror image.

No.	Part or assembly name	Fig. or index No.					
		N267	Volume	N267/1	Volume	N267/2	Volume
1	Auger blade	N267 09.00.07.2	32	N267 09.00.07.2	24	N267 09.00.07.2	32
2	Left auger	N267 09/10/2000	1	N267-1 09/10/2000	1	N267 09/10/2000	1
3	Bolt 10 x 25 galv. 8.8 82105	23S10/25OC 8	64	23S10/25OC 8	48	23S10/25OC 8	64
4	Nut M10 galv. 82144 5	23N10OC	64	23N10OC	48	23N10OC	64

## 55. NET LIFTING MECHANISM, COMPLETE

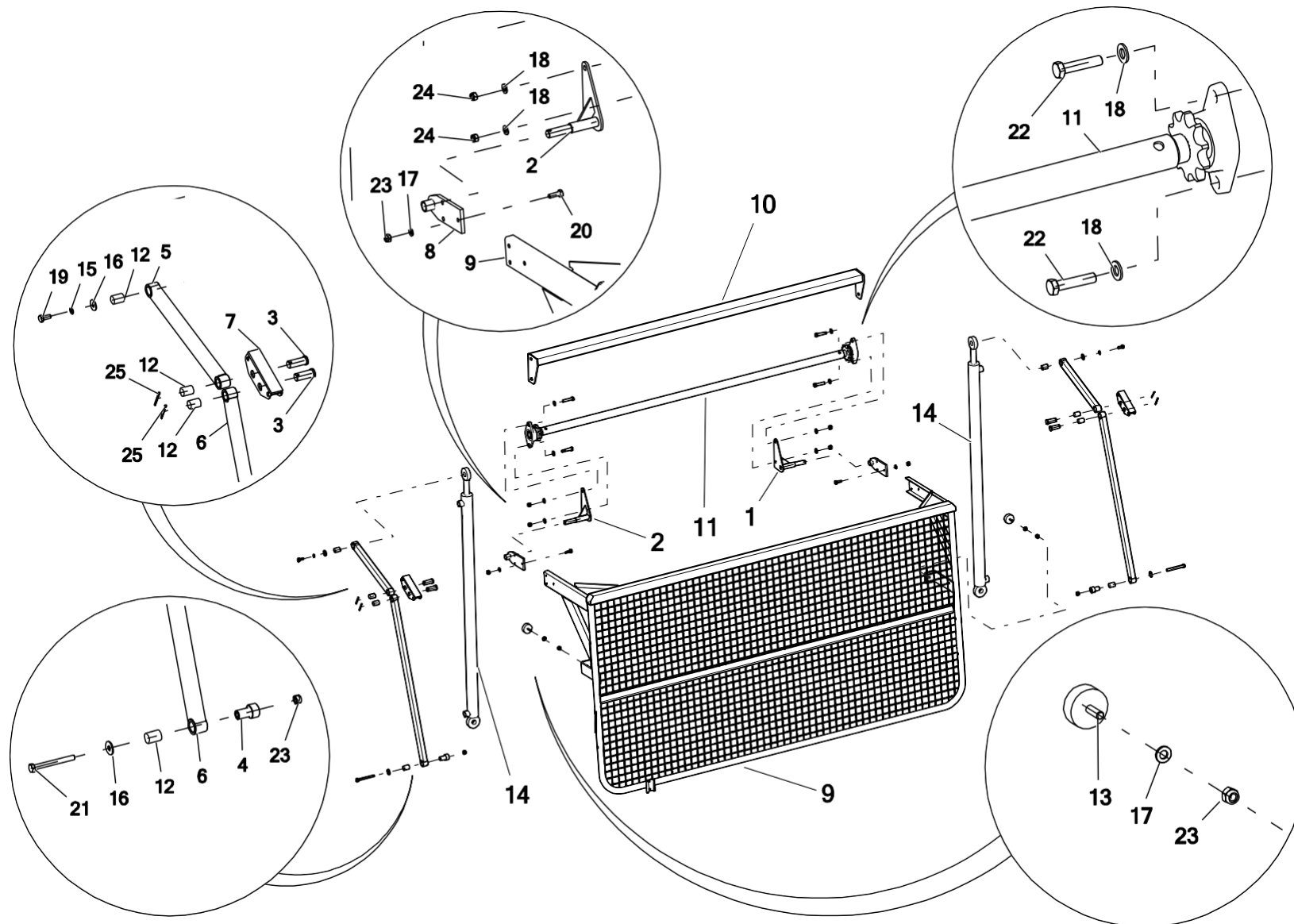

No.	Part or assembly name	Fig. or index No.					
		N267	Volume	N267/1	Volume	N267/2	Volume
1	Right net support	N267 06/10/2000	1	N267 06/10/2000	1	N267 06/10/2000	1
2	Left net support	N267 06.20.00	1	N267 06.20.00	1	N267 06.20.00	1
3	Pin for net supporting arms	N267 10.00.20	4	N267 10.00.20	4	N267 10.00.20	4
4	Sleeve for net supporting arm	N267 10.00.21	2	N267 10.00.21	2	N267 10.00.21	2
5	Short supporting arm for net	N267 10.04.2000	2	N267 10.04.2000	2	N267 10.04.2000	2
6	Long supporting arm for net	N267 10/05/2000	2	N267 10/05/2000	2	N267 10/05/2000	2
7	Hinge for arms	N267 10/06/2000	2	N267 10/06/2000	2	N267 10/06/2000	2
8	Hinge for rear net	N280 07/02/2000	2	N280 07/02/2000	2	N280 07/02/2000	2
9	Rear net	N280 07.01.00.2	1	N280 07.01.00.2	1	N280 07.01.00.2	1
10	Bracing for panels, complete	N267 13.00.00	1	N267 13.00.00	1	N267 13.00.00	1
11	Synchronizer, complete	N267 14.00.00	1	N267 14.00.00	1	N267 14/01/2000	1
12	Sleeve PAP 2030 P10	POD-LOZ-000022-1	8	POD-LOZ-000022-1	8	POD-LOZ-000022-1	8
13	Rubber bumper 50 x 18 M10	POD-TSZ-000107	2	POD-TSZ-000107	2	POD-TSZ-0001-7	2
14	Cylinder USJ2F-50/28/1200 L-1377	POD-HSL-000027-1	2	POD-HSL-000027-1	2	POD-HSL-000027-1	2
15	Spring washer 10.2 galv. 82008	23P10SP	2	23P10SP	2	23P10SP	2
16	Round washer 10 galv. coated 82030	23P10OC030	4	23P10OC030	4	23P10OC030	4
17	Round washer 10 galv. 82005	23P10 82005	4	23P10 82005	4	23P10 82005	4
18	Round washer 12 galv. 82005	23P12OC	8	23P12OC	8	23P12OC	8

## 56. NET LIFTING MECHANISM, COMPLETE

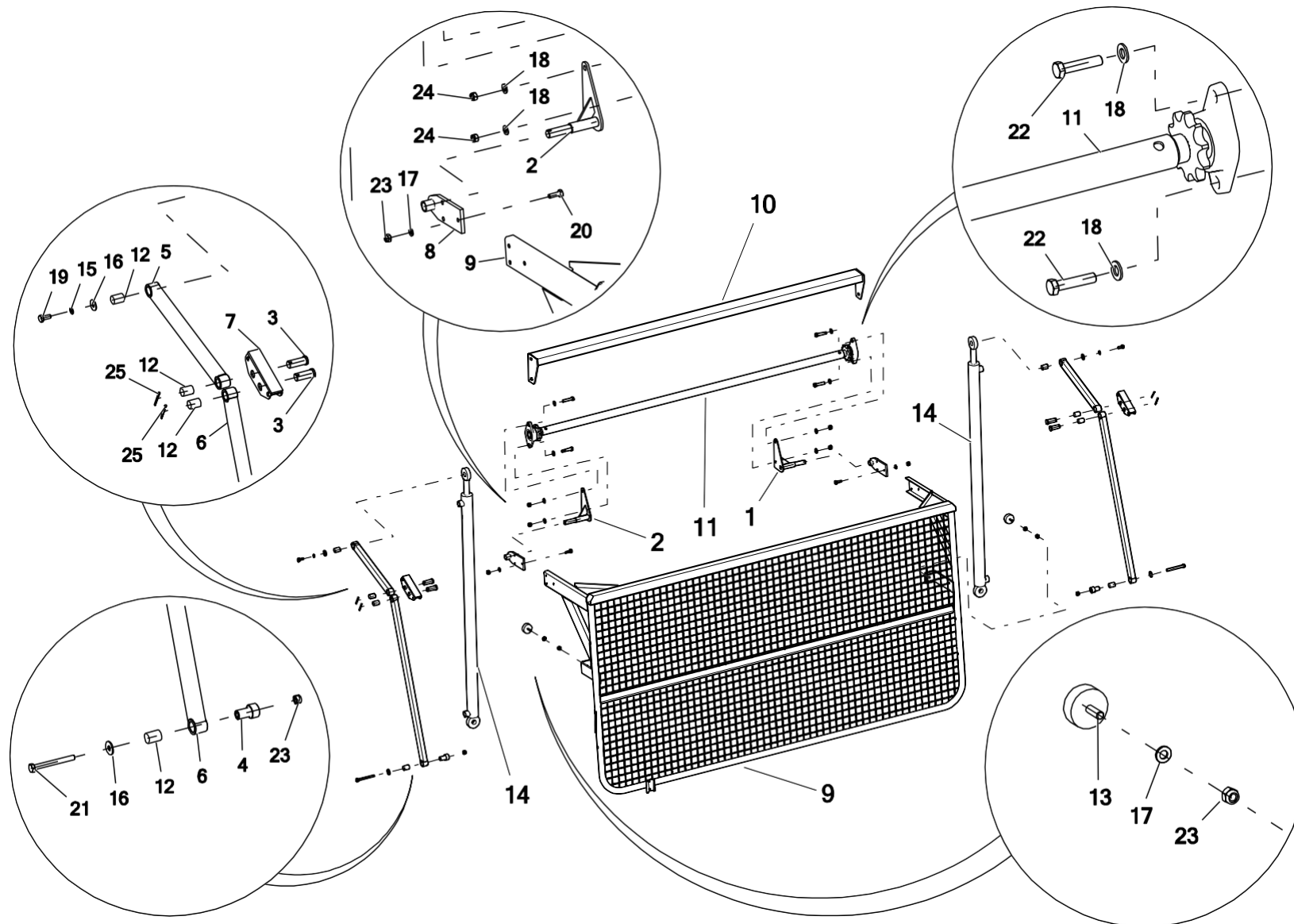



No.	Part or assembly name	Fig. or index No.					
		N267	Volume	N267/1	Volume	N267/2	Volume
19	Bolt 10 x 25 galv. 8.8 82105	23S10/25OC 8	2	23S10/25OC 8	2	23S10/25OC 8	2
20	Bolt 14 x 25 galv. 8.8 82105	23S10/30/OC 8	6	23S10/30/OC 8	6	23S10/30 galv. 8	6
21	Bolt 10 x 100 galv. 8.8 82101	23S10/100OC	2	23S10/100OC	2	23S10/100OC	2
22	Bolt 12 x 55 galv. 8.8 82105	POD-ELZ-000424	4	POD-ELZ-000424	4	POD-ELZ-000424	4
23	Self-locking nut M10 galv. 8.8 82175	23NS10OC	6	23NS10OC	6	23NS10OC	6
24	Self-locking nut M12 galv. 8.8 82175	23NS12OC	4	23NS12OC	4	23NS12OC	4
25	Cotter pin 4 x 50 galv.	23Z4/50	4	23Z4/50	4	23Z4/50	4

**57. GATE VALVE, COMPLETE**

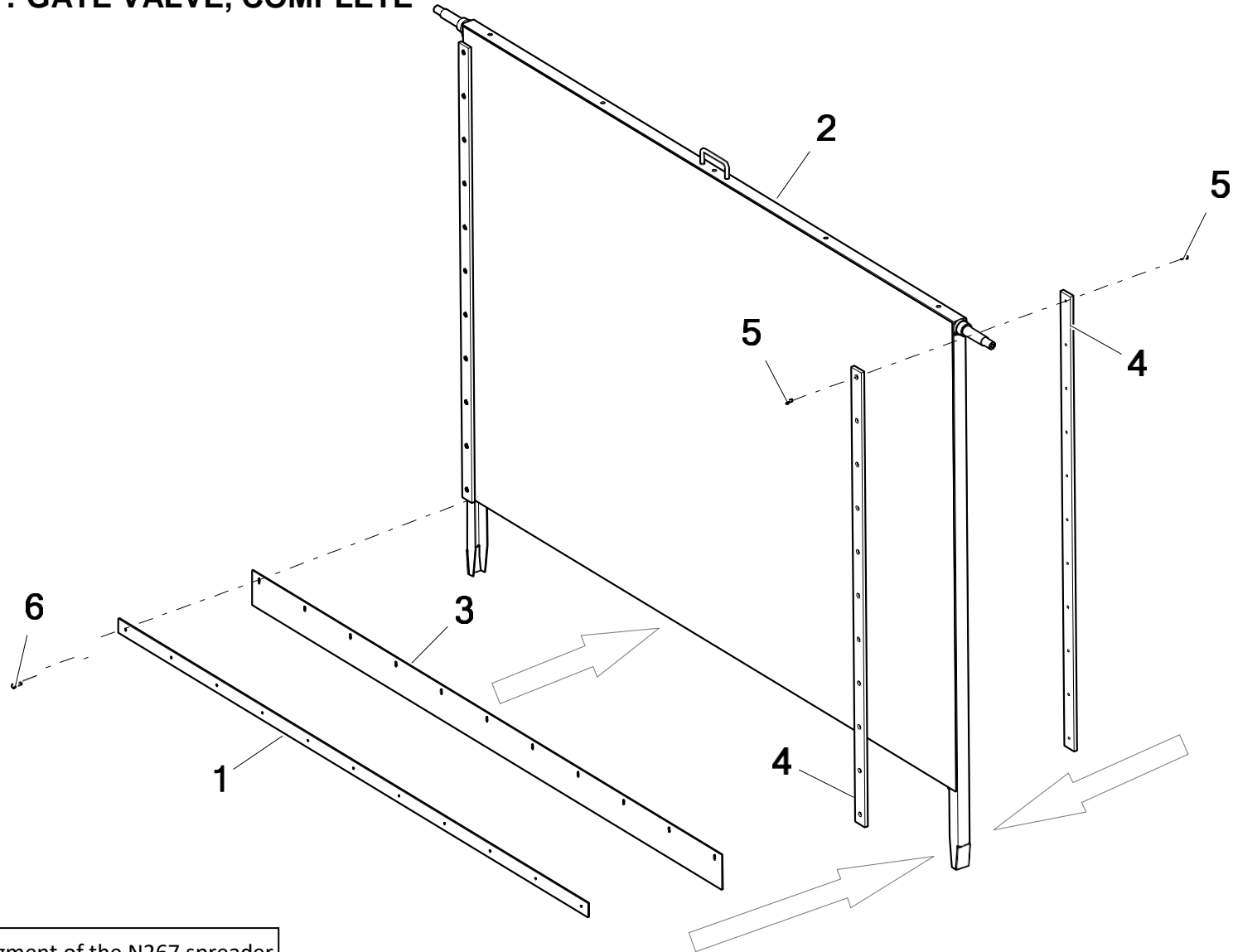

The figure shows a fragment of the N267 spreader  
(8 tonnes)

No.	Part or assembly name	Fig. or index No.					
		N267	Volume	N267/1	Volume	N267/2	Volume
1	Rubber mounting	N267 03.00.06	1	N267 03.00.06	1	N267 03.00.06	1
2	Rear gate valve, complete	N267 10.00.00.3	1	N267-1 10.00.00.3	1	N267 10.00.00.3	1
3	Rubber belt 2000 x 100 mm	POD-TSZ-000056	1	POD-TSZ-000056	1	POD-TSZ-000056	1
4	Tecamide slide L=1300 mm L=1300 mm (N267 10.00.06)	POD-TSZ-000060	4	-----	---	POD-TSZ-000060	4
	Tecamide slide L=1100 mm L=1300 mm (N267-1 10.00.06)	-----	---	POD-TSZ-000061	4	-----	---
5	Screw 6 x 16 galv. 82208	23W6/16	22	23W6/16	14	23W6/16	22
6	Bolt 6 x 20 galv. 8.8 82105	23S6/20	11	23S6/20	7	23S/20	11

**58. REAR SCRAPER FOR REAR ROLLER CHAIN WHEELS AND LUBRICATION**

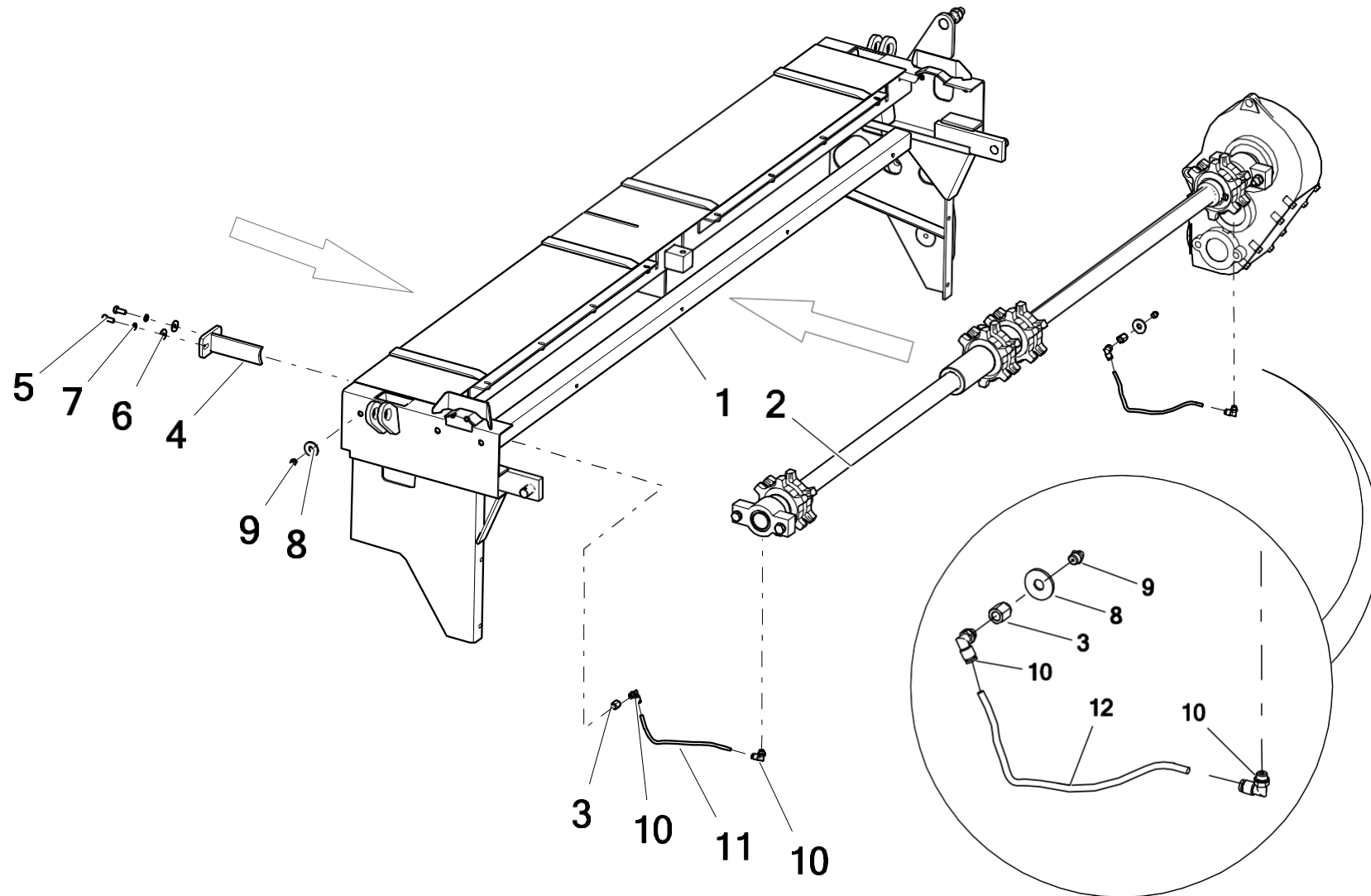

No.	Part or assembly name	Fig. or index No.					
		N267	Volume	N267/1	Volume	N267/2	Volume
1	Top frame	N267 02.02.00.2	1	N267 02.02.00.2	1	N267 02.02.00.2	1
2	Rear drive shaft, complete	N267 02.02.100.1	1	N267 02.02.100.1	1	N267 02.02.100.1	1
3	Connector	N267 02.02.114	2	N267 02.02.114	2	N267 02.02.114	2
4	Rear scraper	N267 02.02.120	4	N267 02.02.120	4	N267 02.02.120	4
5	Bolt 8 x 20 galv. 8.8 82105 82105	23S8/20OC 8.8	8	23S8/20OC 8.8	8	23S8/20OC 8.8	8
6	Round washer 8 galv. coated 82030	23P8OC 82030	8	23P8OC 82030	8	23P8OC 82030	8
7	Spring washer 8.2 galv. 82008 82008	23P8SPOC	8	23P8SPOC	8	23P8SPOC	8
8	Round washer 10 galv. coated 82030 82030	23P10 OC030	2	23P10 OC030	2	23P10 OC030	2
9	Lubricating nipple M10 x 1.0 straight	23SM10/1	2	23SM10/1	2	23SM10/1	2
10	Connector 6520-6-1/8 (RL31/C FOX6 1/8)	POD-HKR-000013-1	4	POD-HKR-000013-1	4	POD-HKR-000013-1	4
11	Central lubrication nipple Plastic conduit diam. 6 x 4 PA6	24P6	1	24P6	1	24P6	1
12	Central lubrication nipple Plastic conduit diam. 6 x 4 PA6	24P6	1	24P6	1	24P6	1

**59. ELECTRIC SYSTEM**

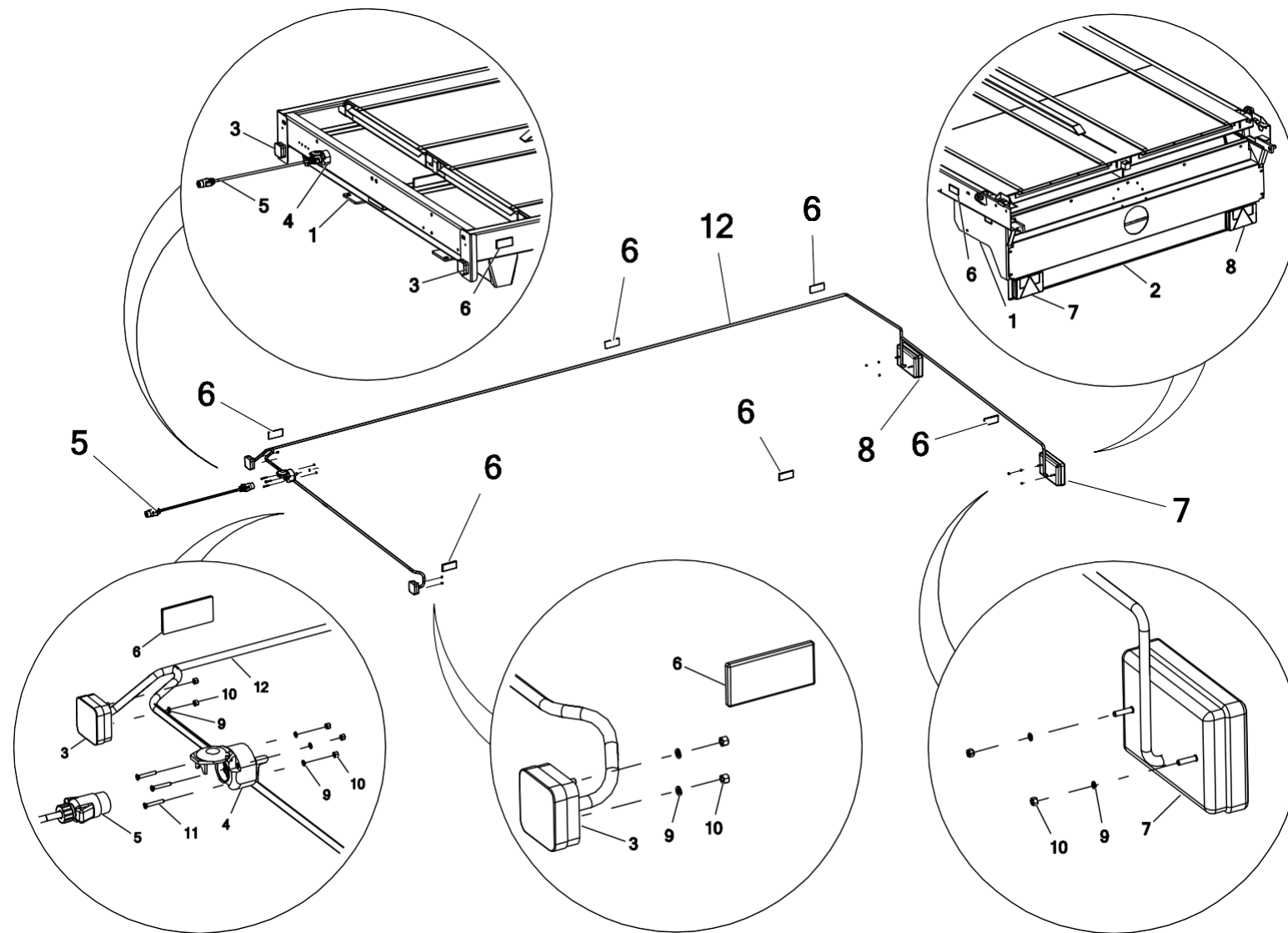

No.	Part or assembly name	Fig. or index No.					
		N267	Volume	N267/1	Volume	N267/2	Volume
1	Top frame	N267 02.02.00.2	1	N267 02.02.00.2	1	N267 02.02.00.2	1
2	Lower guard	N267 02.02.13.6	1	N267 02.02.13.6	1	N267 02.02.13.6	1
3	Square marker lamp with reflector LO 093	POD-ELK-000011-1	2	POD-ELK-000011-1	2	POD-ELK-000011-1	2
4	7-pin electric socket	POD-ELK-000033	1	POD-ELK-000034	1	POD-ELK-000033	1
5	7-pin connecting cable	POD-ELK-000033	1	POD-ELK-000034	1	POD-ELK-000033	1
6	Self-adhesive rectangular reflector 4.5 x 9.5 UO 030	POD-OGL-000019-1	6	POD-OGL-000019-1	4	POD-OGL-000019-1	6
7	Triple lamp cluster HOR45-LZT471, left	POD-ELK-000012-1	1	POD-ELK-000012-1	1	POD-ELK-000012-1	1
8	Triple lamp cluster HOR45-LZT478, right	POD-ELK-000013-1	1	POD-ELK-000013-1	1	POD-ELK-000013-1	1
9	Spring washer 5.1, galv. 82008	23P5,1SPOC	4	23P5,1SPOC	4	23P5,1SPOC	4
10	Nut M5 galv. 82144 5 82144	23N5OC	5	23N5OC	5	23N5OC	5
11	Screw 5 x 35 galv.	23W5/35	3	23W5/35	3	23W5/35	3
12	Electric bundle, complete	POD-ELK-000033	1	POD-ELK-000034	1	POD-ELK-000033	1

**Key:**

**No. 4, 5, - included in: Electric bundle, complete, for N267 and N267/2 - POD-ELK-000033, for N267/1 - POD-ELK-000034**

## 60. DEFLECTOR (SPREAD-LIMITING SCREEN)

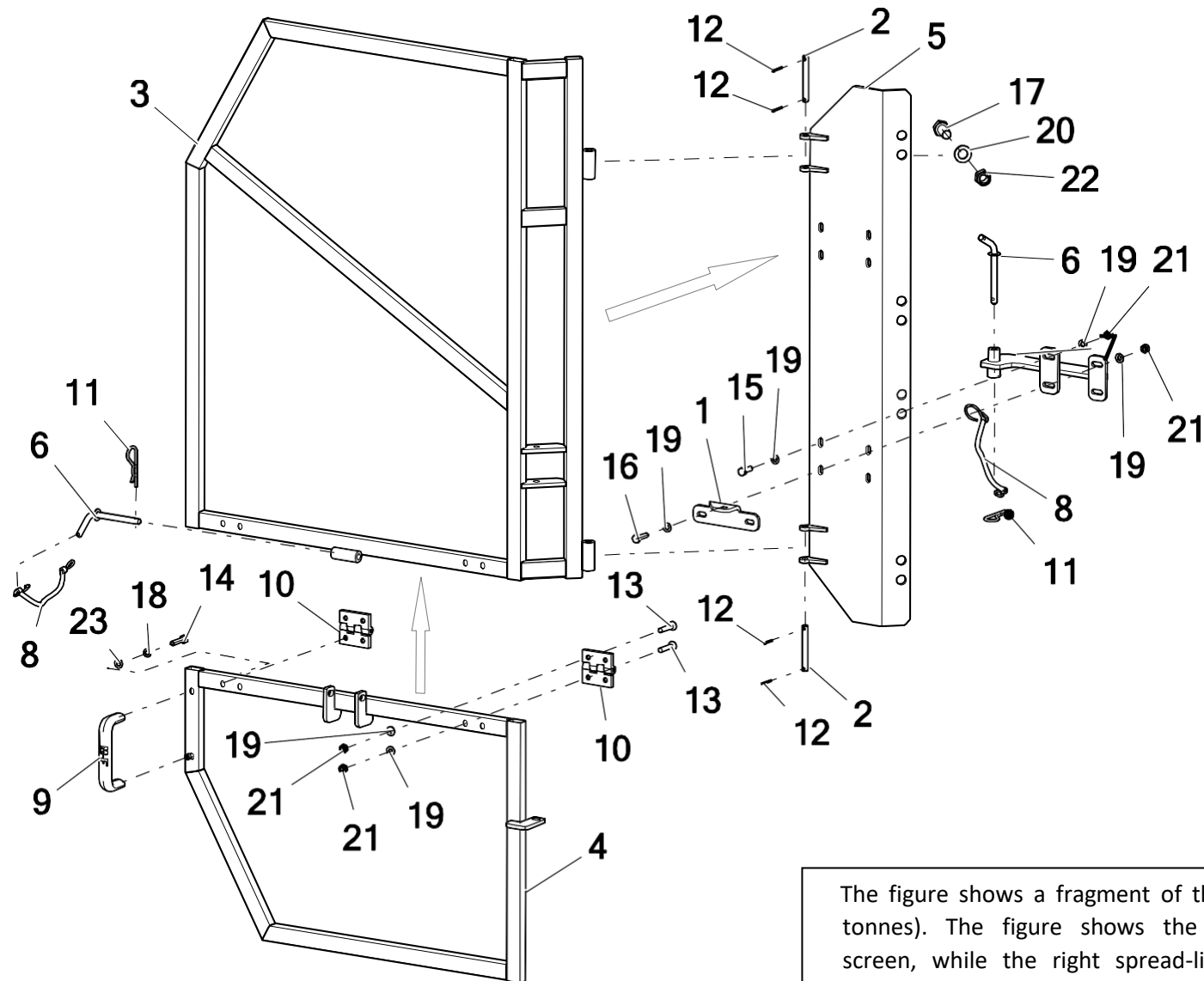

The figure shows a fragment of the N267 spreader (8 tonnes). The figure shows the left spread-limiting screen, while the right spread-limiting screen is its mirror image.



No.	Part or assembly name	Fig. or index No.					
		N267	Volume	N267/1	Volume	N267/2	Volume
1	Lock II	N267 23.00.01	1	N267-1 23.00.01	1	N267 23.00.01	1
2	Hinge pin	N267 23.00.02	2	N267 23.00.02	2	N267 23.00.02	2
3	Upper right screen wing	N267 23.10.00P	1	N267-1 23.10.00P	1	N267 23.10.00P	1
4	Bottom left screen wing	N267 23.11.00L	1	N267 23.11.00L	1	N267 23.11.00L	1
5	Mounting, complete	N267 23.20.00.1	1	N267-1 23.20.00	1	N267 23.20.00.1	1
6	Lock pin	N267 23.30.0	2	N267 23.30.0	2	N267 23.30.0	2
7	Locking support	N267 23.40.00	1	N267 23.40.00	1	N267 23.40.00	1
8	Rubber chain with a hook		2		2		2
9	Panel holder 465934	POD-TSZ-000195	1	POD-TSZ-000195	1	POD-TSZ-000195	1
10	Hinge N272 3.511.12 60 x 60, metal	POD-OGL-001043	2	POD-OGL-001043	2	POD-OGL-001043	2
11	Single spring cotter pin 4 (R-letter shaped, single )	23ZRFI4	2	23ZRFI4	2	23ZRFI4	2
12	Cotter pin 3.2 x 25 galv.	23Z32/25OC	4	23Z32/25OC	4	23Z32/25OC	4
13	Screw M8 x 40 galv.		2		2		2
14	Bolt 8x35 galv. 8.8 82105 82105	23S8/35OC 8.8	1	23S8/35OC 8.8	1	23S8/35OC 8.8	1
15	Bolt 8 x 25 galv. 8.8 82105 82105	23S8/25OC 8.8	1	23S8/25OC 8.8	1	23S8/25OC 8.8	1
16	Bolt 8 x 30 galv. 8.8 82105 82105	23S8/30OC 8.8	1	23S8/30 galv. 8.8	1	23S8/30 galv. 8.8	1
17	Bolt 16 x 40 galv. 8.8 82105 82105	23S16/40 8.8OC	1	23S16/40 8.8OC	1	23S16/40 8.8OC	1
18	Spring washer 8.2 galv. 82008	23P8SPOC	1	23P8SPOC	1	23P8SPOC	1

### 61. DEFLECTOR (SPREAD-LIMITING SCREEN)

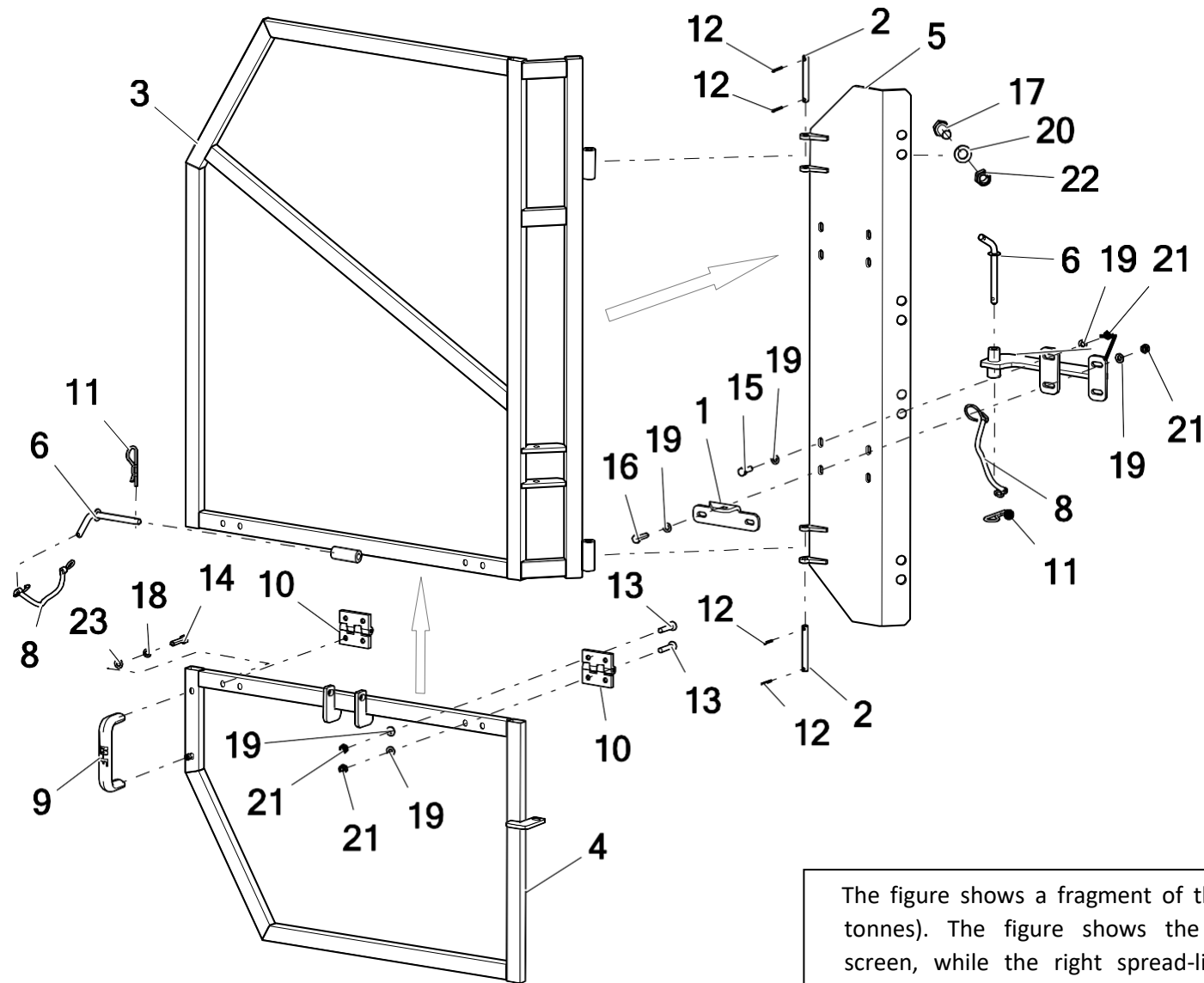

The figure shows a fragment of the N267 spreader (8 tonnes). The figure shows the left spread-limiting screen, while the right spread-limiting screen is its mirror image.

No.	Part or assembly name	Fig. or index No.					
		N267	Volume	N267/1	Volume	N267/2	Volume
19	Round washer 8 galv. 82005 82005	23P8OOC	6	23P8OOC	6	23P8OOC	6
20	Round washer 16 galv. 82005 82005	23P16OOC	1	23P16OOC	1	23P16OOC	1
21	Self-locking nut M8 galv. 82175 8 82175 8	23NS8OC	4	23NS8OC	4	23NS8OC	4
22	Self-locking nut M16 galv. 82175 8 82175 8	23NS16OC	1	23NS16OC	1	23NS16OC	1
23	Round washer 8 galv. 82005 82005	23POOC	1	23POOC	1	23POOC	1

## 62. NOTES

A series of 20 horizontal dotted lines provided for writing notes.



Metal-Fach Sp. z o.o. is constantly improving its products and adjusting its package to the needs of its customers, so it reserves the right to make changes to its product range without notice. Therefore, before making your purchase decision, please contact an authorised dealer or sales representative of Metal-Fach Sp. z o.o. Metal-Fach Sp. z o.o. will not accept any complaints regarding the data and pictures contained in the catalogue, as the presented range of products does not constitute an offer within the meaning of the provisions of the Civil Code.

The pictures do not necessarily show standard accessories.

Original spare parts are available from authorised dealers, both in Poland and abroad, and also at the Metal-Fach retail outlet.

#### TECHNICAL SERVICE

16-100 Sokółka, ul. Kresowa 62  
phone: +48 85 711 07 80; fax: +48 85 711 07 93  
serwis@metalfach.com.pl

#### SALES

16-100 Sokółka, ul. Kresowa 62  
phone: +48 85 711 07 78; fax: +48 85 711 07 89  
handel@metalfach.com.pl

#### SPARE PARTS WHOLESAL STORE

16-100 Sokółka, ul. Kresowa 62

#### Wholesale:

phone: +48 85 711 07 80; fax: +48 85 711 07 93  
serwis@metalfach.com.pl

#### Retail

phone: +48 85 711 07 80; fax: +48 85 711 07 93  
serwis@metalfach.com.pl

