



METAL-FACH



**REPAIR AND MAINTENANCE BOOK
BALE WRAPPER
Z237
MAY 2020**

Table of Contents

1	Identification, Bale Wrapper	4
2	Bale Wrapper cleaning	6
3	Storage	6
4	Dismantling and Disposal	7
5	Coupling to a tractor	8
5.1	Connecting with the drive	9
5.2	Drive disconnection.....	11
5.3	Drawbar components.....	12
6	Maintenance and adjusting.....	13
6.1	Machine maintenance.....	14
6.2	Scheduled inspections	15
6.3	The arrangement of the ongoing adjustment controls	15
6.4	Control levers.....	16
6.5	Film feeder	17
6.6	Support foot	18
6.7	Adjusting the hitch height.....	19
6.8	Adjusting the height of the revolution-counter sensor	20
6.9	Adjusting the tension of the chains	20
6.9.1	Adjusting the drive-chain tension for the service table	21
6.9.2	Adjusting the drive chain for the rollers of the service table	21
6.9.3	Adjusting the film-feeder chain drive.....	22
6.10	Adapting the wrapping for 500-mm film	23
6.10.1	Adapting the service-table chain drive for 500 mm film.....	23
6.10.2	Adapting the feeder for 500-mm film	24
6.11	Adjustment valves.....	24
6.11.1	The adjustment valve for the turntable lock.....	25
6.12	Adjusting the mechanical film-cutting device	26
6.13	Lighting transporting and servicing positions.....	28
7	Hydraulic system	29
8	Lighting system.....	31
9	Lubrication	32
9.1	Lubrication points.....	32
9.2	Lubrication interval.....	34
10	Metric-bolt-tightening torques	35
11	Possible faults.....	36
	NOTES.....	39



The information included in this Repair and Maintenance Book is valid as of the date of its drawing up. The manufacturer reserves its right to make design changes to machines, and due to this, some values or illustrations might not correspond to the actual state of the machine supplied to the user. The manufacturer reserves its right to make design changes without amending this Repair and Maintenance Book.



CAUTION

CAUTION

When repairing and maintaining the machine, use the Repair and Maintenance Book and the Instruction Manual written for this machine model.

1 Identification, Bale Wrapper

Identify the Bale Wrapper on the basis of the rating plate permanently fixed to the Bale Wrapper's main frame.

<p>A METAL-FACH SP. Z O.O.</p> <p>B S1a</p> <p>C e9*167/2013*11029</p> <p>D SUMZ310M0JSSK0001</p> <p>E 750 kg</p> <p>F A-0: 200 kg</p> <p>G A-1: 750 kg</p>	<p>METAL-FACH® ul. Kresowa 62, 16-100 Sokółka, Poland tel.: +48 (85) 711 98 40-45, fax: +48 (85) 711 90 65</p> <p>Owijarka bel</p> <p>Typ handlowy <input type="text" value="Z237"/> Nacisk na zaczep <input type="text" value="1,96"/> kN</p> <p>Wariant <input type="text" value="1A2RNRLMR"/> KJ <input type="text"/></p> <p>Rok produkcji <input type="text" value="2018"/></p> <p>VIN <input type="text" value="SUMZ310M0JSSK0001"/></p> <p>CE</p> <p>www.metalfach.com.pl</p>
--	--

Figure 1. Rating plate

Key to the fields on the rating plate:

- A** – Manufacturer's name;
- B** – Category, Subcategory, and Vehicle-Speed Indicator;
- C** – EU-Type Approval Number;
- D** – VIN;
- E** – Permissible total design weight of the vehicle;
- F** – Vertical load at coupling point;
- G** – Permissible design weight per front axle.

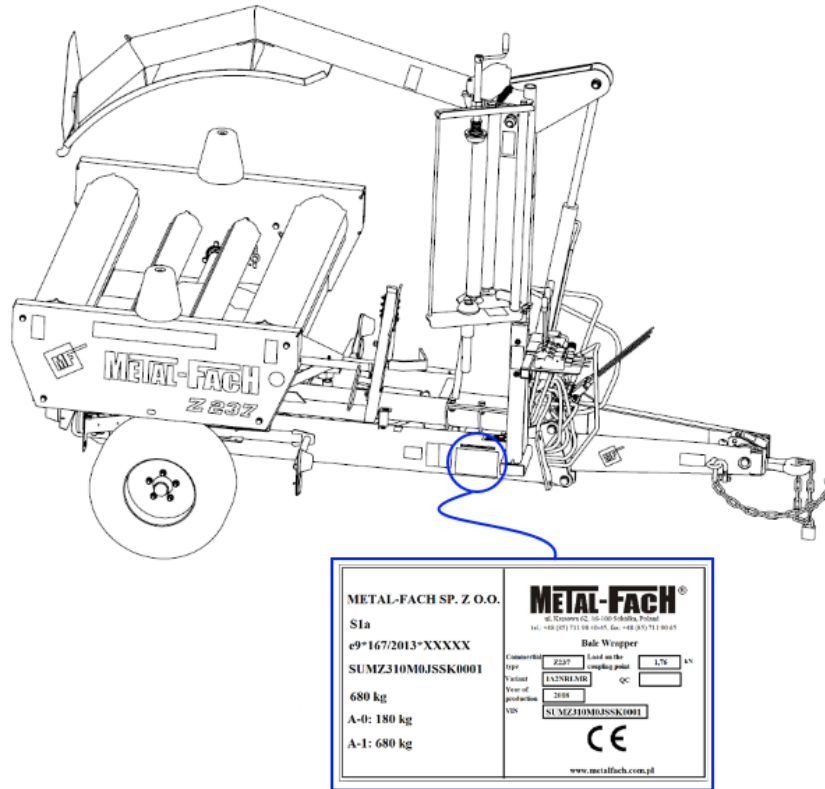

Figure 2. The location of the rating plate

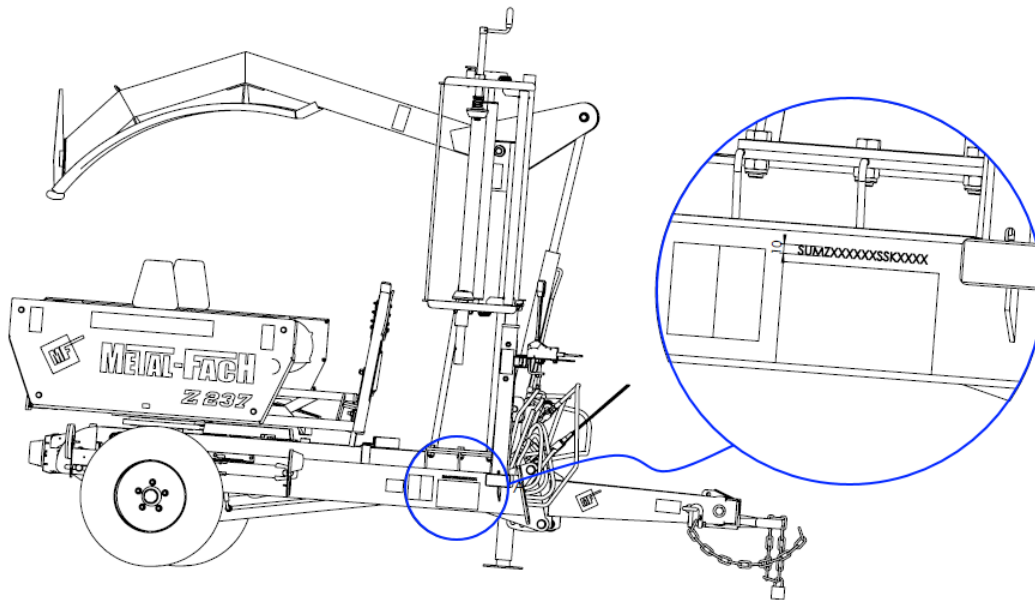

Figure 3. VIN number on the machine

2 Bale Wrapper cleaning



Use great care with the use of pressure devices during the cleaning procedure. The bearings and the bolt, hydraulic, and electrical connections are not water-resistant. Do not expose these components to water for a long time. Every time you clean the machine with water, these components must be lubricated again. Dry the places where the electrical bundle sheath is damaged, and protect them with water-resistant repair tape for electrical bundles.

Cleaning the machine after use,

- Clean the machine of all vegetation, its residues, and other dirt.
- Clean the lighting components.
- Clean the warning pictograms and the rating plate to keep them legible.
- Wipe the film-tensioner rollers to remove dirt; denatured alcohol can be used for this.
- The service-table rollers can be washed with water with detergent and a pressure device.

Protecting the machine after cleaning

- After you have cleaned the machine with water, lubricate bearings, gaskets, and articulated connections again.
- Apply a layer of a plant-origin oil on the film cutter's blades.
- Protect any coating defects and protective-layer scratches with anti-corrosion agents and paint.
- Damaged safety stickers must be renovated or added as required.

Clean the soiled L-02 counter casing with a damp piece of cloth with some detergent. Do not use organic solvents for washing (e.g. acetone, benzine, nitro solvent), as it can result in damage to the panel casing.

3 Storage

Post-season or if the Bale Wrapper is not to be used for a long time perform the following tasks.

- Remove the film rolls from the feeder
- Clean the machine (**Section 2**)
- Carry out the recommended maintenance work (**Section 6**)
- Repair or replace parts if damaged
- Set the machine on a level, compacted, surface to prevent the Bale Wrapper from rolling
- It is recommended to store the Bale Wrapper under roofing or a protective waterproof tarpaulin
- Storing the Bale Wrapper in its transporting position with the loading arm secured against dropping is recommended
- Store the Bale Wrapper in a manner that does not compromise the safety of persons or animals. The film cutter fitted with sharp blades must remain in the closed position
- Ensure the good condition and legibility of the rating plate. If damaged, contact the service centre

- Store the wrap counter in a dry room protecting the terminals against dirt and humidity
- Lock out the machine against unauthorised use (**use of a padlock chain, a standard component on a bale wrapper drawbar**).
- Check the condition and legibility of the pictograms. In the case they are damaged replace them with new ones.



CAUTION

CAUTION!

Store the Bale Wrapper in an atmosphere free from aggressive factors (e.g. ammonia, chemicals).

4 Dismantling and Disposal

Dismantling and disposal should be performed by specialized services familiar with the construction and operation of the Wrapper. Only specialised service centres have the full and up-to-date knowledge on the applied materials and risk associated with the hazards of improper storage and transporting. The authorized services provide both counselling and performance of the complete services concerning the disposal of the machine.

The correct tools and auxiliary equipment (hoist, lifting jack, wheel puller) must be used for dismantling.



CAUTION

CAUTION!

Store the used oil in air-tight containers. Take it to a petrol station that collects used oil immediately.



CAUTION

CAUTION!

Dismantle the machine. Sort the dismantled parts. Deliver the dismantled parts to the relevant recycling points.



During the dismantling of the Wrapper wear the proper protective clothes and protective boots.

5 Coupling to a tractor

Prior to the commencement of connecting the Bale Wrapper to the tractor make sure that it fulfils all the requirements. Combine the Bale Wrapper Z237 with a farm tractor with power of at least 30 kW and a pull class of at least 0.9.

The tractor must be provided with at least two power-hydraulics quick-release sockets (acc. to ISO 7241-1, type A, size 12.5), affording pressure supply and the free return of oil from the Wrapper's distributor to the tractor's oil tank. The tractor's hydraulic installation must allow the switching off of the hydraulic supply of the working sections from the tractor's operator's seat in the tractor's cockpit.

The tractor must be fitted with a 12 V power socket with a 10 A fuse (lighter socket). Recommended capacity of the tractor's pump is 25 l/min

Connect the Bale Wrapper to the lower tractor's hitch, which facilitates the transmission of a vertical load of 2.5 kN.

Prior to connecting the wrapper with the tractor the operator must make sure that the wrapper is complete and all the bolts are tightened correctly (see **Section 10** for the table of bolt-tightening torques).

Make sure that the points marked for lubrication are actually greased. If it is not the case, have them lubricated. (**Section 9.**)



DANGER

DANGER!

The machine's working area is considered a danger zone. Prior to starting up the machine, make sure that there are neither people nor animals in the near proximity of the machine. Stop the Bale Wrapper immediately if any persons come near the machine and require any unauthorised persons to leave this zone. Never stop in the close proximity of or under terraces or balconies, in front of open rooms, or any kinds of platform, where persons or animals can stay. The Bale Wrapper's operator is responsible for all damage caused by the machine during operation.



CAUTION

CAUTION!

Make sure that in the area of connecting the wrapper with the tractor and in the near vicinity, there are no third parties present, especially children.



WARNING

WARNING!

Wear well-fitting clothes that cannot be caught by movable elements, and boots with non-slip soles. In case of the hazard of an item being ejected wear a protective helmet with eye protection.



CAUTION

CAUTION!

Make sure the power hydraulic system is tight. In order to check that there are no leaks from the hoses use tissue paper or other paper.



CAUTION

CAUTION!

Standing near the machine while operating the Bale Wrapper poses the threat of impact or crushing. Exercise special caution while coupling and uncoupling the machine's hitch.

5.1 Connecting with the drive

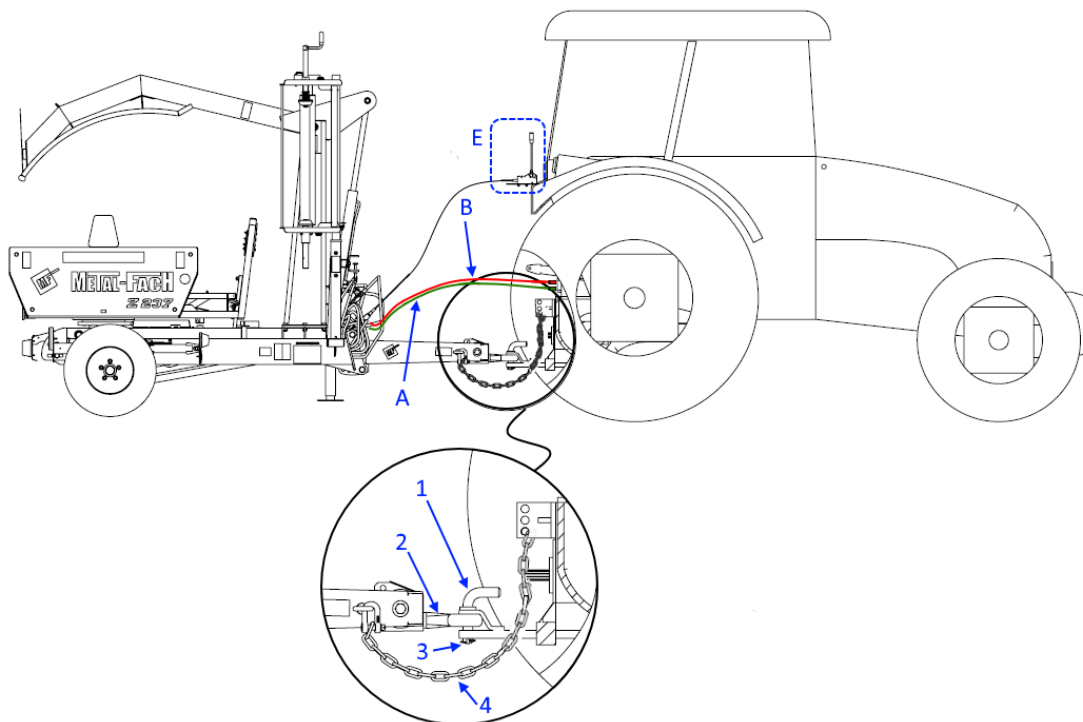

Figure 4. Connecting the hitch and drive of the Bale Wrapper

- Connect the Bale Wrapper to the lower or upper tractor's hitch, whichever allows the transmission of a vertical load of 4.2 kN. Check stability and manoeuvrability with the tractor.
- Make sure that in the area of the Bale Wrapper coupling with the tractor and in the near vicinity there are no bystanders present, especially children.
- While connecting with the tractor, position the machine along the tractor's axis on paved, even and level ground. Stop the tractor's engine, take the key from the ignition, and engage the tractor's parking brake.
- Level the Bale Wrapper by means of the adjustable support foot, and by setting a suitable hitch height at an appropriate adjustment eye.
- Remove the padlocked chain, which protects the machine against unauthorised use, from the hitch eye.



CAUTION

CAUTION!

Couple the drawbar eye with the tractor's agricultural hitch only and check the connection for correctness, and the protection against accidental disconnection.

- Start the tractor and drive it towards the Bale Wrapper so that the opening in the hitch eye of the tractor aligns with the opening in the hitch eye of the Bale Wrapper. The opening diameter in the hitch eye is 45 mm.
- Stop the tractor's engine, take the key from the ignition, and engage the parking brake.
- Attach the Bale Wrapper hitch eye (2) by means of a suitable hitch pin (1), and secure the pin against spontaneous detachment (3).
- Use a chain (4) to provide additional security against detachment of the combination by fastening it between the Bale Wrapper hitch and the tractor. It will ensure residual controllability of the Bale Wrapper if the machines are suddenly uncoupled.
- Put the panel with the control levers (E) in the tractor's cab.
- Connect the hydraulic supply system by plugging the supply hose plug (A) and the return hose (B) in the supply sockets of the hydraulic tractor.
- Adjust the support foot and set it to the transporting position.
- Before you start working or enter public roads, ensure the ground-wheel bolts are tightened correctly.
- Before you enter public roads, connect the Bale Wrapper's lighting system (**Section 8**) to the socket in the tractor. Check the road lighting for correctness. Check the axle shaft for locking in position.
- Start the tractor, switch on the control panel and check the correct operation of the power hydraulic systems, without the bale and without film in the feeder.



CAUTION

CAUTION!

While connecting with the tractor, position the machine along the tractor's axis, on paved, even, and level ground. Stop the tractor's engine, take the key from the ignition, and engage the tractor's parking brake. Set the proper level of the hitch by selecting the appropriate adjustment eye to level the Bale Wrapper.

5.2 Drive disconnection

The procedure for uncoupling the Bale Wrapper from the tractor

- Make sure that in the area of the Bale Wrapper coupling with the tractor and in the near vicinity there are no bystanders present, especially children.
- If it is possible, set the Bale Wrapper's components in the transporting position.
- If the Bale Wrapper is to be idle for a long time, lower the loading arm, or fit a lock to the same.
- Position the Bale Wrapper in its storage place on even and level ground.
- Stop the tractor's engine, take the key from the ignition, and engage the tractor's parking brake.
- Disconnect both the power supply and lighting systems, wind the wires up, and put them away under the spare film-roll containers.
- Disconnect the power hydraulics system and protect the hydraulic hoses in their clamps on the Bale Wrapper's frame (**Fig. 5 - 1**).
- Put the panel with the control levers of the Bale Wrapper in the holder on the pole of the machine's film feeder.
- Lower the support foot from its transporting position to the working position.
- Make sure that there is no risk of accidental machine displacement.
- Disconnect the drawbar eye from the transport hitch of the tractor. Detach the additional chain that links the hitch with the tractor (**Fig. 4 - 4**).
- Fit the drawbar eye with the protection against unauthorised use (**Fig. 6 - 1**).

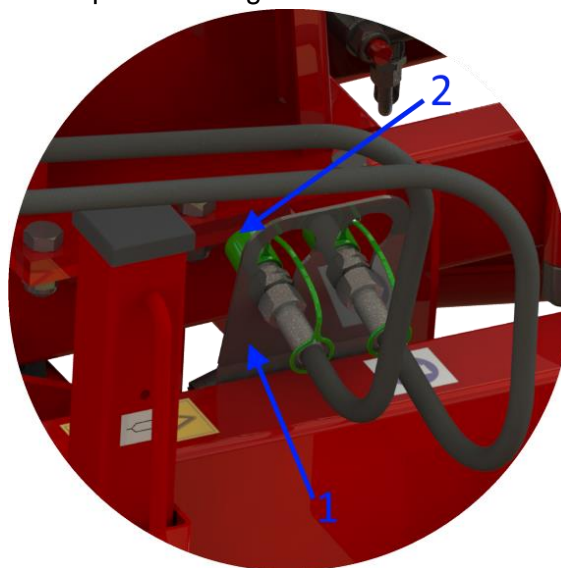

Figure 5. Place for storing hydraulic hoses
1 – hose bracket, 2 – plastic cap



CAUTION

CAUTION!

Hydraulic connections must always be kept clean. After use reinstall plastic cover supplied with the machine purchase.



CAUTION

CAUTION!

After disconnecting the Wrapper from the tractor, its control panel should be stored in a dry, safe, place, away from the reach of unauthorised persons, especially children.



CAUTION

CAUTION!

After disconnecting the Bale Wrapper from the tractor wind up and store its power-supply wires and the communication cables of the control panel in the dedicated box.

5.3 Drawbar components

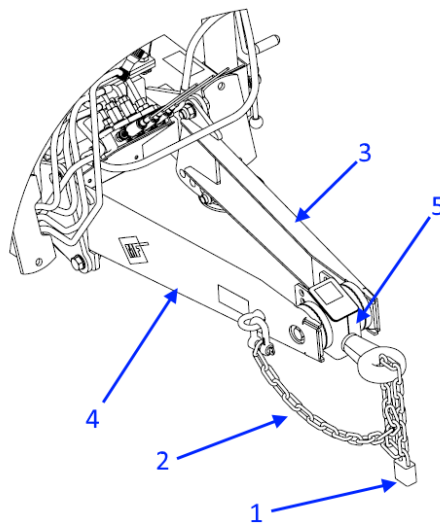

Figure 6. Drawbar components

Key for the Z237 Bale Wrapper's drawbar components (**Fig. 6**)

1. Chain with a padlock and key set (protection against unauthorised use of the machine)
2. Chain with a connecting shackle (additional protection against combination detachment)
3. Left drawbar arm
4. Right drawbar arm
5. Hitch with swivel eye

6 Maintenance and adjusting

While performing the operation-maintenance works you should wear the appropriate protective clothes and boots, adequate for the activities to be performed and substances with which you will be in contact.

Do not repair leakages from the pressurised devices and hydraulic elements.

In the case of damage to machine parts they should be replaced with new, original parts. The application of non-original or incorrect parts results in the loss of the machine guarantee.

Unintended operation of the Bale Wrapper or operation by unauthorised persons who do not have the right qualifications must be strictly avoided.

The accidental starting up of the machine must be prevented.

If it is necessary to carry out works on Bale-Wrapper elements that cannot be reached standing on the ground, only equipment intended for ascending (safe ladders) can be used. Do not use the Bale Wrapper's components for climbing the machine.



Tighten the bolts on fixed connections according to the values of tightening torques shown in **Section 10**.

Tighten the bolts on moving connections so that the lowest-possible play is achieved and their mobility is preserved.

Follow the check lists while connecting the machine with the tractor, starting it, and disconnecting the Bale Wrapper from the tractor.



It is recommended to run an operation and maintenance activities log book. It will facilitate continuous insight into the machine's technical condition and avoid the need for repair activities in the field.

Hydraulic-oil leakages to the environment must be prevented.

Carry out repairs to the hydraulic installation in a place where there is no danger of oil penetration into the soil, ground water, food, or animal fodder. Use tight and safe containers to store used oil.

If it is necessary to conduct operation-maintenance activities under elevated machine parts (e.g. wheel replacement), they must be protected against lowering by installing stable supports underneath.

When changing a wheel, lift the Bale Wrapper using the points marked with the jack

pictogram .



CAUTION

CAUTION!

Do not inflate the tyres over the recommended pressure. For unladen machine this is 3.5 bar.



CAUTION

CAUTION!

Use original spare parts only.

Original spare parts by Metal Fach are made to match the specific needs of the devices produced by Metal Fach.

Parts from other manufacturers are not inspected or approved by Metal Fach. To avoid risk, use the original spare parts by Metal Fach only.

6.1 Machine maintenance



To maintain the proper working order and service life of the moving components of the machine, follow the guidelines laid down in the maintenance table (Table. 2) and carry out regular inspections of the machine. The maintenance work is to be carried out on the Wrapper set in the working position. If any other position needs to be used, it will be noted accordingly.



Use the greases class EP 2 or EP 3 (e.g. LT-43 EP-3) as plastic grease. Use a grease gun to apply lubrication via the grease nipples. Use a brush covered with grease to lubricate sliding surfaces. As for the roller chains, it is recommended to use greases and oils dedicated for roller chains.

It is recommended to remove as much of the previous residual grease as possible from the sliding surfaces before carrying out the lubrication, as it can contain contaminations (sand, organic impurities) that can cause quicker part degradation or loss of grease properties. After carrying out the lubrication, remove the excess grease spilt from the lubrication points so that you prevent them from attracting dirt and hampering the machine's operation.

6.2 Scheduled inspections

Periodic routine inspections are recommended to be performed after each two seasons of machine use. For replacements it is recommended to use original spare parts that will assure the maintenance of the wrapper in full efficiency for a long period.

Replace the power hydraulics rubber hoses every 5 years.

Follow the procedure below to change the oil in the angle gearbox of the machine every two years.

- Position the machine on level ground
- Place a suitable, tight, container under the drain plug
- Unscrew the inlet, drain and overflow plugs
- Once the oil has been drained, replace and tighten the drain plug
- Pour 80W90 transmission oil through the inlet hole up to the overflow-cap level
- Tighten the overflow and inlet plugs
- Take the used oil to a petrol station that deals with this product.

6.3 The arrangement of the ongoing adjustment controls

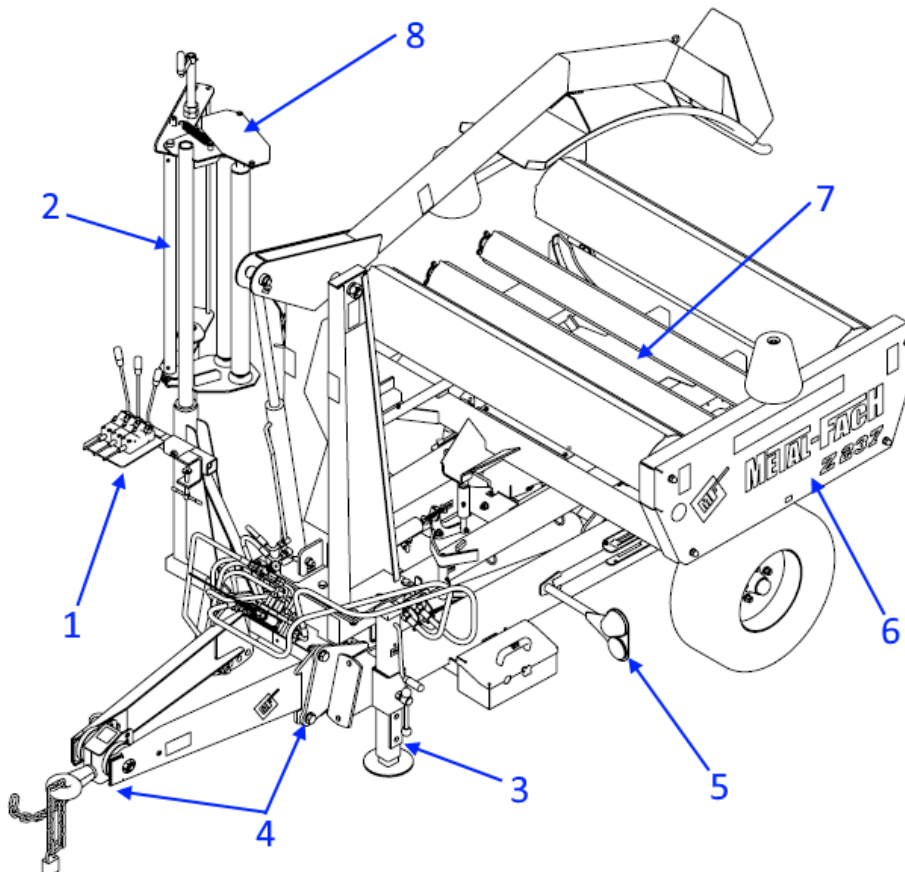

Figure 7. Components to be adjusted on an ongoing basis

- 1 – control lever, 2 – film feeder, 3 – support foot, 4 – hitch height adjustment, 5 – lighting, 6 – roller chain drive, 7 – intersecting axis gear, 8 – film feeder chain drive, 9 – film cutter, 10 – service table chain drive, 11 – film roll adjustment device, 12 – revolution counting sensor

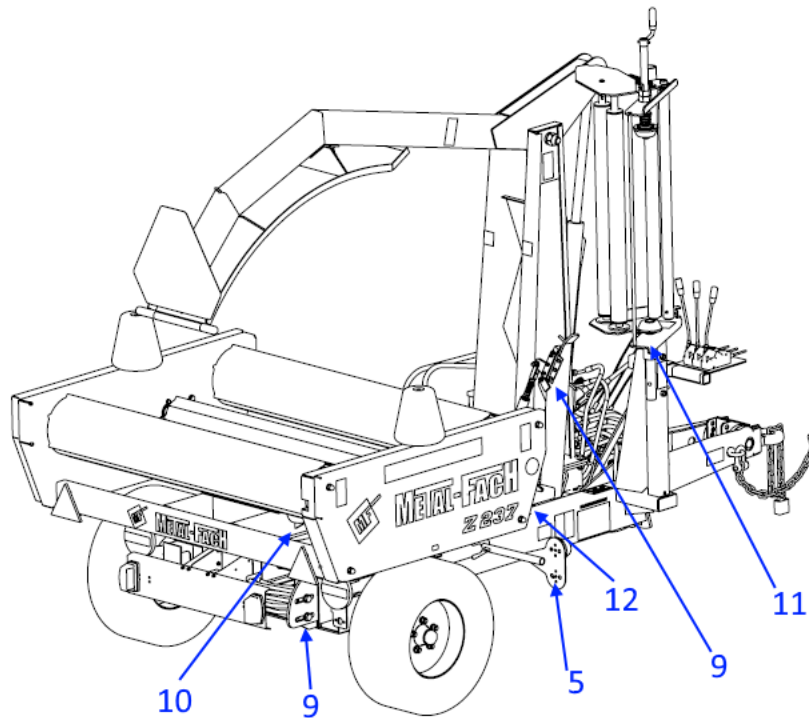



Figure 8. The continuous adjustment components
 1 – control lever, 2 – film feeder, 3 – support foot, 4 – hitch height adjustment, 5 – lighting, 6 – roller chain drive, 7 – intersecting axis gear, 8 – film feeder chain drive, 9 – film cutter, 10 – service table chain drive, 11 – film roll adjustment device, 12 – revolution counting sensor

6.4 Control levers



CAUTION!
 Before starting the Bale Wrapper, install the control levers in the tractor's cab.

CAUTION

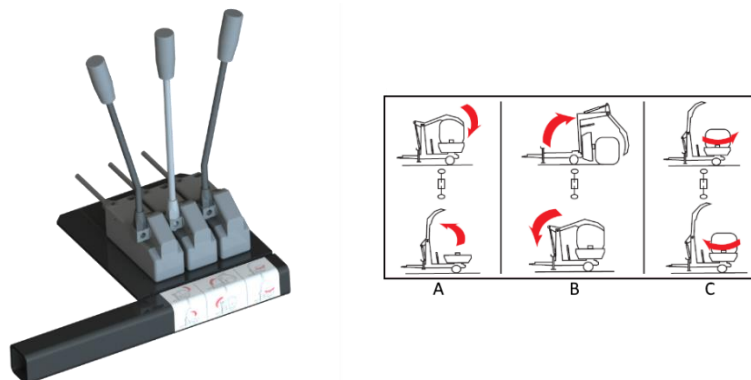

Figure 9. The pictograms on the control lever panel.
 A – raising and lowering the loading arm
 B – raising and lowering the turntable, C – table revolution



CAUTION

CAUTION!

When controlling the Bale Wrapper, follow the principles below to move the levers: try to start and finish the movements of the machine's working parts smoothly. Sudden and reckless movements can result in machine damage.

The control-lever panel is fitted with a clamp for securing it in the tractor's cab. Fix the lever panel firmly so that it does not hamper driving the tractor or make the use of the control levers difficult during operation.

6.5 Film feeder

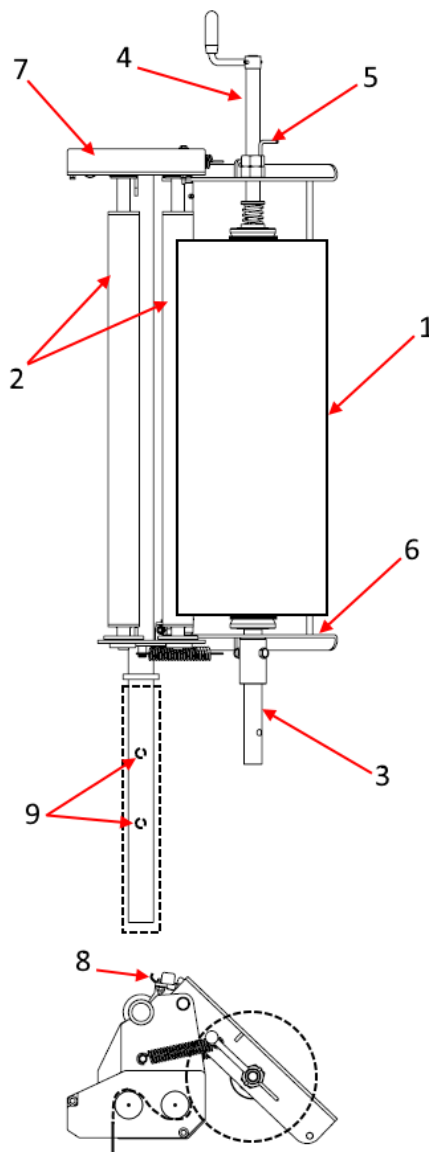

Figure 10. Film feeder 1 – film roll, 2 – pre-stretchers, 3 – upper roll holder, 4 – lower roll holder, 5 – jam nut, 6 – film flow sticker, 7 – pre-stretcher gear, 8 – hook securing a bracket, 9 – setting screws for feeder angle

The film feeder is a device that feeds a band of film to be wrapped around a bale that is being rotated on the turntable. A 500- or 750-mm film roll is placed in a rotary position, contained in a feeder frame, between the upper and lower roll holder centrelines. The band of film is unwound between the pre-stretchers, which stretch the film from the beginning of the wrapping process. The ratio on the chain drive between the roller near the roll and the outer roller is 1.75.

The film should be pre-stretched at 70-80%, but it might vary due to different types and properties of films.

6.6 Support foot

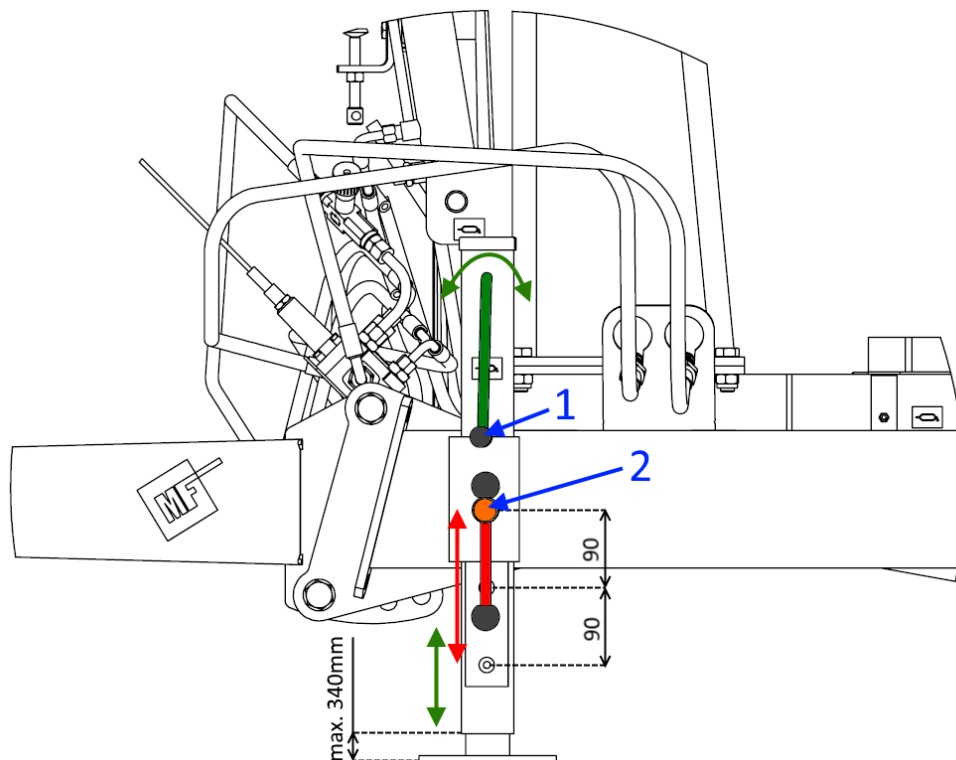

Figure 11. Support foot of the Bale Wrapper

The support foot features two adjustment levels (**Fig. 11**): 1 a non-step adjustment of the level of support within 340 mm changed with a hand wheel (crank), and 2 a three 90-mm step adjustment, set with a hand wheel.



CAUTION

CAUTION!

Use the step adjustment of the support foot only when the Bale Wrapper is connected to the tractor's hitch.

Loosening the setting hand wheel when the drawbar is not supported can result in crushing.

When the machine is not coupled with the tractor, the support foot is used to prop the machine firmly. Use it to level the Bale Wrapper when coupling the machine with the tractor.

6.7 Adjusting the hitch height

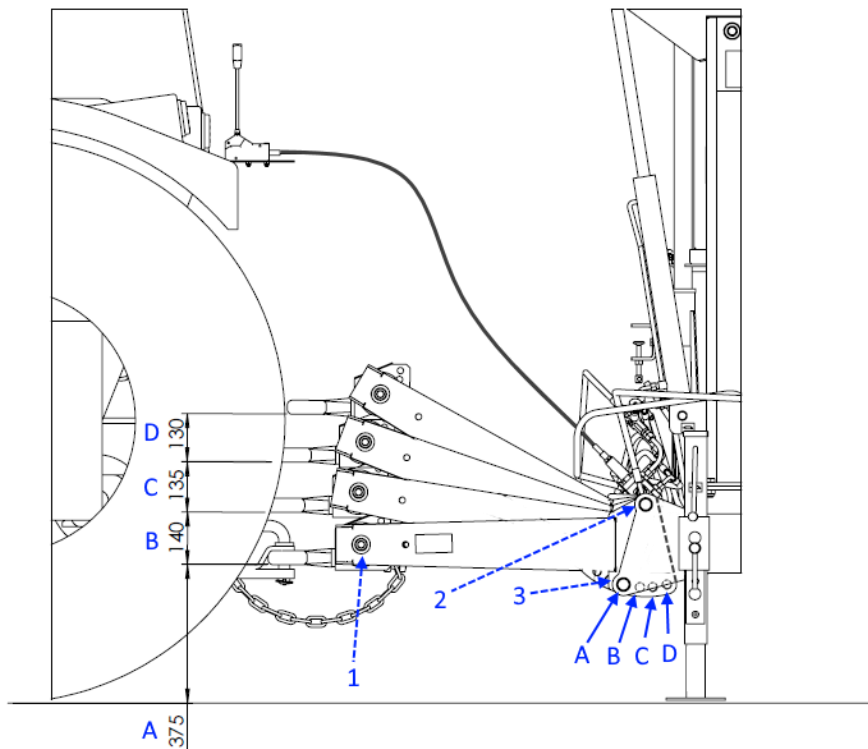

Figure 12. Adjusting the hitch height

The Bale Wrapper's hitch is supplied with four height settings, 375, 515, 650, and 780 mm above the ground.

Follow the adjustment procedure (**Fig. 12**).

- Position the tractor as closely as possible to the hitch eye of the Bale Wrapper.
- Level the Bale Wrapper with the ground using the support foot.
- Loosen the M20 nut **(1)** that locks the hitch eye in place.
- Loosen the M20 nuts **(2)** on the bolts that are rotary pins of the drawbar mounted on the main frame.
- Loosen the M20 nuts **(3)** on the bolts that set the height of the drawbar and remove the bolts.
- Set the drawbar to the required height by slotting the bolt into a proper hole – positions A, B, C or D.
- Set the hitch eye to the horizontal position by turning it on the curved link.
- Secure the hitch-eye connection by tightening the bolt and nut **(1)** to a torque of 400 Nm.
- Secure the connection of the drawbar and the Bale Wrapper frame by tightening the bolts and nuts **(2)** and **(3)** to a torque of 400 Nm.

6.8 Adjusting the height of the revolution-counter sensor

Follow the sensor-adjustment procedure.

- Loosen the bolts that lock the sensor and put its setting to the lowest level possible.
- Start the tractor, and position the service table so that the activating magnet is over the sensor.
- Switch off the tractor's engine, set the hydraulic manifold levers to neutral, and apply the parking brake.
- Turn the power supply on for the L-02 counter, turn the counter on, and set it to the rev-counter mode.
- Set the sensor at such a distance from the magnet as to enable pulse counting; usually it is 10-15 mm. Each pulse is signalled by a short sound from the counter.
- Fit the sensor in the correct position using the sensor's nuts.
- Put the counter panel in the tractor, start the tractor and turn the table to check whether the revolutions are being counted on the L-02 counter.

6.9 Adjusting the tension of the chains

Two chain drives are designed in the Bale Wrapper to drive the service table and rollers, and one chain drive for the correct ratio of the pre-stretchers in the foil feeder.



Routine checks of chain tension must be performed after wrapping 120 bales.

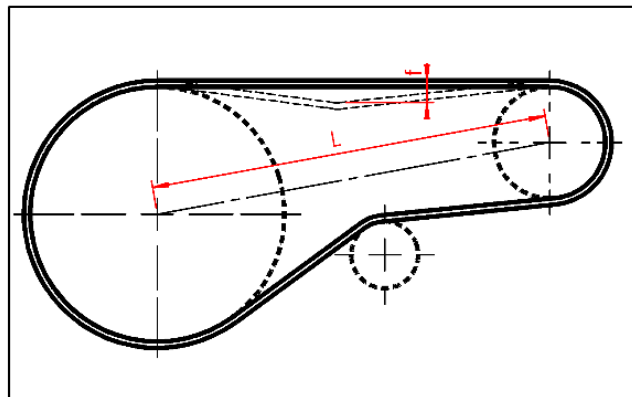

Figure 13. Chain-tension adjustment – determining a chain bend: f – chain bend value, L – distance between the sprocket centre lines

$$f = 0.01 \times L$$

6.9.1 Adjusting the drive-chain tension for the service table

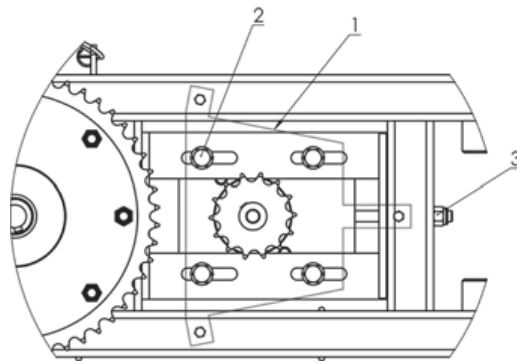

Figure 14. Drive-chain adjustment
1 – chain guard, 2 – M12 nuts, 3 – chain tensioner bolt

Two chain drives are used for the Bale Wrapper's turntable and rollers. Tension the drive chains after wrapping the first 10 bales (**Fig. 14**).

- Dismount the chain guard (1)
- Loosen the 4 M12 nuts (2)
- Tighten the M12 bolt for the chain tensioner (3) so that it results in a 20-mm bend of the chain
- Tighten the 4 M12 nuts (2)
- Install the chain guard

6.9.2 Adjusting the drive chain for the rollers of the service table

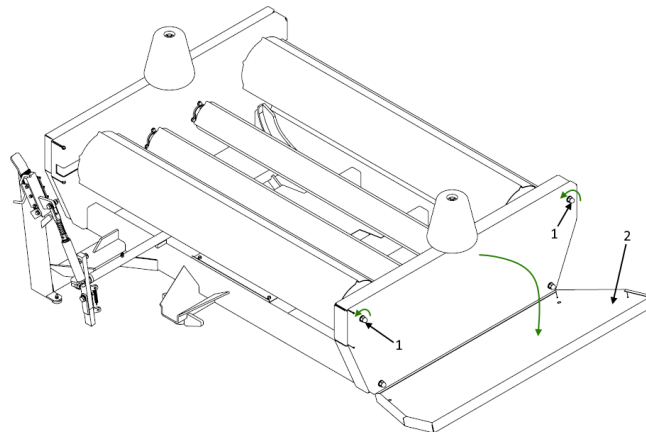

Figure 15. Dismount the guard of the roller-drive chain

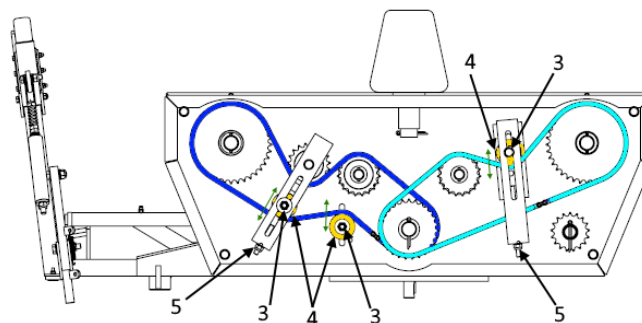

Figure 16. Adjust the tension of the roller-drive chains

Follow the procedure below to adjust the chain tension in the drive of the service-table rollers (**Fig. 15, 16**).

- Loosen the M12 nuts (**1**) that lock the guard (**2**), and open it.
- Loosen the M12 nuts (**3**) that lock the sliding bushes of the tensioners in place.
- Use the adjustment nuts (**5**) to set the correct tension of the drive chains.
- The correct tension is characteristic of a chain bend of 10–15 mm.
- Once the chain tension is set, tighten the locking nuts (**3**).
- Replace the guard (**2**) and secure it by tightening its nuts (**1**).



For the hydraulic film-cutter version, the roller-drive chain is on the opposite side of the service table and mirrors the Bale Wrapper drive chain in the mechanical film cutter.

6.9.3 Adjusting the film-feeder chain drive

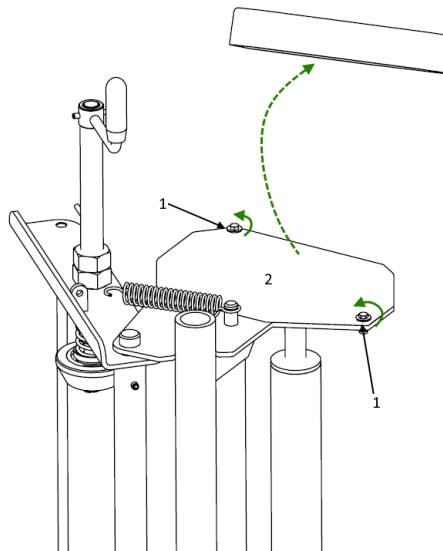

Figure 17. Dismount the guard of the feeder chain drive

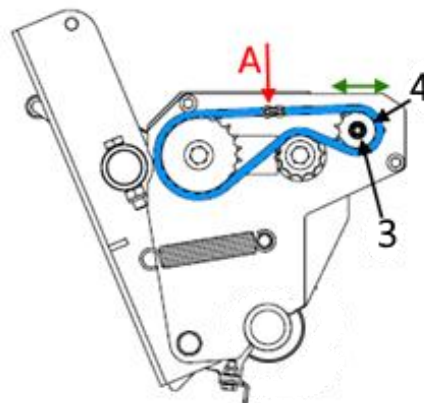

Figure 18. Adjust the tension of the feeder drive chain

Follow the procedure below to adjust the chain tension in the drive of the service-table rollers (**Fig. 17, 18**).

- Loosen the M8 bolts (1) that lock the drive guard (2) and open it.
- Loosen the M12 nut (3) that locks the tensioner (4)
- Shift the tensioner left so that the chain bend at point (A) is 5-10 mm
- Once the chain tension is set, tighten the locking nut (3).
- Replace the guard (2) and secure it by tightening its bolts (1).

A correctly tensioned drive chain will facilitate the smooth rotation of the film pre-stretchers. If the rotation of the rollers is obstructed or blocked, it can be caused by excessive tension of the drive chain.

6.10 Adapting the wrapping for 500-mm film

The Bale Wrapper is factory set to wrap with film of 750 mm width. For wrapping with 500-mm film, change the sprocket of the roller drive (**Fig. 19**) and adapt the film feeder for 500 mm film (**Section 6.10.2**).

6.10.1 Adapting the service-table chain drive for 500 mm film

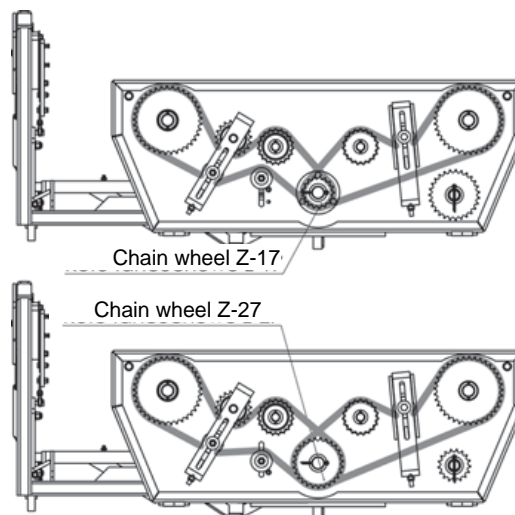

Figure 19. Sprockets of the roller-drive chains

- Loosen the 4 M12 cap nuts, remove the side guard of the rotary frame (on the drive chain side).
- Loosen the M12 bolts of the chain tensioners.
- Remove both chains from the Z-27 sprocket installed on the main shaft and remove the pin that locks this sprocket in place.
- Dismount the Z-27 sprocket from the shaft using a proper extractor.
- Dismount the Z-17 sprocket from the spare sprocket bar, replace it with the Z-27 sprocket, and secure it with the pin.
- Mount the Z-17 sprocket on the drive shaft.
- Secure the Z-17 with the pin, mount the chains, and adjust their tension.
- Fit the side cover.

6.10.2 Adapting the feeder for 500-mm film

- Loosen the M12 nut on the bolt that locks the upper roll holder spindle, and remove the locking bolt.
- Lower the upper spindle so that its adjustment hole is aligned with the locking hole in the locking bushes.
- Lock it in place again by fitting a locking bolt and lock it in place by tightening the M12 nut onto it.
- Tighten the lower roll holder shaft using the crank provided at a height that enables the mounting of the 500 mm film roll.

6.11 Adjustment valves

The hydraulic system of the Bale Wrapper is supplied with choke/non-return valves, used for setting the speed of the cylinder action. These valves have factory settings, but as the Bale Wrapper continues to be operated, readjustment might be necessary.

Before adjusting, switch off the tractor's engine, apply the parking brake, and take the key from the ignition.

Before adjusting the choke/non-return valve, turn it off and count the number of hand wheel turns while doing so. This will ensure the factory setting. It is advisable to take note of the values to return to the factory settings easily.

While adjusting, turn the valve hand wheel off and on by half a turn compared to the factory setting, depending on whether you want to slow down or accelerate the cylinder action.

Once the valve is set, check the functioning of a selected section, and, if the result is not satisfactory, turn the valve hand wheel on or off by another half a turn.

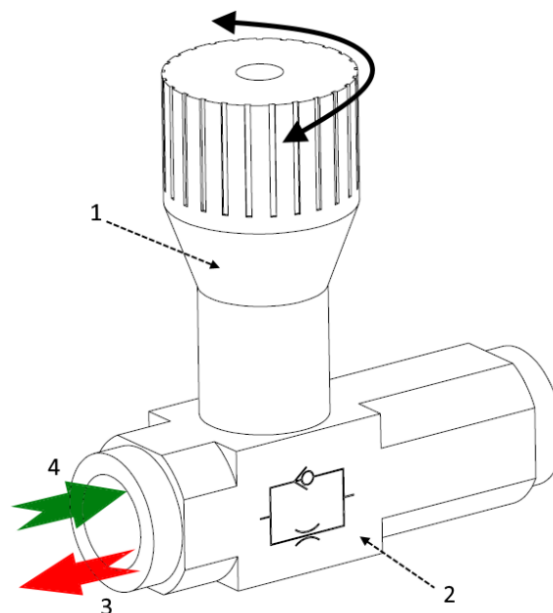

Figure 20. Choke/non-return valve, 1 – valve hand wheel, 2 – valve shell marked for the choking direction, 3 – choked flow direction, 4 – free flow direction



CAUTION

CAUTION!

Never adjust the valves while the tractor's engine and power hydraulic system are running.

The valve design allows the choking of the oil flow to be set in one direction, marked on the valve shell. Choking does not apply in the opposite direction.

6.11.1 The adjustment valve for the turntable lock

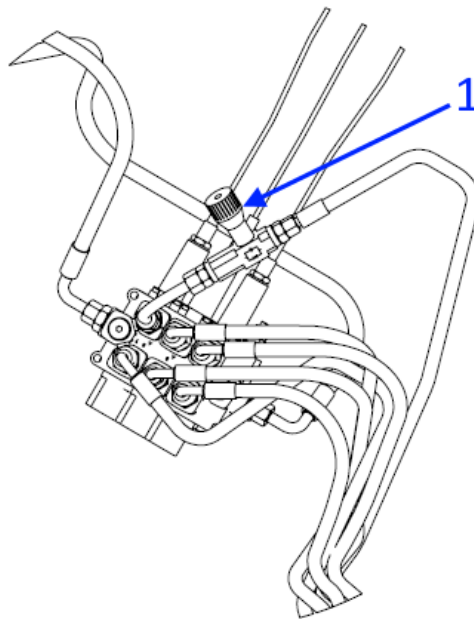

Figure 21. The location of the adjustment valve for the service table lock

The locking pin of the service table should move out during the reverse table revolutions, which is opposite to the wrapping direction.

If the locking pin fails to move out, turn the valve hand wheel (**Fig. 21 – 1**) by half a turn and check the locking action. Repeat if necessary.

If the locking pin moves out too quickly, or it falls after the control lever is released, turn the valve hand wheel by half a turn, and check the locking action. Repeat if necessary.



CAUTION

CAUTION!

When locking the service table, move the control levers smoothly and avoid sudden movements with the control lever. Locking the service table too abruptly can damage the locking unit.

6.12 Adjusting the mechanical film-cutting device

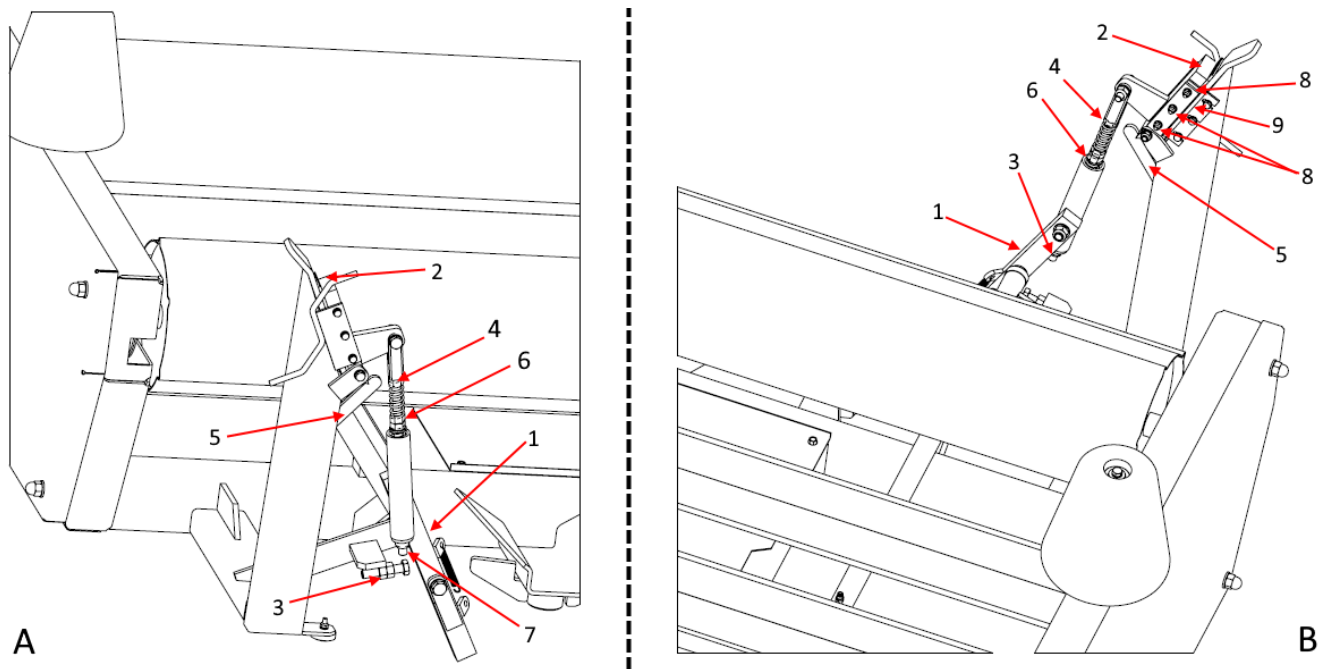

Figure 22. Enclosed film cutter A – front view, B – back view

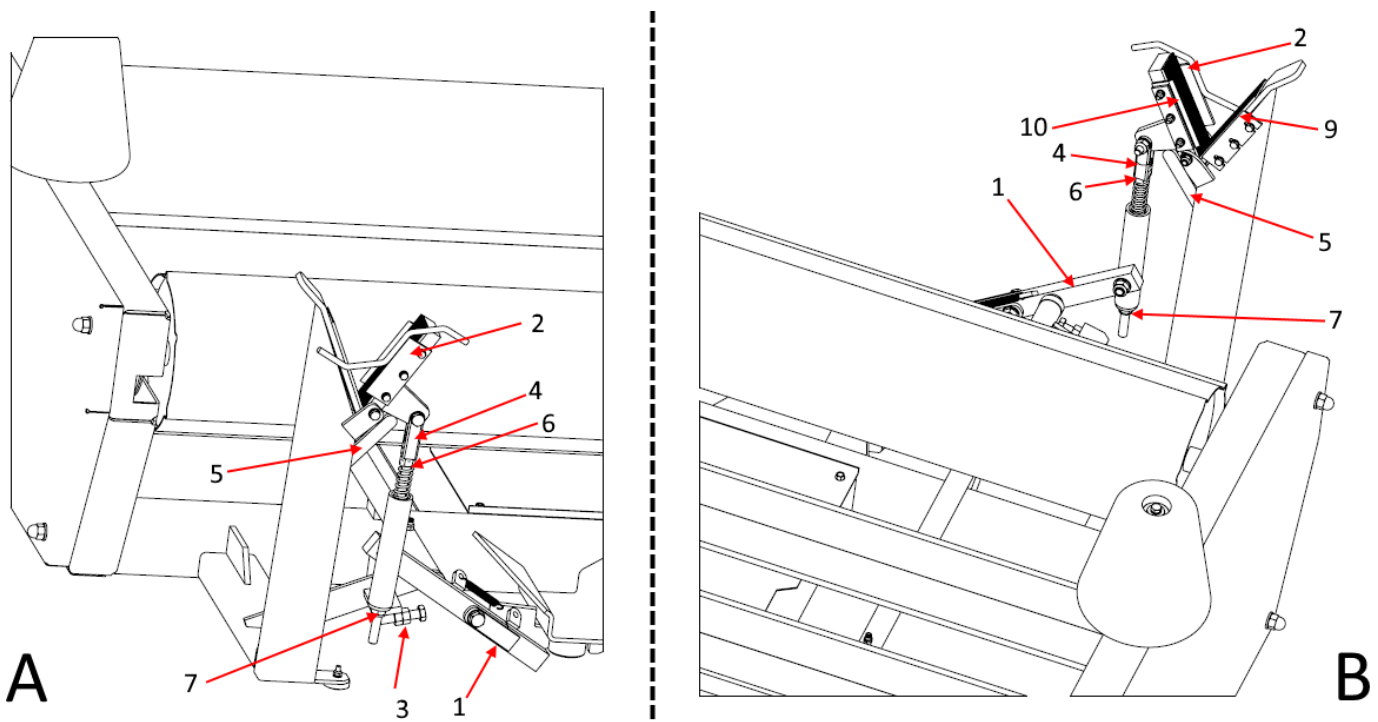

Figure 23. Open film cutter A back view, B front view

Adjusting the position of the film-cutter arm (**Fig. 22, 23**)

- The film-cutter arm (1) in its closed position must be set so that it retains the buffer position (2), and when the service table revolves, the lower part of the arm is able to hit the film cutter buffer.
- Adjust the arm position by tightening or loosening the bolt of the end stop (3).
- The open position of the film cutter is defined by its buffer link length (4).

Adjusting the film cutter's roll holder (**Fig. 22, 23**)

- The roll holder surfaces (2) in the closed position must be flush with each other.
- The eye of the roll holder in the open position, which connects the roll holder (2) with the link (4), must rest on the end stop (5).
- The roll holder force is to be adjusted by using the nuts (6) to tension the spring on the link.
- The roll holder position is to be adjusted by using a nut (7) to change the link length.

Adjusting the cutting blade (**Figs. 22, 23**)

- The edge of the moving blade (10) in the closed position must be set parallel to the edge of the fixed blade (9).
- In the open position, the angle between the blade edges must be bigger than the angle of the buffer area, so that the film band is not cut too soon when it is pulled to the buffer.
- Use the set screws (8) to set the buffer force of the fixed and moving blades.



DANGER

DANGER!

Exercise particular caution when adjusting the blade. The blade is very sharp. Risk of hand injury.

6.13 Lighting transporting and servicing positions

To avoid any risk of damaging the road lighting during operation, the front and rear lighting are fitted with two brackets, so that resetting them to the service position, where they are out of reach for the moving parts of the Bale Wrapper, is possible.

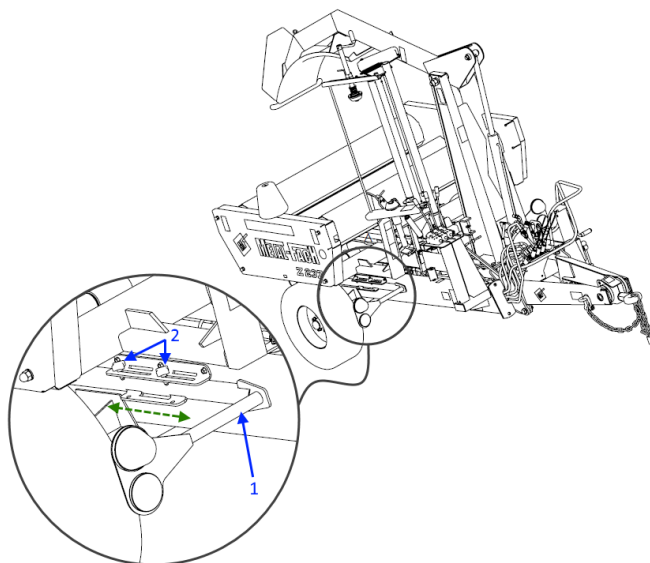

Figure 24. Front-lighting transporting position

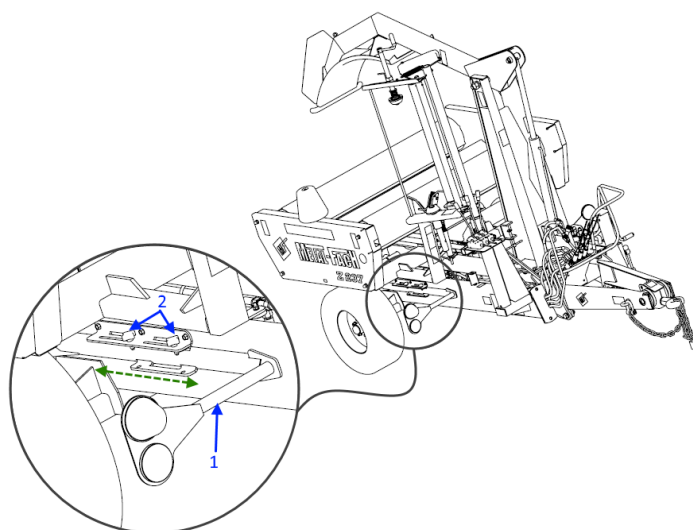

Figure 25. Front-lighting servicing position

Setting the working position of the Bale Wrapper's lighting (**Fig. 24, 25**):

- Loosen the knobs (2) and move the light brackets (1) forward. Use the knob to lock the position.

Preparing the lighting for the transporting position (**Fig. 24, 25**):

- Loosen the knobs (2) and move the light brackets (1) backward. Use the knob to lock the position.

7 Hydraulic system

The Bale Wrapper's hydraulic installation is supplied from the tractor's power hydraulics system. Connecting to the power hydraulic system is done by connecting the hoses supplying the hydraulic distributor and then the hydraulic motor and hydraulic servos (cylinders). The individual hydraulic components are connected to one another with flexible and metal hydraulic hoses.

Depending on the version, the Z237 Bale Wrapper features a power hydraulic system (**Fig. 26**), consisting of the following parts:

- | | |
|---|--|
| 1 – Control levers, | 5 – Working table clamping cylinder, |
| 2 – Hydraulic manifold, | 6 – Lifting and lowering cylinder of the mobile frame, |
| 3 – Choke/non-return valve, | 7 – Lifting and lowering cylinder of the loading arm. |
| 4 – Hydraulic motor for the working table rotation, | |

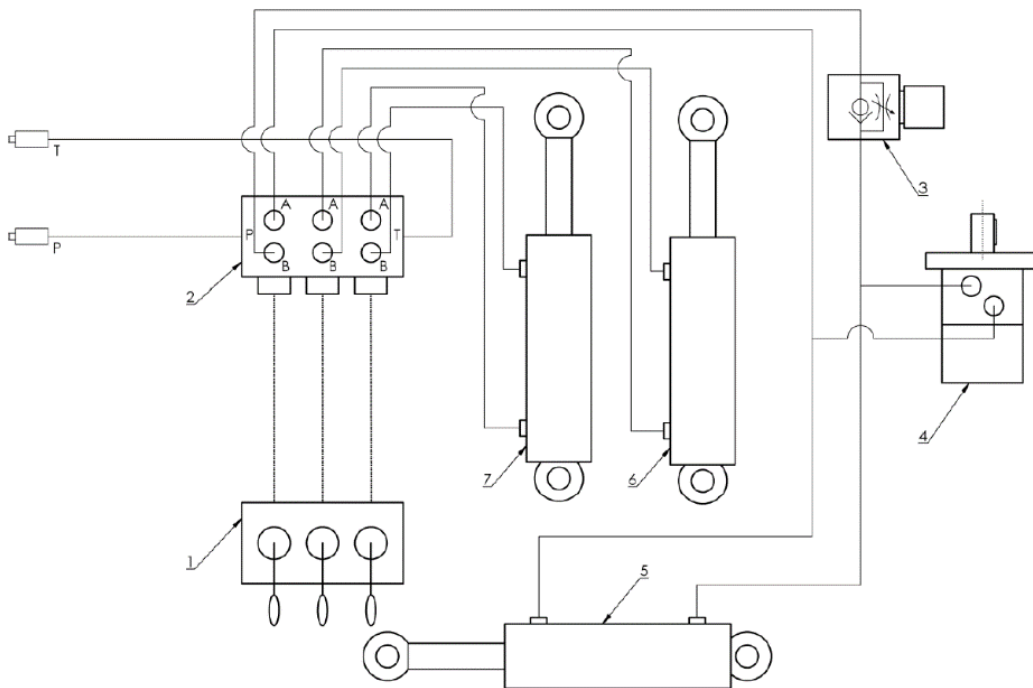

Figure 26. The hydraulic system of the Z237 Bale Wrapper with mechanical film cutter

The control of the hydraulic receivers is carried out via the control-lever panel that is put in the tractor's operator's cab for the time of operation. The control levers are joined with the valves in the hydraulic manifold by means of Bowden cables (two-way action links).

The hydraulic block is protected against too-high pressure in the tractor's power hydraulic system with a pressure valve set by default at 200 bar. The maximum hydraulic oil pressure at which the Bale Wrapper can work is 160 bar.

If the tractor's pump volume of consumption is above 30 l/min, use the tractor's valve to reduce it to 25l/min. If the tractor is not supplied with a flow regulator, have one fitted.



The hydraulic system of the wrapper was factory filled up with L-HL 46 oil type. The tractor's hydraulic system working with the Bale Wrapper must be filled with the same type of oil. Filling up the hydraulic system with oil of another type should be consulted on with the manufacturer of the machine.



CAUTION

CAUTION!

Filling the Bale Wrapper with a different volume of oil consumption from that recommended might result in too-abrupt action by the parts of the machine, fast oil overheating, and eventually damage to the parts of the machine. Use-flow regulators.

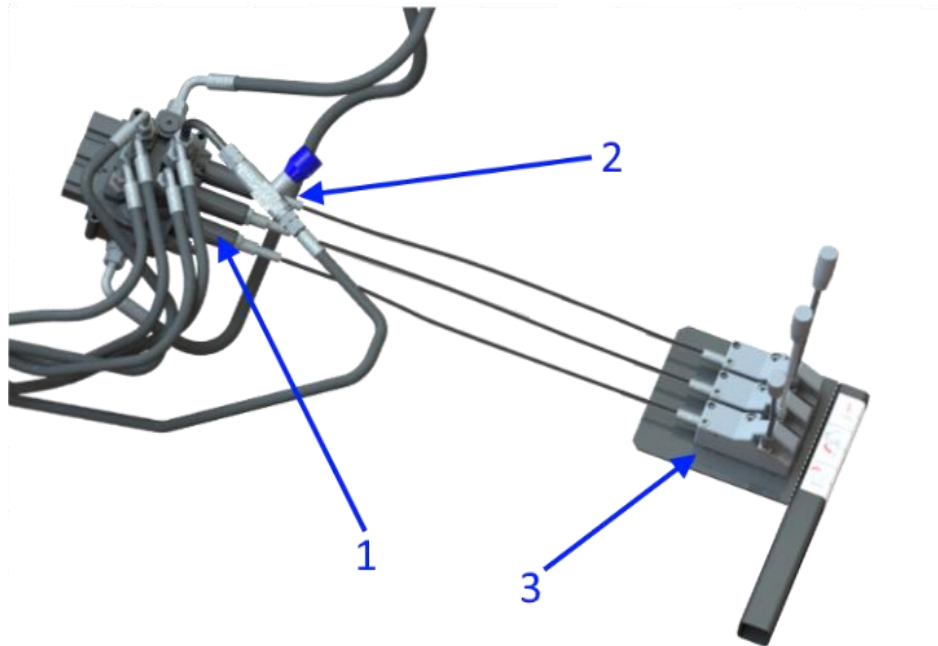

Figure 27. Hydraulic system

1 - 3-section manifold, 2 - valve, 3 - control levers

8 Lighting system

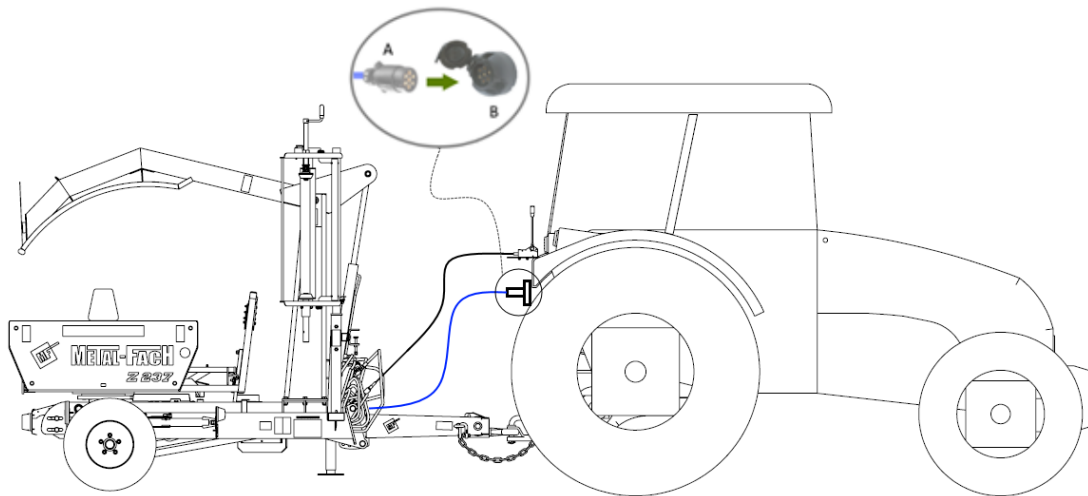

Figure 28. System wiring diagram

The Bale Wrapper is equipped with a 12 V road-lighting system connected to the tractor's system by means of a 7-pin plug, ISO 1724 Type N (**Fig. 28 – A**). The tractor must be fitted with a socket that is suitable for the plug (**Fig. 28 – B**).

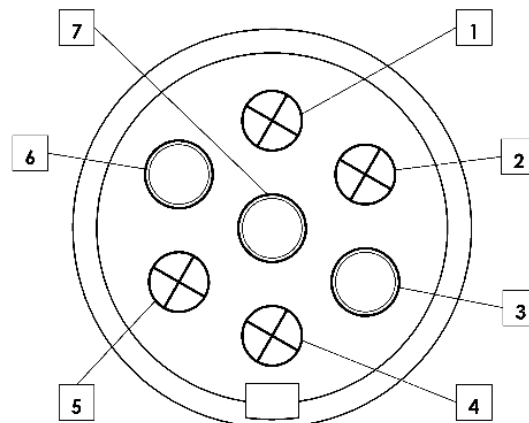

Figure 29. Wrapper-lighting plug (socket side view)

Table 1. Description of the plug lighting wires (**Fig. 29**)

No. of pin	Designation	Circuit description
1	L	Left indicator
2	54G	Fog lights
3	31	Earth
4	R	Right indicator
5	58R	Right-position lamps
6	54	STOP
7	58L	Left-position lamps

9 Lubrication



CAUTION

CAUTION!

All lubrication points should be greased according to Table 2.

The lubrication points are marked on the machine with the pictogram shown in the figure below.

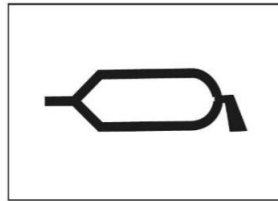

Figure 30. Designation of places for Bale Wrapper lubrication

9.1 Lubrication points

List of parts to be lubricated (**Fig. 31, 32**)

- | | |
|---------------------|----------------------|
| 1 – Pin | 5 – Cylinder bushes |
| 2 – Chain drive | 6 – Thread |
| 3 – Axle gear box | 7 – Film-cutter unit |
| 4 – Rolling bearing | |

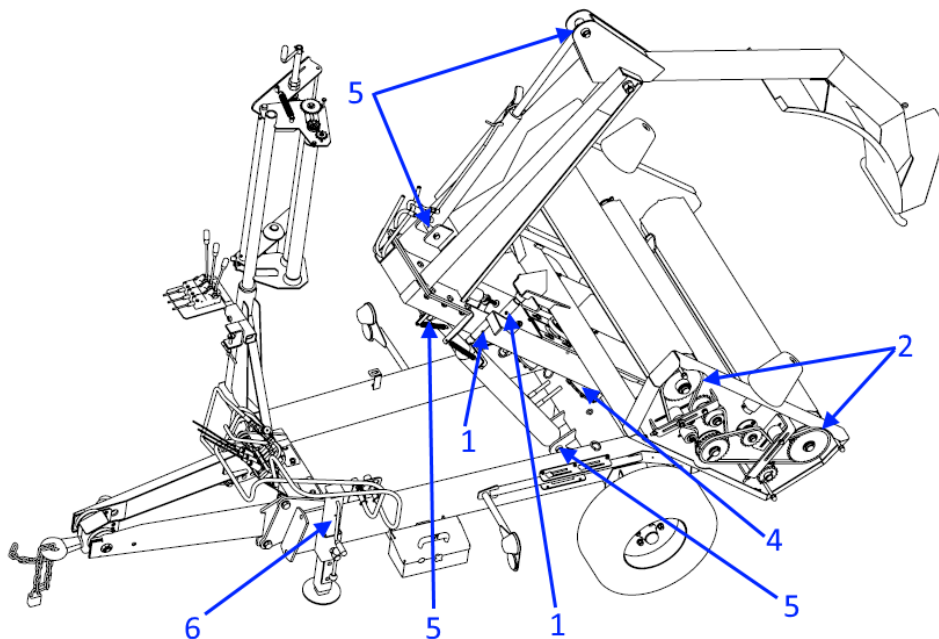

Figure 31. Lubrication points (1)

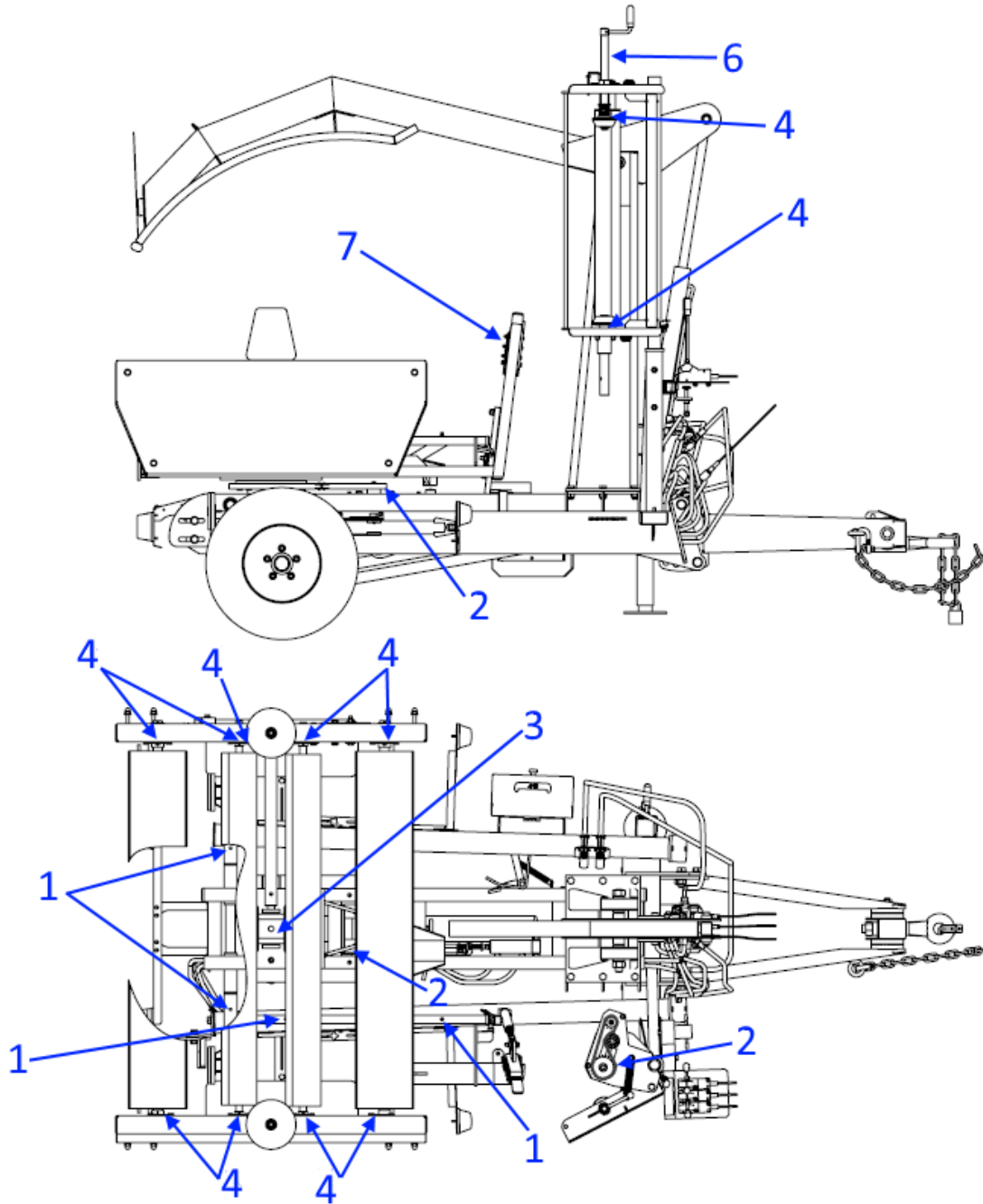

Figure 32. Lubrication points (2)

9.2 Lubrication interval

Table 2. Lubrication-interval table

COMPONENT NAME	LUBRICATION POINT	FIGURE No.	LUBRICATION INTERVAL				NOTES
			Every 10 working hours	Every 50 working hours	Pre-seasonally	Post-seasonally	
Turntable bearings	4	32			•		Grease gun – bearing lubricant
Service-table roller bearings	4	32		•	•	•	Bearing lubricant or lube oil
Film-feeder bearings	4	32		•	•	•	Bearing lubricant or lube oil
Articulation pins of moving parts	1	32, 31		•	•	•	Grease gun – bearing lubricant
Chain drive – service table, roller drive, film-tensioner gear unit	2	32, 31	•		•	•	Oils or grease dedicated for roller chains
Roll holder thread	6	32		•		•	Bearing lubricant or lube oil
Support-foot device thread	6	31			•	•	Grease gun – bearing lubricant
Cylinder bushes	6	32, 31		•	•		Grease gun – bearing lubricant
Film-cutter device – revolution axle	1	32		•	•		Grease gun – bearing lubricant
Film-cutter device – moving articulation	7	31	•		•		Bearing lubricant or lube oil
Film-cutter device – cutting blades	7	31				•	Plant-based oil
Axle gear box (mechanical cutter)	3	32	Refill gearbox oil every 2 years				80W90 gear oil

10 Metric-bolt-tightening torques

Optimised tightening-torque values for bolts or screws and nuts [Nm] are shown in **Table 3**.

Table 3. Tightening-torque values for metric bolts

Bolt-tightening torques – metric bolts in Nm							
Size Ø mm	Pitch mm	Bolt version – strength classes					Wheel nuts, wheel screws
		4.8	5.8	8.8	10.9	12.9	
3	0.50	0.9	1.1	1.8	2.6	3.0	
4	0.70	1.6	2.0	3.1	4.5	5.3	
5	0.80	3.2	4.0	6.1	8.9	10.4	
6	1.00	5.5	6.8	10.4	15.3	17.9	
7	1.00	9.3	11.5	17.2	25	30	
8	1.25	13.6	16.8	25	37	44	
8	1.00	14.5	18	27	40	47	
10	1.50	26.6	33	50	73	86	45
10	1.25	28	35	53	78	91	
12	1.75	46	56	86	127	148	
12	1.50						80
12	1.25	50	62	95	139	163	
14	2.00	73	90	137	201	235	
14	1.50	79	96	150	220	257	140
16	2.00	113	141	214	314	369	
16	1.50	121	150	229	336	393	220
18	2.50	157	194	306	435	509	
18	1.50	178	220	345	491	575	300
20	2.50	222	275	432	615	719	
20	1.50	248	307	482	687	804	400
22	2.50	305	376	502	843	987	
22	2.00						450
22	1.50	337	416	654	932	1090	500
24	3.00	383	474	744	1080	1240	
24	2.00	420	519	814	1160	1360	
24	1.50						550
27	3.00	568	703	100	1570	1840	
27	2.00	615	760	1200	1700	1990	
30	3.50	772	995	1500	2130	2500	
30	2.00	850	1060	1670	2370	2380	

11 Possible faults

Table 4. Possible faults

No.	Fault description	Cause	Method of rectification
1.	Hydraulic oil gets overheated quickly	Insufficient amount of oil in the tractor's system	Ensure the correct oil level in the tractor Replenish the oil
		Volume consumption on the tractor's valve set incorrectly	Reduce the oil-consumption volume in the tractor
		Supply pressure too high	Set a lower supply pressure
		Power hydraulic plugs connected incorrectly	Check the correct connection and condition of the hydraulic plugs
2.	Hydraulic cylinders move too slowly	Insufficient amount of oil in the tractor's system	Check the oil level in the tractor and refill if necessary.
		Volume consumption on the tractor's valve set incorrectly	Reduce the oil-consumption volume in the tractor
		Power hydraulic plugs connected incorrectly	Check the correct connection and condition of the hydraulic plugs
3.	The hydraulic motor and cylinders work too fast and too hard	Too-high pressure in the hydraulic system	Set a lower supply pressure in the tractor
		Too high a volume of oil consumption from the tractor	Reduce the oil-consumption volume in the tractor
		Incorrect manner of Bale-Wrapper control	Follow the recommended method of lever control
4.	One of the cylinders does not move	The system supplying the actuator not tight	Check for possible external leakage
		Damaged cylinder	Contact the dealer
		The rod of the control wire damaged	Contact the dealer

No.	Fault description	Cause	Method of rectification
5.	The loading set cannot lift a bale	Bale weight too high	Try to wrap bales with a weight that meets the use requirements
		The hydraulic-system pressure too low	Raise the pressure of the hydraulic supply to max. 160 bar
6.	The service table tends to rotate when loading	The service table not locked after being stopped	Remember to lock the table before it moves to the unloading position
		The choke/ non-return valve at the hydraulic manifold not adjusted	Adjust the choke/non-return valve on the hydraulic manifold (Section 6.11).
7.	Film is not grabbed	The roll holder set incorrectly	Adjust the roll holder mechanism (Section 6.12)
		The film-feeder setting incorrect	Set the height and angle of the film feeder
8.	Film is not cut	The film-cutting mechanism set incorrectly	Set the film-cutting mechanism (Section 6.12)
		The blade fixed loosely; worn blade	Fix the blade properly; replace the blades
9.	Problems with bale loading, wrapping, and unloading	Unsuitable shape or/and dimensions of the bale	Wrap bales with the correct shape and dimensions given in the Bale-Wrapper characteristics
10.	The film on a wrapped bale is damaged during unloading	Incorrect place of unloading	Unload the wrapped bales only at a place that does not pose a risk of damaging the bale
11.	Improper film coverage of a bale	Too-few layers	Set the correct, efficient number of turntable revolutions for bale wrapping
		Incorrect ratio of turntable roller revolutions to turntable revolutions	Check that a correct double sprocket is fitted for the film width (Section 6.10.1)
		The film-feeder setting incorrect	Set the correct height of the film feeder, release the frame hook in which a film roll is mounted

No.	Fault description	Cause	Method of rectification
12.	Damage and breakage of the film band during wrapping	Damaged surface of the tensioner roller	Rub the roller surface with sandpaper
			Replace heavily damaged tensioner rollers with new ones
		Contaminated surface of the tensioner roller	Clean the roller surface
		Damaged film roll	Use better-quality film that meets the elongation requirement to replace the film roll
			Exercise caution when mounting rolls on the feeder
Tension of the drive chain of the film tensioner too high	Reduce the tension of the drive chain of the film tensioner		
13.	The bale counter does not count revolutions	The distance between the sensor and activating magnet incorrect	Set the correct distance between the sensor and activating magnet
		Sensor wire or plug connecting the sensor with the counter damaged	Check the condition of the sensor wire and plug, contact the distributor

NOTES

A series of horizontal dotted lines for taking notes, spanning the width of the page.

A series of 25 horizontal dotted lines spanning the width of the page, providing a template for handwritten notes or entries.



Metal-Fach Sp. z o.o. is constantly improving its products and adjusting its package to the needs of its customers, so it reserves the right to make changes to its product range without notice. Therefore, before making your purchase decision, please contact an authorised dealer or sales representative of Metal-Fach Sp. z o.o. Metal-Fach Sp. z o.o. will not accept any complaints regarding the data and pictures contained in the catalogue, as the presented range of products does not constitute an offer within the meaning of the provisions of the Civil Code.

The pictures do not necessarily show standard accessories.

Original spare parts are available from authorised dealers, both in Poland and abroad, and also at the Metal-Fach retail outlet.

TECHNICAL SERVICE

16-100 Sokółka, ul. Kresowa 62
phone: +48 85 711 07 80; fax: +48 85 711 07 93
serwis@metalfach.com.pl

SALES

16-100 Sokółka, ul. Kresowa 62
phone: +48 85 711 07 78; fax: +48 85 711 07 89
handel@metalfach.com.pl

SPARE PARTS WHOLESALE STORE

16-100 Sokółka, ul. Kresowa 62

Wholesale:

phone: +48 85 711 07 81; fax: +48 85 711 07 93
serwis@metalfach.com.pl

Retail

24/7 PHONE: +48 533 111 477
Phone: +48 85 711 07 90

YOU CAN FIND UPDATED INFORMATION ABOUT OUR PRODUCTS ON WWW.METALFACH.COM.PL

