



**METAL-FACH**



**MANURE SPREADER "CERBERUS"  
N277/6, N277/7**

**INSTRUCTIONS MANUAL – PART II  
TRANSLATION OF THE ORIGINAL INSTRUCTIONS MANUAL  
REV. II  
OCTOBER 2022**



UE

Instructions Manual No. N277/6\_2-02-167/2013



# Table of Contents

## PART I

INTRODUCTION .....	7
1. Basic Information .....	9
1.1. Introduction .....	9
1.2. Identification of the N277/6 and N277/7 manure spreaders .....	9
1.3. Intended use of the manure spreader .....	12
1.4. Standard equipment .....	13
1.5. Transport .....	14
1.6. Environmental hazards .....	16
1.7. Decommissioning.....	17
2. Safety of use .....	18
2.1. Basic safety principles.....	18
2.1.1. Obligation to provide information.....	18
2.1.2. General principles for work safety and use .....	18
2.1.3. Operating safety .....	18
2.1.4. Working with the machine .....	21
2.1.5. Pneumatic and hydraulic systems .....	22
2.1.6. Working with the PTO shaft .....	23
2.2. Residual risk .....	24
2.2.1. Residual risk description .....	24
2.2.2 Residual risk assessment .....	24
2.3. Warning and information stickers .....	25
3. Design and operation principle .....	30
3.1. Basic technical data .....	30
3.2. Design and operation principle.....	33
3.2.1. The feeding mechanism.....	35
3.2.2. The drive unit of the adapter.....	35
3.2.3. 2-rotor vertical spreading adapter .....	35
3.2.4. Adapter covers.....	36
3.2.5. Ladder .....	36
3.2.6. Load body slide gate .....	38
3.2.7. Main brake system .....	39
3.2.8. Parking brake .....	39
3.2.9. The electrical and lighting systems.....	40
NAME AND ABBREVIATION INDEX .....	44
ALPHABETICAL INDEX .....	45
NOTES.....	48

## PART II

4. Instructions for Use.....	6
4.1 Preparing the machine for operation .....	6
4.1.1 Checking the spreader after Delivery.....	6
4.1.2 Preparing the spreader for the initial start-up.....	6
4.1.3 Changing the Position of the Hitch.....	7
4.1.4 Start-up.....	8
4.2 Coupling and decoupling the spreader.....	9
4.3 Loading the Trailer body .....	14
4.3.1 Loading and Spreading of Lime .....	15
4.4 Fertiliser application rate control and manure spreading .....	16
4.4.1 Adjusting Fertiliser Doses .....	16
4.4.2 Spreading of manure.....	17
4.4.3 Clogging the spreading adapter .....	20
5. Technical maintenance.....	21
5.1 Checking and adjusting the tension of the floor conveyor chains .....	21
5.2 Maintaining the Hydraulic System .....	22
5.3 Gear maintenance .....	23
5.4 Lubrication .....	25
5.5 Pneumatic system maintenance.....	30
5.5.1 System tightness and visual inspection of the pneumatic braking system .....	30
5.5.2 Cleaning air filters .....	31
5.5.3 Draining the air tank.....	32
5.5.4 Changing the flexible connection lines.....	33
5.5.5 Cleaning and maintenance of pneumatic line fittings .....	33
5.6 Maintaining the driving axle and brakes .....	34
5.6.1 Maintaining the driving axle.....	34
5.6.2 Maintaining the brakes .....	35
5.6.3 Tyre Maintenance, Disassembly of the Wheels.....	38
5.7 Maintaining the electrical system and warning components .....	39
5.8 Cleaning, Maintenance and Storage .....	41
5.8.1 Cleaning the Adapter .....	42
5.8.2 Cleaning the load body .....	42
5.9 Tightening torques of screw connections .....	45
5.10 Troubleshooting.....	46
INDEX OF NAMES AND ABBREVIATIONS .....	47
ALPHABETICAL INDEX.....	48
NOTES.....	51

### The symbols used in these Instructions:



DANGER

A hazard warning symbol: This indicates the occurrence of a serious hazard condition that, if not avoided, can result in death or serious injury. This symbol warns against the most-dangerous situations.



CAUTION

This symbol indicates very important information and instructions. Non-compliance can lead to serious damage to the machine, resulting from its incorrect operation.



WARNING

This symbol indicates potential hazards that, if not avoided, can result in death or serious injury. This symbol indicates a lower level of risk of injury than the DANGER symbol.



The symbol indicating useful information.



The symbol indicating service operations that should be performed periodically.


## 4. Instructions for Use

### 4.1 Preparing the machine for operation

#### 4.1.1 Checking the spreader after Delivery

The Spreader is delivered to the User completely assembled and does not require any additional assembly. However, this does not exempt the User from the obligation to check the machine before purchasing and commissioning it.

Before coupling the spreader, make sure that the tractor is suitable for this purpose. The Spreader can only be coupled with a tractor that meets the requirements listed in Table 1.

	<p><b>CAUTION!</b></p> <p>Before coupling and putting the spreader in operation for the first time, it is mandatory to become familiar with the design of the spreader, the layout of its individual components, as well as read and follow the contents of this Operating Instructions and the Operating Instructions dedicated to the articulated telescopic shaft supplied with the machine. The spreader may only be coupled to an agricultural tractor that has a hitching device suitable for connection to single-axle trailers, as well as suitable sockets for the brake, hydraulic and electrical systems. The oil in the tractor's external hydraulic system must be compatible or miscible with the spreader oil.</p>
-----------------------------------------------------------------------------------	-----------------------------------------------------------------------------------------------------------------------------------------------------------------------------------------------------------------------------------------------------------------------------------------------------------------------------------------------------------------------------------------------------------------------------------------------------------------------------------------------------------------------------------------------------------------------------------------------------------------------------------------------------------------------------------------------------------------------------------

CAUTION

Before connecting the machine to the tractor, the operator must verify the technical condition of the spreader and prepare it for the initial start-up. To this end, verify the following:

- the completeness of the machine;
- the condition of the paint coating and mechanical damage to individual components;
- the technical condition of the protective guards and the correctness of their assembly;
- the technical condition of the hydraulic and pneumatic lines;
- the technical condition of the PTO shafts and their guards;
- the hydraulic system and gears for leaks.

#### 4.1.2 Preparing the spreader for the initial start-up

Before starting the trailer for the first time, check the following:

- lubricating points and, if necessary, lubricate the components;
- the correct tightening of screwed connections (road wheels, drawbar, components of the spreading adapter);
- the oil level in the gears of the adapter and the floor conveyor;
- the tensioning of the floor conveyor's chains;
- Make sure that the PTO shaft transmitting power from the tractor has a sufficient length in all possible configurations of the tractor in relation to the machine, when coupled (Figure 17);
- whether the speed of the tractor's PTO shaft matches the required rotational speed of the spreader drive.



CAUTION

**CAUTION!**

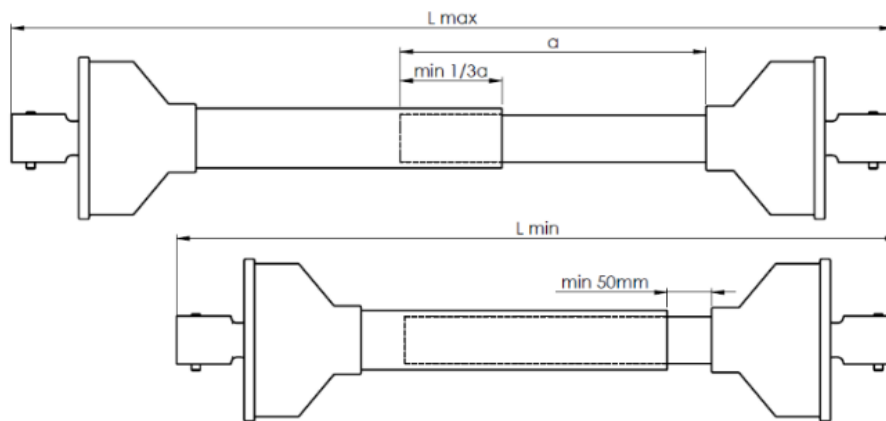
The PTO shaft tubular profiles should overlap by 1/2 the shaft length under normal operating conditions, and 1/3 the shaft length under extreme operating conditions.

Observe the instructions of the shaft manufacturer when fitting the PTO shaft.

If fitted incorrectly, the PTO shaft transmitting power from the tractor can be damaged or destroyed, when driving on an uneven terrain and when cornering.



The PTO shaft can only be adapted to the one type of the tractor that works with the spreader. If the machine is coupled with a different tractor, re-check the correctness of coupling the PTO shaft.

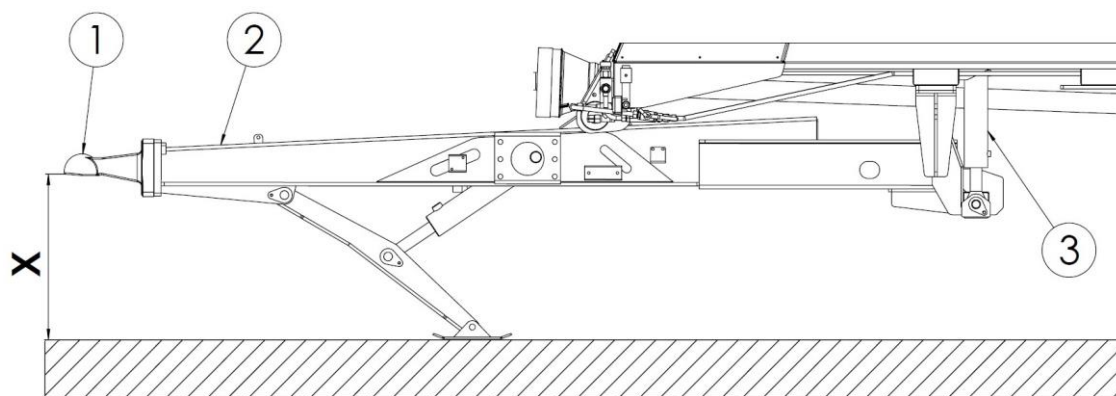


**Figure 17** Adjusting the length of the PTO shaft when the spreader is coupled with the tractor

#### 4.1.3 Changing the Position of the Hitch

The pre-assembled Spreader is designed to be coupled only with the lower hitch of the tractor. The hitch (2) features the function of changing the height of the drawbar eye (1) in relation to the ground – see Figure 18. This is done by the hydraulic cylinder (3). The drawbar is set at the right height by levelling the spreader, which ensures an even distribution of the spreader’s weight on the axle. After coupling the spreader, make sure that it is properly levelled, both with and without load.

See Table 8 for the estimated height ranges between the drawbar eye and the ground.



**Figure 18** Position of drawbar in relation to ground

**Table 8** The estimated range of heights of the drawbar in relation to the ground

Extension of cylinders	min	max
	<b>N277, N277/7 spreader</b>	
Wheel sizes	X [mm]	
650/75 R32	473	811

#### 4.1.4 Start-up

If the preparatory work has been completed and the spreader is in a good working order, couple it with the tractor. After starting the tractor, check the function of each individual system, when parked and unladen. Follow the sequence of actions discussed below to start the machine for the first time:

- 1) Couple the spreader with a compatible tractor hitch.
- 2) Connect the power take-off shaft and secure it correctly.
- 3) Connect the braking, hydraulic, and electrical conduits/lines.
- 4) Lift the parking jack.
- 5) Check the proper operation of the lighting system.
- 6) Release the parking brake of the spreader.
- 7) Start the tractor.
- 8) Check the operation of the main brake, as soon as starting to drive.
- 9) Check the operation of the floor conveyor:
  - connect the power plug of the shift controller to the tractor's power socket, switch on the speed controller,
  - activate the power supply of the floor conveyor using the appropriate lever on the tractor distributor,
  - use the dial to change the controller's setting from minimum to maximum,
  - use the holes in the front guard to observe the movement of the conveyor bars, making sure that its direction of movement is correct;
- 10) check the proper operation of the beater unit shields
  - open and close the adapter unit's guards using the corresponding distributor lever in the tractor (if the guards are installed).
- 11) Start the PTO shaft drive at a low engine speed (start the drive of the adapter rotors).
- 12) Allow the adapter to run at a low engine speed for a few minutes and check whether:



- there is no knocking sound or any other disturbing sounds coming from the drive system and the adapter,
- the adapter rotors rotate smoothly without jamming.

13) Switch off the PTO shaft drive and the tractor engine, and uncouple the spreader from the tractor.



CAUTION

**CAUTION!**

The PTO shaft speeds must correspond to those specified in Table 3.

If all preparatory work has been completed successfully, the spreader can be approved for operation. If any malfunction or faults of individual systems are found during the initial start-up, report them to the point of sale or directly to the manufacturer, to have the problem solved or to carry out repairs.



CAUTION

**CAUTION!**

Failure to follow the recommendations in the operating instruction or starting up the machine incorrectly can result in damage.

Ensure that there are no reservations as to the technical condition of the spreader before it is put into operation.

#### **4.2 Coupling and decoupling the spreader**

The machine may only be coupled with a farm tractor that is in good working order, fitted with all the necessary connections (braking, pneumatic, hydraulic and electric) and a tractor hitch according to the requirements of the spreader manufacturer.

Before coupling the spreader to the tractor, use the parking brake to make sure that the spreader is not moving.



CAUTION

**CAUTION!**

Before coupling the machine, check the technical condition of the tractor and spreader hitch as well as the connection parts of the braking, hydraulic and electrical systems.



CAUTION

**CAUTION!**

Use particular caution when coupling the spreader.

The hydraulic oil in the tractor and spreader must be miscible.

After coupling the spreader to the tractor, secure the braking, hydraulic and electrical lines in such a way that they will not break, wear, bend, crush, or accidentally disconnect, while driving.

For travel and operation, raise the parking jack to its uppermost position, and close the hydraulic valve retaining the foot.

### Coupling the spreader

To couple the spreader, follow the sequence of actions described below:

- 1) Use the parking brake to immobilise the spreader and put the protective chocks under the wheels.
- 2) Align the position of the tractor straight in front of the spreader's hitch.
- 3) Set the drawbar eye to the height that enables coupling the machine:
  - connect the hydraulic lines of the leg to the hydraulic sockets of the tractor's external hydraulic system open the foot's hydraulic locking valve on the drawbar; use the distributor lever in the tractor to raise or lower the drawbar eye to a height that makes it possible to connect it to the tractor's hitch.
- 4) reverse the tractor and couple the spreader to the tractor's hitch. Check the securing pin of the coupling to prevent the machine from accidental disconnecting:
  - if the tractor is fitted with an automatic hitch, make sure that the coupling is completed and the drawbar eye is secured.



DANGER

**DANGER!**

Bystanders are not allowed to stand between the spreader and the tractor during coupling procedure.

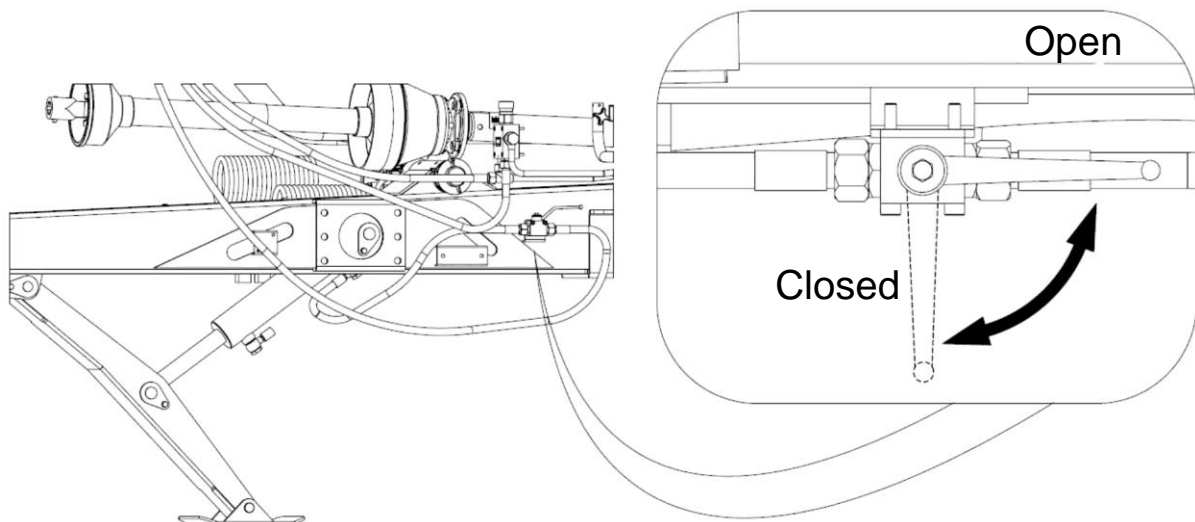
When coupling the machine, the operator of the tractor should exercise particular caution and make sure that no unauthorized persons are in the danger zone.

When connecting the hydraulic lines, make sure that the hydraulic systems of the tractor and Spreader are not pressurised.

Do not use tubes, hoses or other parts of the machine as handrails.

Carrying persons or animals on the machine or tractor is strictly forbidden.

- 5) Use the distributor lever to lift the parking jack to its uppermost position.
- 6) Activate the parking brake in the tractor, switch off the tractor's engine, remove the key from the ignition switch, and secure the tractor against unauthorised access.
- 7) Close the parking jack locking valve (Fig. 19). If the tractor has too few hydraulic sockets for connection of other hydraulic systems, the hydraulic lines of the support leg can be disconnected for travel and operation. When disconnecting the hydraulic lines, make sure that the pressure in the lines is reduced.



**Figure 19** Hydraulic valve to control (shut off) the hydraulic parking jack

- 8) Connect the lines of the 2-line pneumatic braking system; connect the yellow pneumatic line to the yellow pneumatic socket in the tractor, and the red pneumatic line to the red pneumatic socket in the tractor:
- 9) Connect the hydraulic lines of the driving system of the floor conveyor.
- 10) Connect the hydraulic lines of the slide gate system.
- 11) connect the hydraulic lines of the control system controlling the adapter's guards (if present).
- 12) Install the PTO shaft and secure the shields against rotating.
- 13) Release the parking brake of the spreader.



**Manufacture**    **Conductor type**    **Max pressure**    **Date of production**  
(in this case, Q2 2017)

**Figure 20** Marking of the hydraulic lines





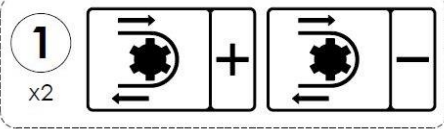
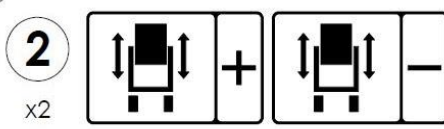
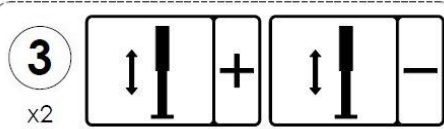
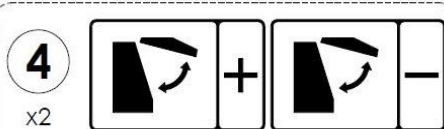
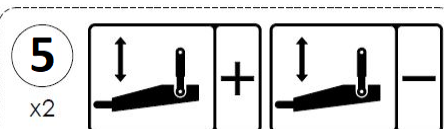
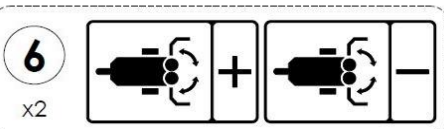
**Figure 21** Identification of the hydraulic line couplings with pictograms to facilitate connection of the line to the tractor (standard) – hydraulics without distributor.



**Figure 22** Pictograms for the control levers of the distributor (distributor control is optional).

The table (9) explains the designations of the pictograms found on the hydraulic lines or on the control levers of the distributor.

**Table 9** Designation of pictograms for hydraulic lines.

No.	Pictograms	Designations
1.		Floor conveyor control
2.		Slide gate control
3.		Hydraulic parking jack control
4.		Rear tailgate control
5.		Drawbar suspension control
6.		Control of adapter covers

### Uncoupling the spreader

To uncouple the spreader, follow the sequence of actions described below:

- 1) Position the spreader on its parking jack, in such a way that the position of the drawbar eye makes it possible to uncouple the tractor safely:
  - Use the tractor's valve block lever to raise the drawbar so that the drawbar eye is in a suitable position to safely uncouple the tractor.
- 2) Activate the parking brake in the tractor, switch off the tractor's engine, remove the key from the ignition switch, and secure the tractor against unauthorised access.
- 3) Stop the spreader using the parking brake and place chocks under the wheels.
- 4) Close the locking valve of the hydraulic parking jack (located directly at the drawbar).
- 5) Release the pressure in each of the hydraulic systems in the tractor.

- 6) Uncouple the hydraulic lines from the floor conveyor, the slide gate, the adapter's guards of the parking jack, and secure them with covers, and then hang the plugs from the holder located on the bracket for cables.
- 7) Disconnect the lines of the braking system.
- 8) Disassemble the power takeoff shaft and secure it correctly
- 9) Uncouple the spreader's hitch from the tractor hitch and move the tractor away.



CAUTION

**CAUTION!**

Use particular caution when uncoupling the spreader from the tractor. Uncoupling the loaded machine from the tractor or leaving the loaded spreader parked and supported on the support leg is not allowed. Dismantling the support leg and supporting the machine on provisional stands is not allowed.

### 4.3 Loading the Trailer body

Before loading, drive and park the correctly coupled tractor and Spreader on a stable, horizontal ground. Park both machines in a straight-ahead position and secure them both with the parking brake.

Before loading, make sure that there are no persons, objects (stones, pieces of wood, etc.) inside the spreader body, that the body gate is fully lowered and that the floor conveyor is not damaged.



CAUTION

**CAUTION!**

For transport and operation of the laden spreader, the front axle load of the tractor must be at least 20% of the tractor weight.


Use suitable loaders, front end loaders or conveyors for loading. Start manure loading at the rear of the spreader body and keep loading in layers. During the loading, empty the bucket smoothly from the lowest possible height. Do not try compacting the manure.

Ensure even distribution of the load to achieve optimum spreading conditions. Due to the differences in the density of the spreading material, using the entire load body capacity can result in exceeding the permissible design load bearing capacity of the spreader. Therefore, observe the permissible gross weight. See Table 10 for the estimated densities of selected materials.

**Table 10** Approximate density of selected materials

Type of Material	Density [kg/m <sup>3</sup> ]
Fermented manure	700–800
Composted manure	800–950
Fresh manure	700–750
Compost	950–1100
Peat	330–650
Agricultural lime	1250–1300

Regardless of the type of material carried, the user is obliged to secure it in such a way that it cannot move freely and pollute the road. If this condition cannot be met, carrying such materials is prohibited.



**CAUTION!**  
It is forbidden to exceed the gross weight.  
An unevenly distributed load causes uneven spreading of the material in the field.

**CAUTION**

#### 4.3.1 Loading and Spreading of Lime

It is allowed to spread loose agricultural lime and its derivatives. Failure to observe the following guidance can result in damage to the spreader.

The general recommendations for spreading agricultural lime:


The maximum weight of loaded lime must not exceed: 8.5 t for the N277/6 and N277/7 spreaders, i.e: 1/2 of the height of the spreader body (0.45 m from the spreader body floor)

- 1) Spread lime immediately after loading, as it can set permanently on the floor of the spreader after a long period of time, which could stop the movement of chains and bars.
- 2) Once loaded with lime, the spreader cannot have any contact with moisture. It is not allowed to start the floor conveyor's drive unit, during precipitation of any kind (unload it manually, if water gets inside the spreader loaded with lime).
- 3) Due to its compaction properties, lime can accumulate in chain links and sprockets. Therefore, regularly inspect the technical condition of all components of the floor conveyor (preferably, after each pass).
- 4) Thoroughly clean the chains, feeder bars, and sprockets, after each spreading of lime (it is recommended to use a pressure washer with clean water or appropriate agents). Washing and drying must be carried out at temperatures above zero.
- 5) Clean all greasy or oily surfaces with extraction naphtha or degreasing agents, and then wash them with clean water mixed with a detergent.

Manure Spreaders are not typically designed for spreading lime and its derivatives. When spreading lime with Spreaders, it is not possible to achieve the optimum spreading



parameters, when compared to lime spreading using machines specifically designed for that purpose.

	<p><b>CAUTION!</b> Strictly adhere to the recommendations provided for lime spreading. Failure to adhere to the rules for lime spreading with the spreader can result in damage to the machine. When spreading lime or derived fertilisers, use suitable protective clothing and PPE, and observe the general regulations for fertiliser application.</p>
-----------------------------------------------------------------------------------	-------------------------------------------------------------------------------------------------------------------------------------------------------------------------------------------------------------------------------------------------------------------------------------------------------------------------------------------------------------------

#### 4.4 Fertiliser application rate control and manure spreading

##### 4.4.1 Adjusting Fertiliser Doses

Dosage of the material spread over a certain area of the field depends on the following factors:

- 1) The speed of the floor conveyor.
- 2) The driving speed.
- 3) The loading height of the load body.
- 4) The effective spreading width, depending on the type of spreading material.

The speed of the floor conveyor should be selected experimentally and set using the dial on the floor conveyor speed controller, Figure - 23, which should be placed in the tractor cab and connected to the tractor's cigarette lighter socket.

##### Adjusting the Speed of the Floor Conveyor:

- To reduce the speed of the floor conveyor: turn the knob of the controller clockwise towards "0",
- To increase the speed of the floor conveyor: turn the knob of the controller anticlockwise towards "10",
- by selecting the appropriate "tortoise" – "hare" operating mode,



**Figure 23** Control panel for adjusting the speed of the floor conveyor.





Low driving speed and high speed of feeding the load result in high doses of fertiliser.  
High driving speed and low speed of feeding the load result in low doses of fertiliser.

**Table 11** Manure application rate (with density of 950 kg/m<sup>3</sup>) depending on the feeding speed of the floor conveyor and the actual work speed for the “tortoise” operating mode.

Setting No.	Conveyor Capacity [kg/s]	The Working Speed of the spreader [km/h]						
		4	5	6	7	8	9	10
		Dose of manure [t/ha]						
2	4.2	5.5	4.9	4.1	3.6	2.8	2.3	1.8
3	6.4	7.2	5.8	4.8	4.1	3.6	3.2	2.9
4	14.3	16.1	12.9	10.7	9.2	8.0	7.2	6.5
5	25.7	29.0	23.2	19.3	16.5	14.5	12.9	11.6
6	38.4	43.2	34.6	28.8	24.7	21.6	19.2	17.3
7	50.1	56.4	45.1	37.6	32.2	28.2	25.1	22.6
8	64.7	72.8	58.2	48.5	41.6	36.4	32.3	29.1
9	76.8	86.4	69.2	57.6	49.4	43.2	38.4	34.6
10	99.5	112.0	89.6	74.6	64.0	56.0	49.8	44.8

#### 4.4.2 Spreading of manure

Before starting to spread manure, re-check the condition of the hydraulic connections and safety guards.



**DANGER**

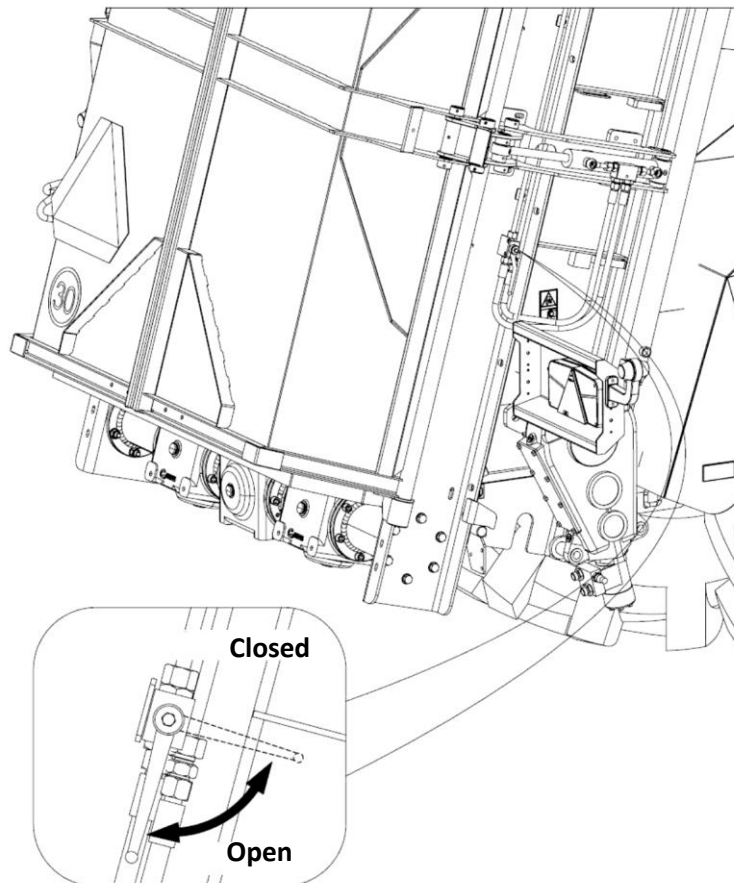
#### **DANGER!**

Operating the spreader with safety guards removed or with a damaged articulated telescopic shaft poses a direct risk to the life and health of the operators.

Bystanders or animals are not allowed to stand in the spreading zone. Keep a safe distance from power lines, especially when working with the slide gate of the load body raised.

Do not operate the PTO shaft at other rotational speeds than the those specified in Table 3. Using different PTO speeds can damage the adapter or its drive.

To limit the spreading action and achieve precise fertilisation of the field at the boundaries, set and lock the right-hand shield of the beater unit in the desired position. Close the hydraulic valve to lock the right-side guard – see Figure 24. The degree of opening the adapter's left-side guard can be adjusted from the driver's position, using the distributor lever, after locking the right-side guard.



**Figure 24** Hydraulic valve locking adapter cover

### The procedure for starting manure spreading

- 1) Set the tractor coupled with the spreader to drive straight ahead at the location where spreading the fertiliser starts.
- 2) Use a proper valve block lever on the tractor to open the beater shields
  - If the lock valve of the right-side adapter's guard is closed, only the left-side guard will open.
  - To limit the spread, open the right-side adapter's guard to the required position, and then lock it with the hydraulic valve. Open the left shield fully or move it to the required position
- 3) Make sure that the PTO shaft of the tractor is adjusted to the correct range of rotational speed.
- 4) Start the PTO shaft at a low engine speed and increase the engine speed, until the adapter rotors have reached the correct speed, and keep it within this range.
- 5) Fully raise the slide gate of the load body.
- 6) Switch on the floor conveyor controller; ensure that the speed control knob is set to the "0" position and the mode switch is set to the "tortoise" position.
- 7) Operate the floor conveyor drive using the correct direction of travel lever, ensuring that the correct direction of travel is achieved (if necessary, switch the direction of travel lever in the opposite direction).
- 8) Adjust the conveyor speed (spread rate) with the control knob, increasing the setting from "0" to "10".

- 9) Engage the tractor gear and start working as soon as the sufficient amount of manure has been fed onto the rotors of the adapter.

#### **End of spreading procedure**

- 1) It is recommended to lower the load body's slide gate to the height of the fed material, in the final phase of spreading.
- 2) In order to achieve an even application rate, the forward speed should be reduced in the final stage of spreading or, using the knob on the controller, the speed of the floor conveyor should be increased and/or the "hare" function should be used for that.
- 3) Switch off the floor conveyor's drive, when the load body is completely empty.
- 4) Fully lower the slide gate in the load body.
- 5) Reduce the rotational speed of the engine and switch off the PTO shaft drive.
- 6) Close the adapter covers.
- 7) Clean the spreader after finishing each spreading, if you intend to drive on public roads, to avoid their contamination.



CAUTION

**CAUTION!**

Strictly observe the sequence provided for starting the spreader. Following any different sequence can damage the spreader and endanger the health or life of the operator.

When driving on headlands, first switch off the drive of the floor conveyor, and the PTO shaft of the tractor.

The direction of movement of the floor conveyor can only be reversed, if the rotors of the adapter are locked. It is not allowed for the load to come into contact with the front panel of the load body, when the load is moving forward.

#### **4.4.3 Clogging the spreading adapter**

When spreading manure, the spreading adapter can get clogged, which stops the rotors of the adapter by shearing the safety pin in the articulated telescopic shaft transmitting power from the tractor to the spreader. If the rotors of the adapter come to a stop during spreading, immediately switch off the drives of both the floor conveyor and the PTO shaft drive in the tractor.

Causes of the adapter's clogging:

- objects such as stones, wood, etc., get into the adapter together with manure,
- the feeding speed of the floor conveyor is too high,
- the rotational speed of the PTO shaft is kept too low,
- inadequate speed of the PTO shaft,
- high density of material.

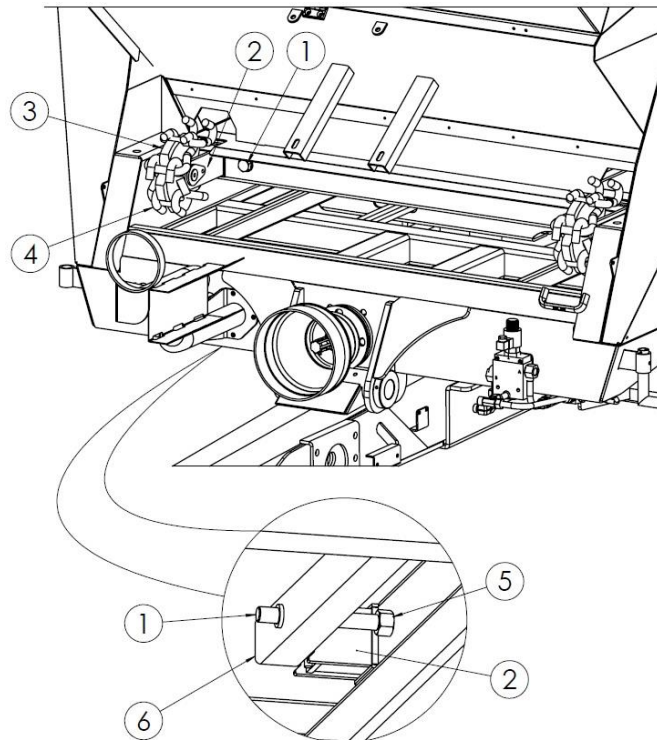
#### **Unclogging the spreading adapter:**

- 1) Switch off the PTO shaft drive and uncouple the PTO shaft from the tractor.
- 2) Reduce conveyor chain tension (VAUCANSON chain only).
- 3) Reverse the floor conveyor by switching the distributor lever in the tractor in the direction opposite to the normal working position of the feeder.
  - perform this action in phases,
  - reverse the conveyor only as much as required for the load not to press on the rotors of the adapter.
  - It is not permitted to move the conveyor forward, when the load is in contact with the front panel of the load body.
- 4) Switch off the tractor's engine, activate the parking brake to stop the tractor and the spreader, remove the key from the ignition switch, and secure the tractor against unauthorised access
- 5) Use suitable tools to remove any objects blocking the rotors of the adapter.
- 6) Install the bolt in the coupling of the articulated telescopic shaft and connect it to the tractor.
- 7) Start the tractor's engine and activate the PTO shaft to clean the adapter's rotors of any residual material.
- 8) Tension the chains of the conveyor.

## 5. Technical maintenance

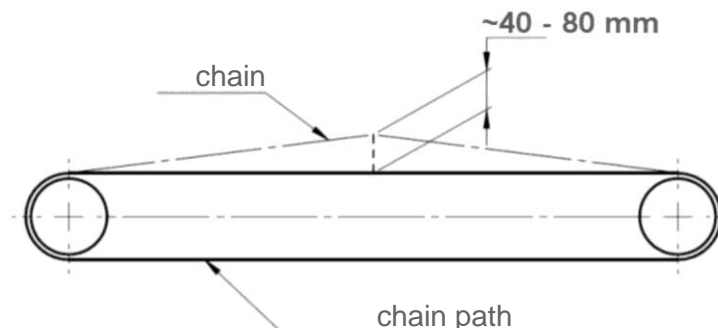
### 5.1 Checking and adjusting the tension of the floor conveyor chains

The tension of the floor conveyor chains during operation must be checked daily, especially during the initial period of operation. Carry out the tensioning of the conveyor chains by adjusting screws (1) at the front of the spreader body - Figure 25. To increase the chain tension, loosen the nut (5) and then tighten the adjusting screws (2) so that the tensioner slider (1) and the pulley (3) move forward. Follow the tensioning procedure for both chains (4), ensuring that their tension is equal. The locking nut (5) should be tightened after tensioning.



**Figure 25** Tensioning the chains of the floor conveyor: 1 – adjustment screw, 2 – tensioner slider 3 – pulley, 4 – conveyor chain, 5 – locking nut, 6 – tension bar

If tensioned correctly, the chain can be raised to a height of 40-80 mm, when applying a force of 60 kg to the chain in the middle of the length of the load body – Figure 26.



**Figure 26** Checking the chain tension in the spreader

If the entire range of adjusting chain tensioning is used up, it is possible to shorten the chain of the conveyor by removing 1 link of the chain at the point of its connection. The reason for an excessive chain stretching may be an incorrect adjustment of the chain's tension.



CAUTION

**CAUTION!**

The conveyor chains must be adjusted to equal tension. If too loose, the chains can damage the spreader and pose a direct risk to bystanders or operators.

**5.2 Maintaining the Hydraulic System**

The hydraulic system of the spreader must be leak-proof. It is not allowed to operate the spreader with a leaking hydraulic system. To check the tightness of the system, activate each individual circuit of the hydraulic system several times. If oil leakage is found, seal the connection or change the leaking line.

**Table 12** Characteristics of the HL-46 hydraulic oil

No.	Name	Value
1	Viscosity grade as per ISO 34448VG	46
2	Kinematic viscosity	41.4 – 50.6 mm <sup>2</sup> /s (40°C)
3	Quality class as per ISO 11158	HL

Each new Spreader has its hydraulic system factory-filled with the HL-46 oil. The oil in the hydraulic system of the tractor should be of the same grade as the oil used in the hydraulic system of the spreader. It is permitted to mix oils of the same grade, provided that it is approved by the oil Manufacturer. The hydraulic system of the spreader is not equipped with a filter, which means that the cleanliness of the oil in the system depends on the condition of the filters in the hydraulic system of the tractor. The correct and trouble-free operation of the hydraulic system depends on the cleanliness of the hydraulic oil.

Keep both the hydraulic quick couplings of the spreader and the hydraulic sockets of the tractor clean. After disconnecting the lines from the tractor, wipe the plugs of quick couplings with a clean and dry cloth, and then secure them with protective caps.



Change rubber hydraulic lines every 4 years, regardless of their technical condition, unless a fault has been found earlier.  
Change the filters and oil in the hydraulic system of the tractor on a regular basis to ensure reliable and stable operation of the hydraulic system of the spreader.



CAUTION

**CAUTION!**

The hydraulic system is under high pressure during operations. Check the tightness of the hydraulic system and the technical condition of the lines on a regular basis, and eliminate any leaks on an ongoing basis.

Use the hydraulic oil recommended by the manufacturer.

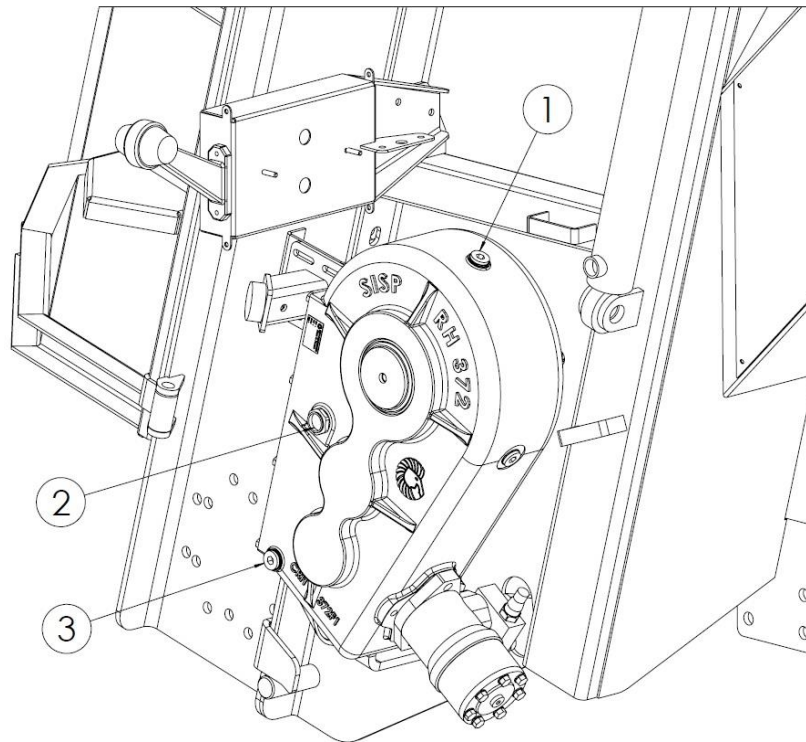
Never mix two different types of oil.

Contaminated oil can cause the failure of hydraulic components.

The oil used in the hydraulic system is not listed as a hazardous substance, but prolonged skin exposure can cause irritation. Use soap and water to wash the skin that has come into contact with oil.

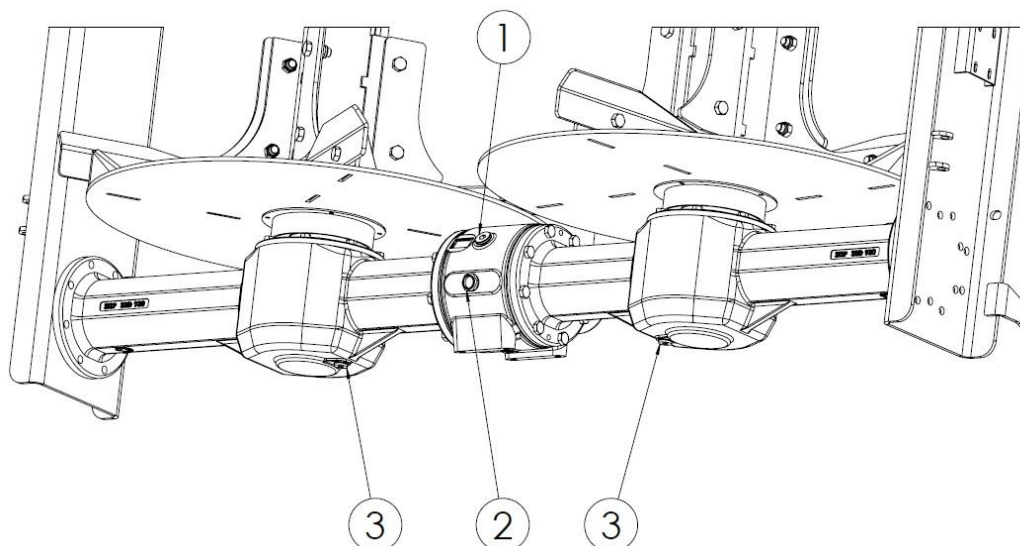
**5.3 Gear maintenance**

Maintenance of the spreader's transmission consists in checking the level of, topping up, and changing the gear oil.



**Figure 27** Oil level check points of the floor conveyor gearbox. 1 – oil inlet (vent), 2 – oil level sight glass, 3 – drain plug






**Figure 28** Oil level check points of the beater unit gearbox. 1 – oil inlet (vent), 2 – oil level sight glass, 3 – drain plugs


Change oil at the operating temperature, immediately after work is completed, when the oil is still hot. Carry out the work by driving the spreader on hardened, level ground. When changing oil, use suitable protective clothing, tools, and tanks. Store waste oil in appropriately marked containers and dispose of it, in accordance with the applicable regulations.

To drain the oil from the gear unit (Fig. 27, 28), unscrew the drain plugs (3). Fill the gearboxes with new oil via the oil filler (1) until oil becomes visible in a sight glass (2). The correct oil level is reached when the oil is visible in the middle of the sight glass.

All elements of the adapter’s transmission body are interconnected, so it only requires using the filler plug and level sight glass in the central body to top up and check oil level in the entire unit.



Check the oil level in the beater unit gearbox and the floor conveyor gearbox via a sight glass each time before you start the machine.



Change the oil in the adapter gearbox and floor conveyor gearbox after the first 50 hours of operation and then every 700 hours of operation, but at least every 2 years.

**Table 13** Oil quantity in the gearbox

Name	Type of oil	Volume
The adapter gear	Hipol GL 4 80/W90	12 L
The floor-conveyor gear	Hipol GL 4 80/W90	4.3 L





DANGER

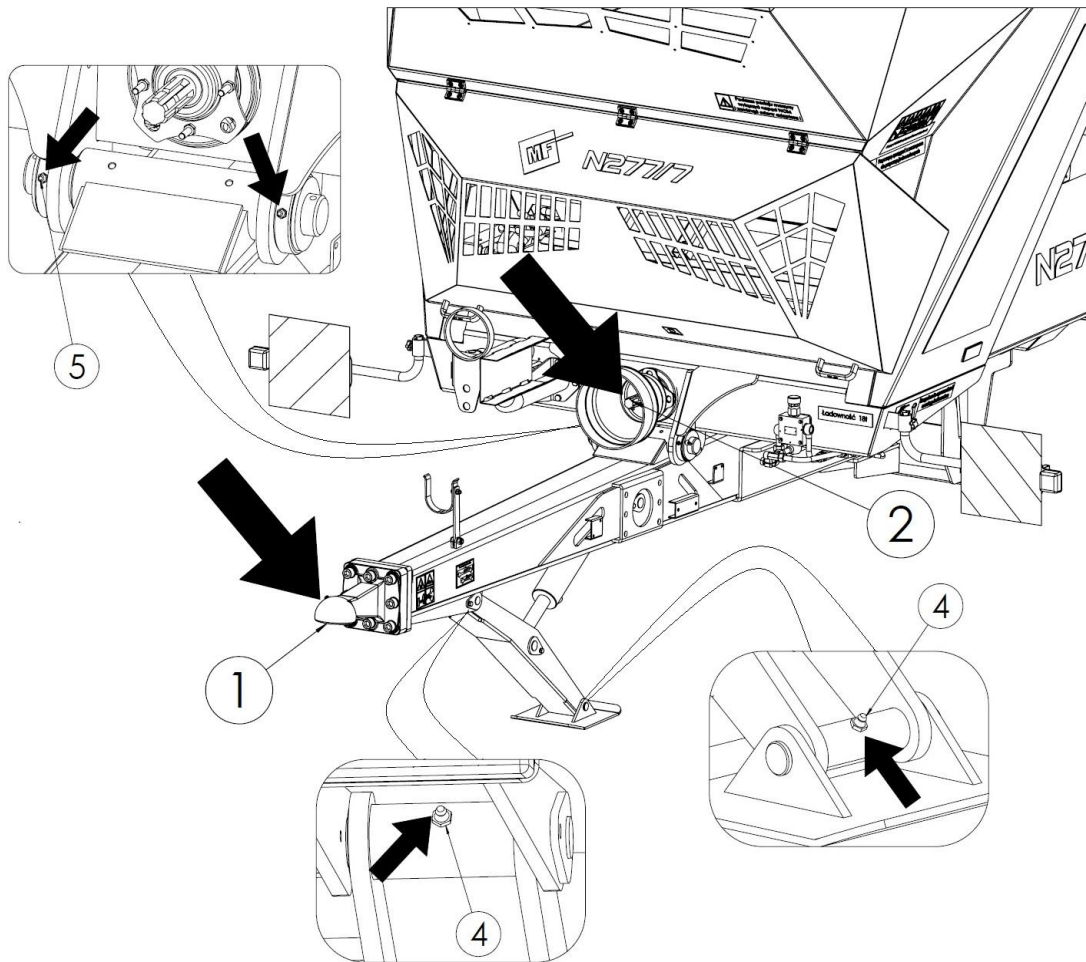
**DANGER!**

During the oil change, use appropriate personal protective equipment such as safety clothing, gloves, glasses and footwear.  
 Avoid contact with skin.  
 Oil may cause an allergic skin reaction.  
 The oil has a harmful long-term effect on aquatic species.

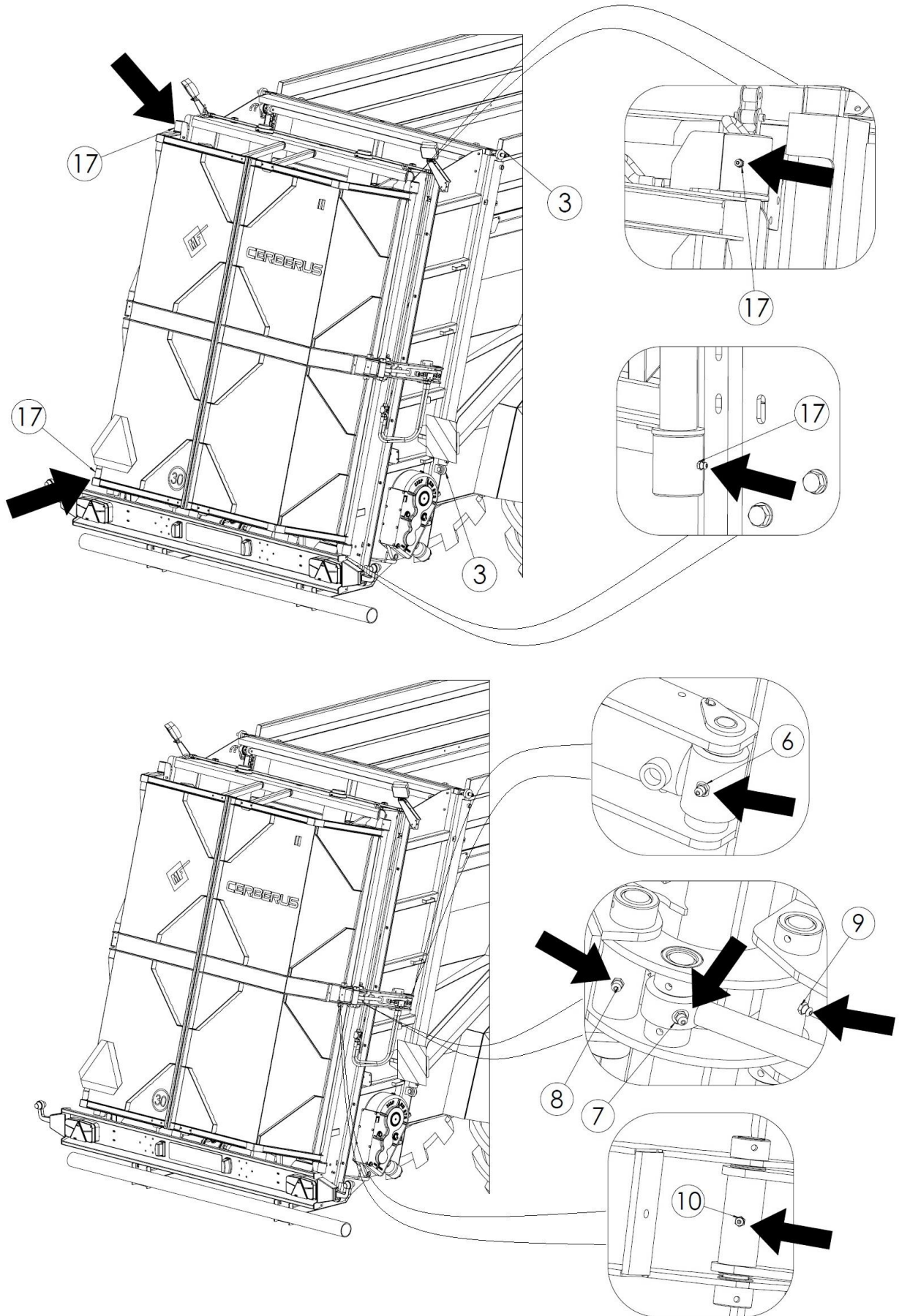
**5.4 Lubrication**

Proper lubrication is one of the most important factors that determine the efficient operation of each individual unit and the mechanisms of the spreader.

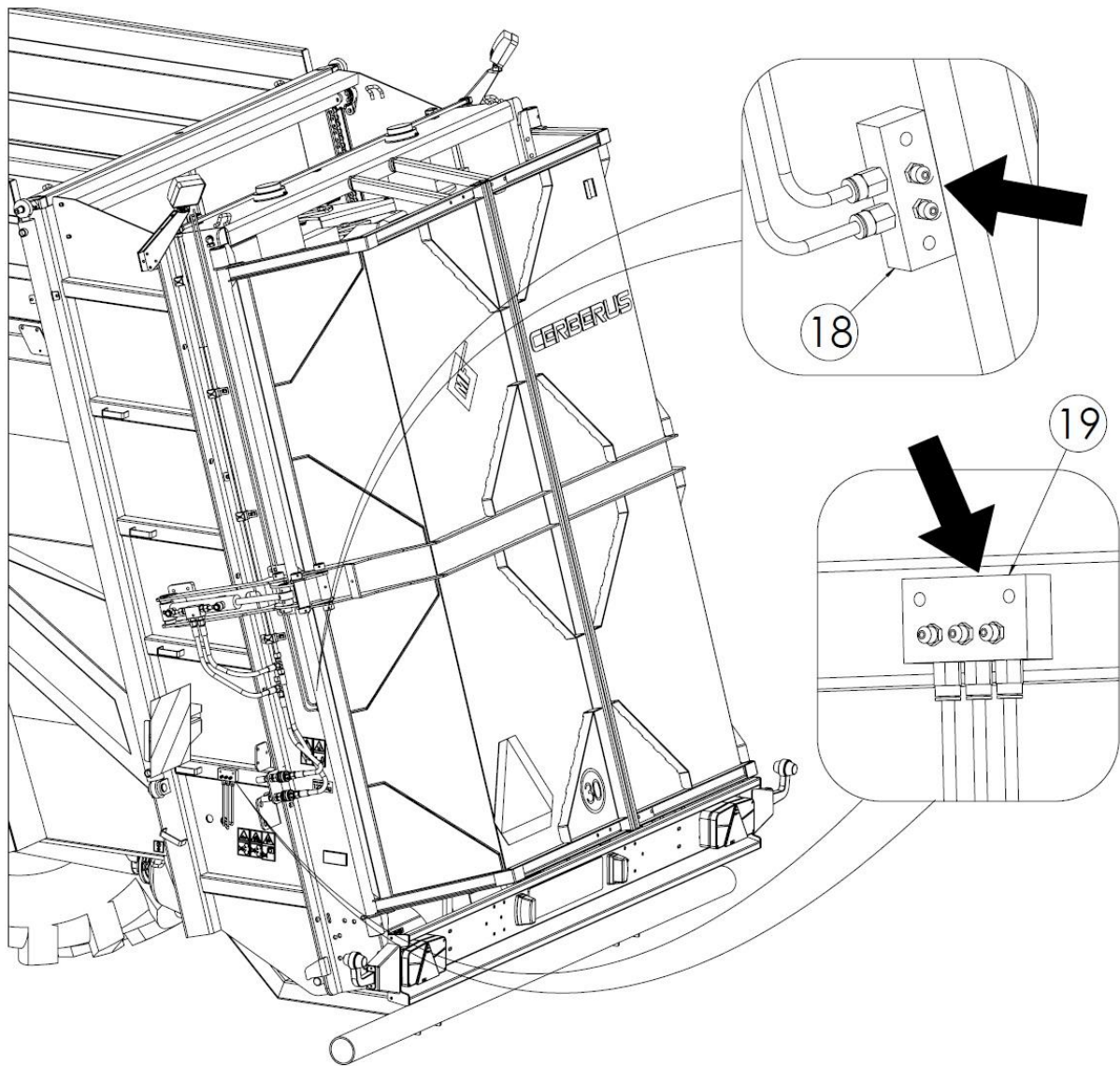
Compliance with the manufacturer's lubrication recommendations significantly reduces the possibility of damage or early wear and tear of individual parts. Lubrication points are indicated in Figures 29, 30, 31 and 32a, while the lubrication schedule is defined in Table 14.



**Figure 29** Lubrication points

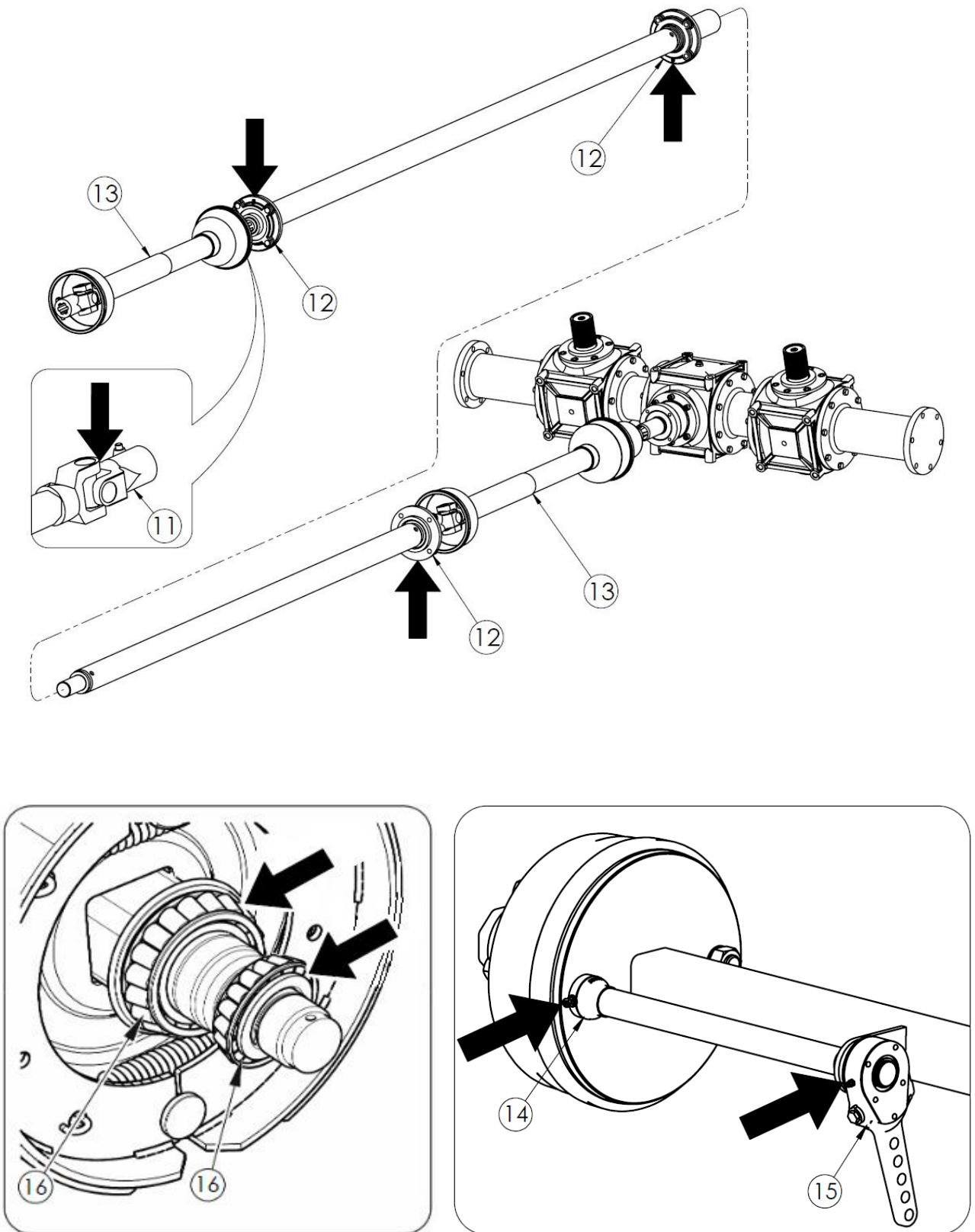


**Figure 30** Lubrication points



**Figure 31** Lubrication points





**Figure 32** Lubrication points.

**Table 14** Lubrication schedule

No.	Name of mechanism	Number of lubricating points	Grease type	Interval
1.	Drawbar eye	1	ŁT	2D
2.	The splines of the shaft of the drive system	1	ŁT	6M
3.	Spherical plain bearings of the gate cylinder	4	ŁT	6M
4.	Pins of the scissor support foot	2	ŁT	6M
5.	Drawbar pin	2	ŁT	24H
6.	Articulated bearing of the adapter cover actuator piston	2	ŁT	6M
7.	Articulated bearing of the adapter cover actuator piston rod	2	ŁT	6M
8.	Guard-opening mechanism connector	2	ŁT	8H
9.	Guard actuator bracket	2	ŁT	8H
10.	Guard connector	2	ŁT	8H
11.	Shaft universal joints	4	ŁT	24H
12.	Bearings of the drive unit	3	ŁT	6M
13.	Articulated telescopic shafts	*	*	*
14.	Sleeves of the expander shafts	2	ŁT	6M
15.	Lever of the brake expander	2	ŁT	6M
16.	Bearings of the wheel hub	4	ŁT	24M
17.	Pins of the scissor support foot	2	ŁT	6M
18.	Upper bearings of the adapter	2	ŁT	8H
19.	Feeder shaft sleeves	3	ŁT	8H

\* - Observe the guidelines provided in the operating instruction supplied with the PTO shaft

Lubrication interval codes: H - working hour, D - working day, M - month

When lubricating, follow the guidelines below:

- Clean the grease nipple before you start pumping the grease
- pump grease, until fresh grease appears in the slots (through which used grease is squeezed out during pumping); after finishing lubrication, leave a little grease on the nipple head.

**Table 15** Lubricants

Codes from Table 10	Description
ŁT	ŁT-42, ŁT-43 General purpose grease
OM	Machine oil

Use a clean cloth to wipe the parts to be lubricated with machine oil, and then apply a small amount of oil to the lubricated parts. Wipe off excess oil.

To lubricate the bearings of the wheel hubs, disassemble the hub, remove used grease, and apply fresh grease. Each time when changing grease, assess the condition of the bearings and change them, if necessary. After mounting the hub, adjust the bearing play.



CAUTION

**CAUTION!**

Driving the spreader without hub caps is not allowed. Dirt entering the wheel bearings causes damage to the wheel bearings.

## 5.5 Pneumatic system maintenance

Have the pneumatic braking system components repaired, changed and refurbished by professional workshops that have all appropriate qualifications and tools to perform this type of work.

Maintaining the pneumatic system carried out by the User is narrowed down to:

1. Checking the air-tightness of the system and its visual inspection
2. Cleaning the air filters.
3. Draining the air tank and cleaning the drain valve.
4. Changing the flexible connection lines.
5. Cleaning and maintaining the connections of pneumatic lines.



CAUTION

**CAUTION!**

It is not allowed to operate the spreader if the brake system is faulty.

### 5.5.1 System tightness and visual inspection of the pneumatic braking system



System tightness and visual inspection:

- At start-up
- after the first 1,000 km
- each time system components are repaired or replaced
- annually

Checking the tightness of the pneumatic system:

- Couple the tractor with the spreader
- use the parking brake to immobilise the tractor and the spreader, and put chocks under the wheel of the spreader,
- start the tractor's engine to supply air to the braking system of the spreader,

- switch off the tractor's engine,
- check the air-tightness of the pneumatic components after releasing the brake pedal in the tractor,
- check the air-tightness of the pneumatic components when the brake pedal in the tractor is pressed (it is required to have another person to assist you).

If leaking, air will escape outside with characteristic hissing at damaged places. Minor leaks can be detected by putting a layer of a foaming agent on to an inspected part (dish washing liquid, soap).

Change the damaged parts or have them repaired. Eliminate any leaks in the joints by tightening the joint or changing the fitting or sealing.

When checking the air-tightness of the system, carry out a simultaneous visual inspection of the pneumatic braking system. Pay particular attention to the condition of the pneumatic lines, the manner of their fastening, as well as their cleanliness and completeness. Lines must not show any signs of wear, permanent deformation, partial splitting or bending. It is not allowed for the system's components to be contaminated with oil and grease.



CAUTION

**CAUTION!**

Have the pneumatic system components repaired, replaced and refurbished by professional workshops only.

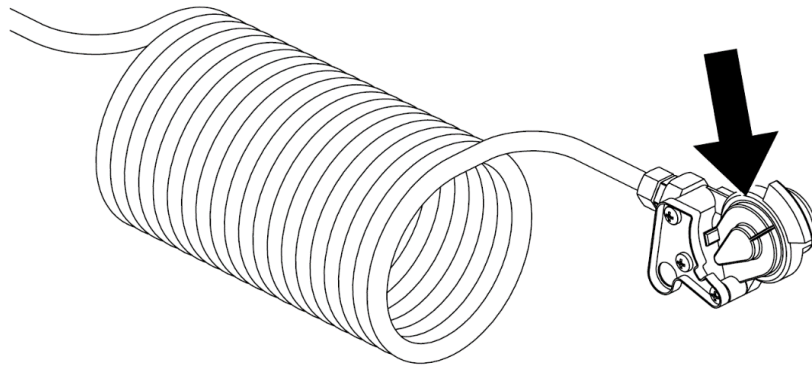
### 5.5.2 Cleaning air filters



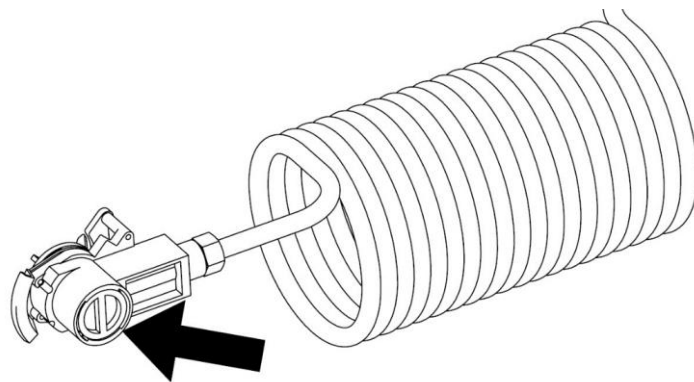
DANGER

**DANGER!**

Depressurise the spreader's brake system before dismantling the filters.



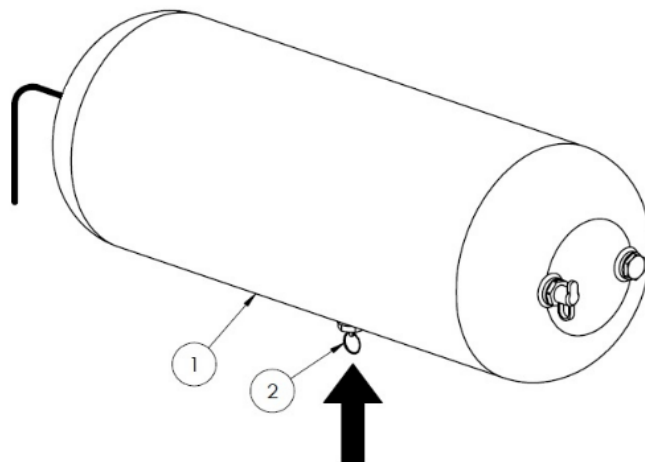
**Figure 33** Brake system air filters located on the inside of the port



**Figure 34** Brake system air filters located on the outside of the port

Clean the air-filter elements, according to their operating conditions, but at least every 6 months. The filters located in the fittings of pneumatic lines - see Figures 33 & 34. The air filter elements are reusable and it is not required to change them, unless damaged.

### 5.5.3 Draining the air tank



**Figure 35** Air tank drainage: 1 – air tank, 2 – drainage valve





Drain the air tank, after every 7 days of use.

Air tank drainage – Figure 35:

- Pull the drain valve (2) to let water escape (compressed air will make water escape outside)
- release the stem of the drain valve (the valve will close automatically and cut off the airflow).

If the drain valve is leaking, it must be dismantled and cleaned or changed, if necessary.

#### 5.5.4 Changing the flexible connection lines

Change all flexible connection lines every 5 years, unless damage (permanent deformation, wear, or cutting) has been found earlier.

To change the lines, do the following:

- purge the system completely,
- unscrew the pneumatic fittings from the lines,
- unscrew the flexible lines from the brake valve,
- fit new lines,
- check the air-tightness of any new connections.

#### 5.5.5 Cleaning and maintenance of pneumatic line fittings



DANGER

**DANGER!**

Faulty, damaged or dirty air line fittings can cause malfunction of the brake system.

If the connections of pneumatic lines show any signs of damage, change them for new ones and fully efficient parts. If exposed to oils, petrol, greases, etc., gaskets in the connections can be damaged or age prematurely.

If the spreader is uncoupled from the tractor, the connections must always be protected with caps and placed in the appropriate holders. It is recommended to preserve the gaskets in the connections with a suitable agent, e.g. silicone spray for rubber parts, after the season is over.

Before each coupling of the machine, check the technical condition of the pneumatic connections in the spreader and the tractor. Keeping the connections clean extends their service life and ensures the correct operation of the entire braking system.



Always check the technical condition of the pneumatic connections, before coupling the spreader with the tractor.

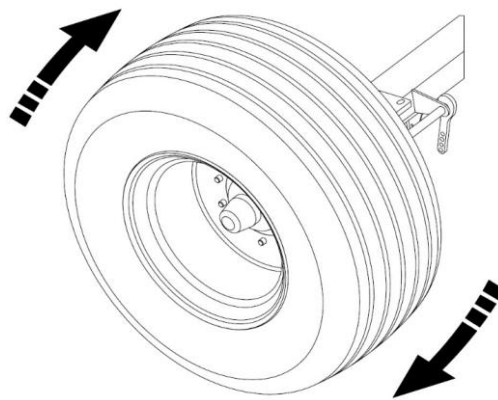
## 5.6 Maintaining the driving axle and brakes

### 5.6.1 Maintaining the driving axle

It is recommended to check the bearings of the driving axle for play - see Figure 36. Carry out this inspection on a newly purchased machine, after the first 100 km. Then, after driving about 1,500-2,000 km, carry out the same inspection again and adjust, if necessary.

To adjust the bearing play, follow the procedure below.

1. couple the spreader with the tractor and engage the parking brake in the tractor.
2. Lift one side of the spreader, so that the wheel does not touch the ground, and secure it against falling.
3. If the wheel shows excessive play, remove the hub cap and the securing pin that prevents the castellated nut from spontaneous unscrewing
4. Turn the wheel while simultaneously tightening the castellated nut, until the wheel has stopped completely.
5. Loosen the nut by  $1/6 \div 1/3$  of a turn, until the nearest pin groove overlaps with the hole on the hub spigot
6. Secure the nut with a new safety pin; replace and fasten the hub cap.



**Figure 36** Checking wheel bearing play

If the bearing play is adjusted correctly, the wheel should rotate smoothly, without hesitation or evident resistance (other than the friction of the brake shoes against the drum). Slight friction of the shoes against the drum, particularly in a new Trailer, or after their replacement, is a typical occurrence. After driving for a few kilometres observe how the wheel hubs heat up, to check finally if the bearing-play adjustment is correct. In addition to the improper adjustment of the bearing play, considerable resistance to wheel rotation and hub heating can be caused by impurities in the lubricant or bearing damage. The afore-mentioned symptoms make it necessary to disassemble the wheel hub to eliminate the malfunction.

### 5.6.2 Maintaining the brakes

After purchasing the spreader, the User must carry out a general inspection of the braking system on the driving axle, and then repeat it periodically.

Have brake components repaired, changed, and refurbished by professional workshops with all the appropriate and tools to perform this type of work.

The User is responsible for carrying out the following maintenance of the driving axle brake:

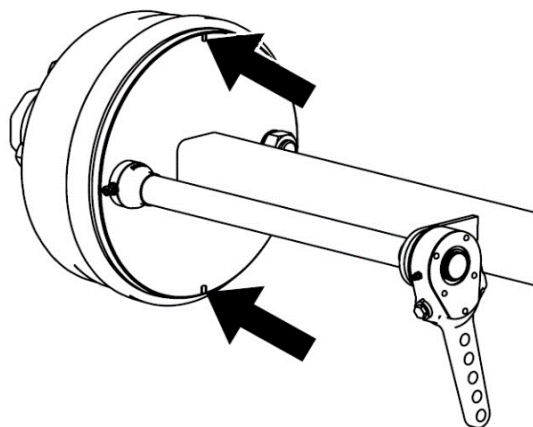
- functional checks of the brakes,
- inspections of the brake-linings for wear,
- adjusting the service brake,
- functional check of the parking brake,

#### Functional checks of the brakes:

- couple the spreader with the tractor and place chocks under the tractor wheels,
- check the manner of fastening the pneumatic cylinder and its forks on the brake lever arm,
- check the axle brake components (pins, cotter pins, nuts, etc.) for completeness,
- activate and release the main brake, and repeat the same with the parking brake (the action of the brakes should be smooth and they should retract without resistance or jamming),
- check the stroke of the cylinder piston rod,
- check the pneumatic cylinders for air-tightness,
- carry out a test run, when unladen, by activating the main brake several times to check its functioning.

#### Inspections of the brake linings for wear

Look through the inspection windows in the brake drum cover to check the brake linings for wear - Figure 37. Replace the brake shoes when the brake lining thickness drops below the minimum value specified by the manufacturer.



**Figure 37** Brake lining wear check



The minimum thickness of brake lining is 5 mm.



Inspections of the brake linings for wear:

- every 3 months of operation,
- if the stroke of the cylinder piston rod takes significantly longer than normal,
- or if any strange noises are coming from around the brake drum.

### Adjusting the service brake

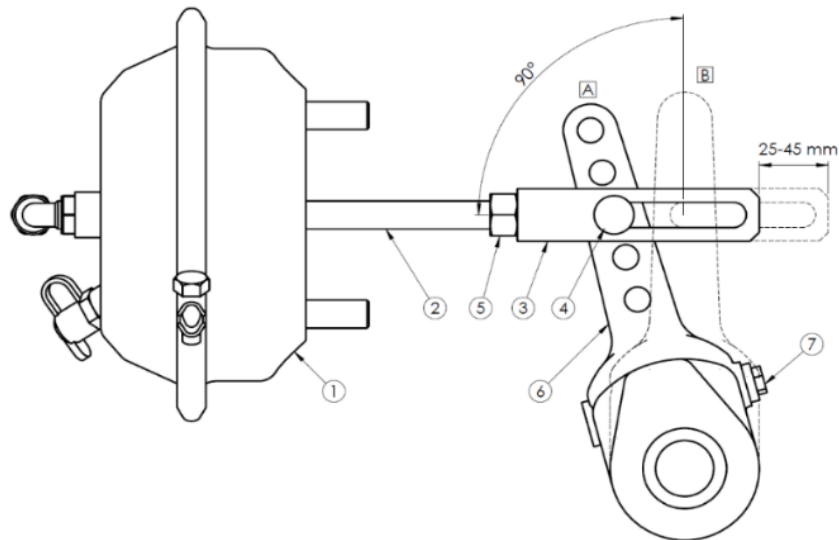
As the brake linings wear, the work stroke of the pneumatic cylinder piston rod increases. Excessive stroke may reduce the effectiveness of the brakes, therefore check, and adjust if necessary, the work stroke of the brake to keep it within the specified operating range. In a brake that is adjusted correctly, the angle between the piston rod and the expander lever in the braking position shall be 90° - Figure 38.

To check the functioning of the brake, measure the stroke length of the piston rod in each pneumatic cylinder. If the stroke of the piston rod is longer than the maximum value (45 mm), the system must be adjusted.

Adjust the stroke of the cylinder piston rod and the angle of the expander lever, by correctly setting the cylinder forks (3) and adjusting the stroke with the adjusting screw (7). Carry out this adjustment for both the cylinder and the expander lever, maintaining the same set values.



The correct stroke of the piston rod should be in the range of 25-45 mm.



**Figure 38** Adjusting the main brake: 1 – pneumatic cylinder, 2 – cylinder's piston rod, 3 – cylinder's forks, 4 – fork's pin, 5 – fork's lock nut, 6 – expander lever, 7 – adjusting screw: (A) The lever position when releasing the brake, (B) The lever position when activating the brake



Checking the technical condition of the brake:

- after the first 100 km,
- every 6 months
- after each repair of the brake system
- if braking action of the spreader wheels is uneven



CAUTION

**CAUTION!**

Improperly adjusted brakes can cause the brake shoes to rub against the drum, which can result in faster wear of the brake linings and/or overheating of the brake.



CAUTION

**CAUTION!**

Mounting positions of the pneumatic brake cylinder in the holes of the bracket and fork pin of the cylinder in the holes of the expander lever are set by the manufacturer and any change of their position is prohibited.

### Parking brake adjustment

Proper operation of the parking brake requires effective brakes and the correct adjustment of the piston rod stroke of the membrane-spring actuators of the first travel axle.



Check and/or adjust the parking brake:

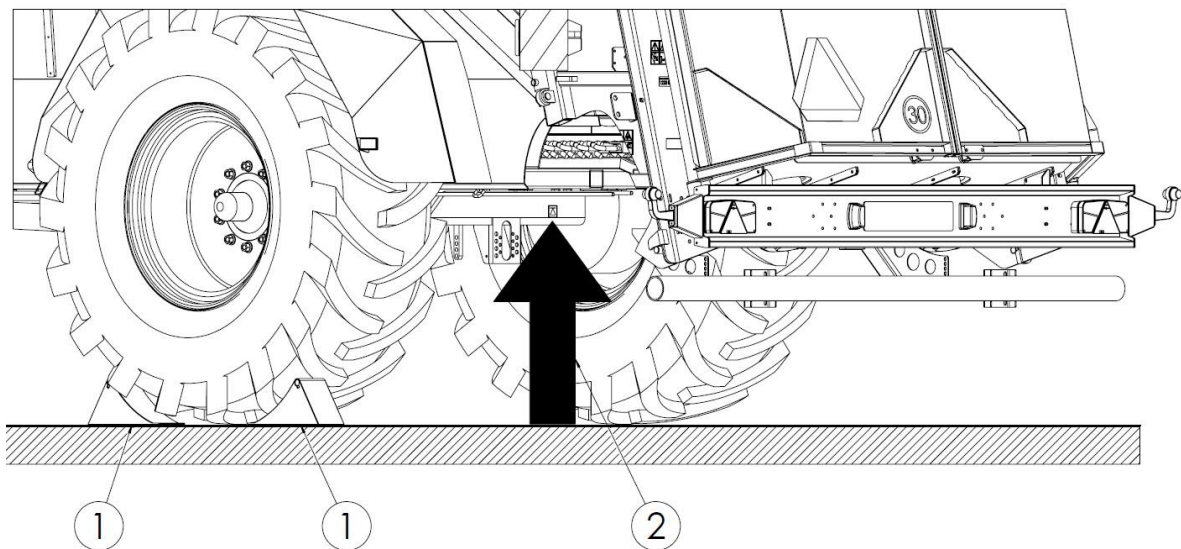
- every 12 months,
- if required.

Parking brake adjustment, should be carried out if:

- exceeding the allowable piston rod travel of membrane-spring actuators,
- damage to membrane-spring actuators,
- after repairing the mechanism of the driving axle brake,

### 5.6.3 Tyre Maintenance, Disassembly of the Wheels

Secure the machine with the parking brake and the wheels with chocks, when maintaining the tyres. Changing the wheel is only permitted, if the load body is empty. Use suitable tools to repair the wheels. The person carrying out the repairs should be trained in such operations, as maintaining and repairing of tyres involves some risk. It is recommended to check the tightness of the nuts, before the initial start-up, after the first laden drive, and then after each intensive use of the machine, after every 100 kilometres. Repeat these inspection activities after each disassembling of the wheels.



**Figure 39** Jacking points 1 – chocks, 2 – jack

If it is necessary to disassemble the wheel, observe the jacking points (2) under the axle. See Figure 39 for the jacking points. Place the protective chocks (1) under one wheel only.



Regularly check the air pressure. Maintain the recommended air pressure. The correct pressure value is indicated on the tyre or as a sticker on the spreader.



**CAUTION!**  
Inspect the tightening of the wheel nuts regularly.  
M18x1.5 = 270 Nm, M20x1.5 = 350 Nm, M22x1.5 = 475 Nm.

CAUTION

- Regularly check and maintain the correct tyre pressure, as recommended in the operating instruction and/or the information provided on the tyre.
- Do not exceed the permissible load capacity of the tyres, according to the operating instruction and/or information provided on the tyre.
- Do not exceed the permissible speed of the spreader, according to the operating instruction and/or information provided on the tyre.
- Secure tyre valves with protective caps.
- If work continues for the whole day, regularly check the temperature of the tyres and, if they heat up, take 30-minute breaks to cool them down.
- Avoid excessive bumps, inconsistent manoeuvres and high speeds when cornering.
- Regularly check the condition of the tyres and replace them if cut or damaged.



**CAUTION!**  
Do not exceed the permitted transport speed, working speed and load capacity of the spreader.

CAUTION

## 5.7 Maintaining the electrical system and warning components



**CAUTION!**  
The electric system of the spreader is supplied with 12 V voltage.

CAUTION

The user's responsibilities related to maintaining the electric system include:

- technical inspection of the electrical system and retro-reflectors
- replacement of light bulbs

Have the components of the electrical system repaired or refurbished by professional workshops having all appropriate qualifications and tools to perform this type of work.



CAUTION

**CAUTION!**

It is not allowed to drive when the lighting system is in an usable condition. Damaged lamp covers and burnt out bulbs must be immediately replaced before starting to drive. Replace damaged or lost retro-reflectors.

Before driving on a public road, make sure that the lighting and retro-reflectors are not dirty.

Maintenance work:

- check the condition of the electrical connecting cable and the socket in the spreader,
- check the lighting system for completeness, technical condition and correctness,
- check all retro-reflectors for completeness and technical condition,
- check for the correct installation of the indicating plate for slow moving vehicles installed in the bracket,
- before driving on a public road, make sure that the tractor is equipped with a retro-reflective warning triangle,
- before driving on a public road, make sure that the lights and retro-reflectors are not dirty.

**Table 16** Light bulb list

Lamp	Type of lamp	Bulb identification/number	Number of lamps
Rear-light cluster, right	MD-33 LZT204	P21/5W / 1 item P21W / 1 item	1
Rear-light cluster, left	MD-33 LZT206	P21/5W / 1 item P21W / 1 item	1
Marker lamp, right	LO 355	C5W / 1 item	1
Marker lamp, left	LO 355	C5W / 1 item	1
Front running light, right	LO 093	W5W / 1 item	1
Front running light, left	LO 093	W5W / 1 item	1
Licence plate light	EMA-3	C5W / 1 item	1



Check the electrical system:

- each time the spreader is coupled.



The Spreader lights are equipped with replaceable bulbs. If it is required to change the bulbs, remove the lens and change the bulbs to new ones with the same power rating and marking as the original ones. See Table 16 for a list of bulbs used in the spreader lights.

### 5.8 Cleaning, Maintenance and Storage

It is recommended to clean the spreader thoroughly of any residual manure, after the completion of work.

After each “seasonal” manure spreading, thoroughly wash the spreader with clean water, dry it, and carry out maintenance work. It is recommended to use pressure washers for cleaning. When cleaning, exercise particular caution.

Cleaning guidelines:

- Do not hold the water jet closer than 40 cm from the surface to be cleaned. Washing surfaces with a strong jet of water from a short distance can damage lacquered surfaces,
- The water temperature must not exceed 50°C,
- Do not point the water jet directly at the following: electrical components, hydraulic and pneumatic components (cylinders, valves, connections), warning and information stickers, rating plate, lubricating points, etc.
- If it is necessary to use cleaning agents, carry out a trial washing of the surface on an inconspicuous place,
- Use petroleum ether or a degreasing agent to clean greasy parts, and then clean them with clean water,
- Do not use organic solvents or substances of unknown origin,
- Use suitable cleaning products to clean plastic or rubber surfaces,
- Wash the spreader at locations designated for such purposes, according to the environmental protection regulations,
- Clean and dry the spreader at a temperature above 0°C.



**DANGER**

**DANGER!**

Clean with the drive off, the PTO shaft disconnected and the tractor engine stopped. Remove the key from the ignition. Secure the tractor against unauthorized access.

Entering the spreader body is only permitted when the machine is stationary.



**CAUTION**

**CAUTION!**

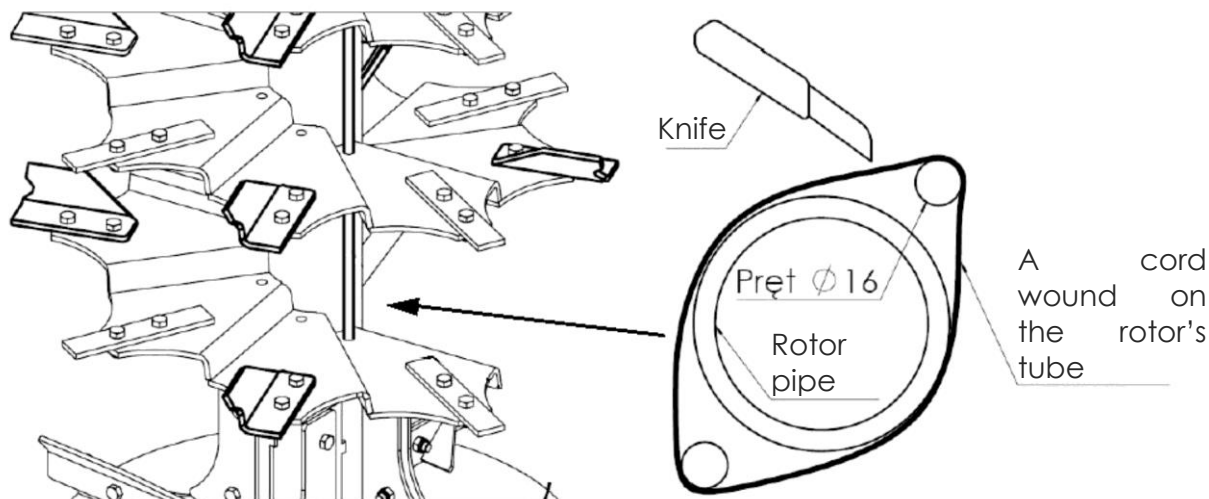
Wash with appropriate safety clothing on and use personal protective equipment.

Refer to the instructions for use, regarding cleaning products and the pressure washer.

### 5.8.1 Cleaning the Adapter

Keep the spreader clean, especially its adapter. Before cleaning the spreader, secure the tractor against unauthorised starting, disconnect the PTO shaft and the tractor's hydraulic system lines. Cleaning of the adapter should be carried out with a pressure washer providing a strong jet of water.

Remove any wound cords, nets, etc., with a blade at the location intended for this purpose (see the figure below).



**Figure 40** Cleaning of wound cords, nets

After the thorough cleaning and drying of the spreader, carry out proper maintenance work, replace missing paint coating, and lubricate the machine. After lubricating using the appropriate lubricating points, activate all mechanisms of the spreader to distribute the grease.

Apply a small amount of oil or anti-corrosive products in the locations where the lacquered surface has rubbed off naturally as a result of friction of moving material or friction between the parts rubbing against one another.

Store the spreader in a roofed area, adequately protected against unauthorised access. If stored outdoors, the spreader will be exposed to corrosive agents and UV radiation, which cause ageing of the lacquer coating.

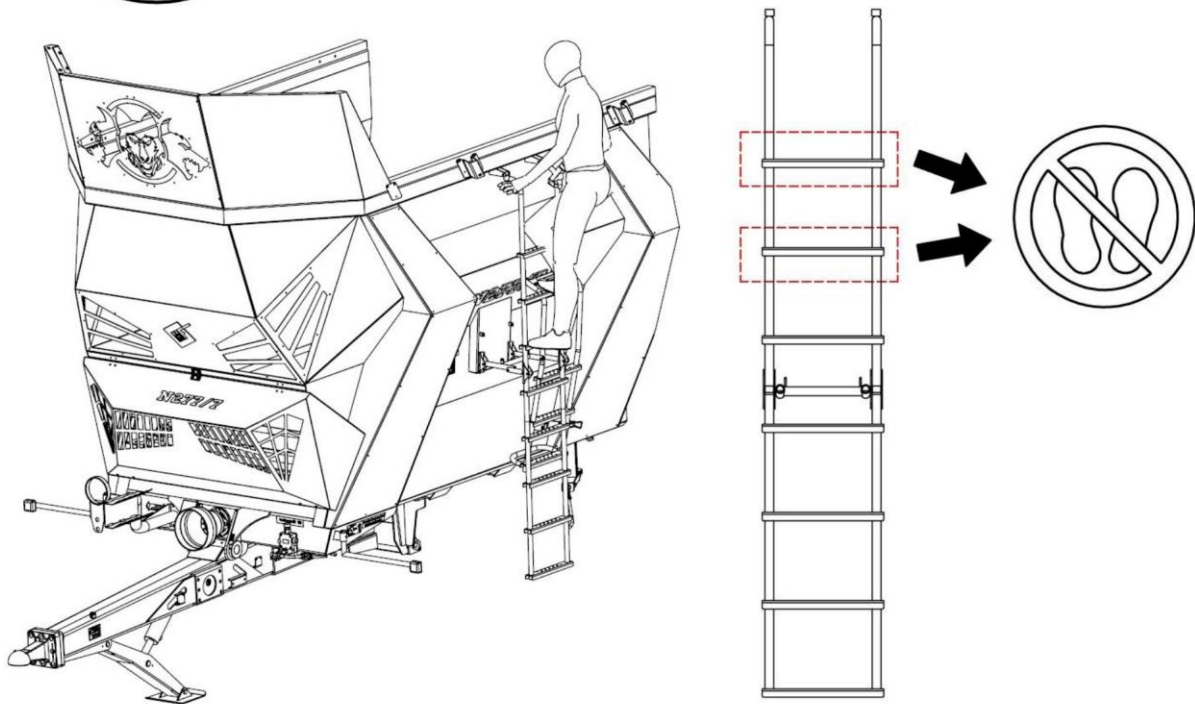
### 5.8.2 Cleaning the load body

The following figures (Fig. 41 and Fig. 42) show the use of the spreader ladders during inspection and cleaning of the load body.



**IT IS FORBIDDEN TO STAND ON THE INDICATED RUNGS WHEN INSPECTING THE INSIDE OF A LOAD BODY**

**WITHOUT SIDE EXTENSIONS FITTED**

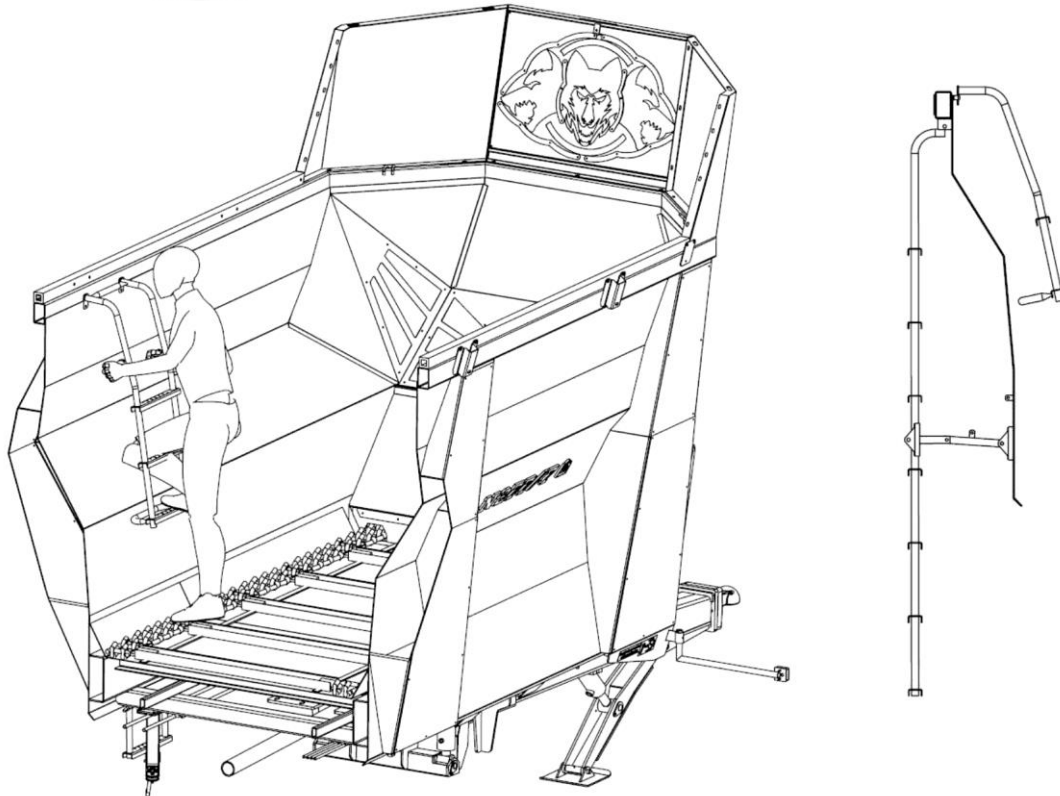


**Figure 41** Spreader load body inspection



**THE USE OF AN INTERNAL LADDER IS PERMITTED ONLY WHEN  
CLEANING THE INSIDE OF THE LOAD BODY**

**WITHOUT SIDE EXTENSIONS FITTED**



**Figure 42** Cleaning and maintenance of the spreader load body



**CAUTION**

**CAUTION!**

When cleaning the load compartment, all safety precautions must be observed in addition to switching off the engine, removing the key and disconnecting the PTO shaft

## 5.9 Tightening torques of screw connections

The optimum tightening torques for bolts with metric threads are shown in Table 17.

**Table 17** Tightening torques for screws with metric threads

Bolt		Tightening torques for bolts with metric threads [Nm]					
Diameter D [mm]	Pitch of thread [mm]	Screw strength classes					Wheel nuts, wheel screws
		4.8	5.8	8.8	10.9	12.9	
3	0.50	0.9	1.1	1.8	2.6	3.0	
4	0.70	1.6	2.0	3.1	4.5	5.3	
5	0.80	3.2	4.0	6.1	8.9	10.4	
6	1.00	5.5	6.8	10.4	15.3	17.9	
7	1.00	9.3	11.5	17.2	25	30	
8	1.25	13.6	16.8	25	37	44	
8	1.00	14.5	18	27	40	47	
10	1.50	26.6	33	50	73	86	45
10	1.25	28	35	53	78	91	
12	1.75	46	56	86	127	148	
12	1.50						80
12	1.25	50	62	95	139	163	
14	2.00	73	90	137	201	235	
14	1.50	79	96	150	220	257	140
16	2.00	113	141	214	314	369	
16	1.50	121	150	229	336	393	220
18	2.50	157	194	306	435	509	
18	1.50	178	220	345	491	575	300
20	2.50	222	275	432	615	719	
20	1.50	248	307	482	687	804	400
22	2.50	305	376	502	843	987	
22	2.00						450
22	1.50	337	416	654	932	1090	500
24	3.00	383	474	744	1080	1240	
24	2.00	420	519	814	1160	1360	
24	1.50						550
27	3.00	568	703	100	1570	1840	
27	2.00	615	760	1200	1700	1990	
30	3.50	772	995	1500	2130	2500	
30	2.00	850	1060	1670	2370	2380	

## 5.10 Troubleshooting

**Table 18** Troubleshooting

<b>Defect</b>	<b>Cause</b>	<b>Method of rectification</b>
<b>Impacts on the conveyor during operation</b>	Incorrect adjustment of the conveyor chain tension. Excessive extension of conveyor chains.	Check and adjust the tensioning of the chains.
<b>Blocking the spreading adapter</b>	The feeding speed of the floor conveyor is too high.	Reverse the floor conveyor to unlock the adapter and reduce the feeding speed.
	The blocking objects entered the spreading assembly together with the manure	Remove the cause of stopping the augers in the beater unit
	Rotational speed of tractor's PTO not correct	Change the rotational speed of tractor's PTO
	The PTO shaft operates at low speed.	Maintain an adequate tractor engine speed
<b>Floor feeder does not distribute the loaded material towards the beater unit</b>	The knob on the flow controller is set to "0-1"	Increase the set value on the flow controller.
	Excessive load weight results in overloading the floor feeder	Unload part of the load
	Low pressure in the tractor hydraulic system	Check the pressure in the tractor hydraulic system The minimum required hydraulic pressure of the tractor, measured with hot oil: 14 MPa, (140 bar)
	The engine overload valve of the hydraulic floor conveyor dirty and non-functional	Change the overload valve for a new one. Check the condition of the filters in the tractor's hydraulic system – if necessary, change both the filters and oil.
	Interrupted oil supply to the hydraulic motor of the conveyor	Check the connection and air-tightness of the hydraulic system.
<b>Spread width too small</b>	Rotational speed of tractor's PTO not correctly selected	Change the rotational speed of tractor's PTO
	The PTO shaft operates at low speed.	Maintain the correct rotational speed of the tractor's engine.



## INDEX OF NAMES AND ABBREVIATIONS

**dB (A)** – decibel A, sound pressure unit;

**kg** – kilogram, weight unit;

**km** – kilometre, a commonly used multiple measure of the metre, the basic unit of length in the SI system;

**kPa** – kilopascal, pressure unit

**HP** – horse power, power unit;

**m** – metre, length unit

**mm** – millimetre – auxiliary length unit equal to 0.001 m

**kPa** – Megapascal, a pressure unit;

**N** – Newton, an SI unit of force;

**Nm** – Newton-metre, a unit for the moment of force in the SI system;

**Pictogram** – an information plate;

**t** – tonne, a mass unit;

**Rating plate** – a manufacturer's plate unambiguously identifying the machine

**V** – Volt, a voltage unit;

**UV** – Ultraviolet radiation; It is an invisible electromagnetic radiation with a negative impact on human health; UV radiation has a negative effect on rubber parts;

**PTO** – Power take-off shaft;

**Transport (pickup) hitch** – the hitching components of a farming tractor (see the tractor's manual).

## ALPHABETICAL INDEX

### PART I

#### A

Adapter cover 34

#### B

Brake system 36

#### C

Coupling 38

#### D

Decommissioning 17

Description of design 33

Drive unit 34

#### E

Electrical system 38

Equipment 13

#### H

Hydraulic lines 21

Hydraulic system 22

#### I

Identification of the spreader 9

Intended use 12

#### L

Lighting 15, 23

Lighting system 38

Load 30, 33

#### P

Pneumatic system 22

Principles of operation 33

PTO 23

#### R

Rating plate 9

Residual Risk 24

#### S

Safety 18

Service brake 37

Slide gate 36

Spreading adapter	35
Stickers	25
Suspension	30
<b>T</b>	
Technical data	30
The feeding mechanism	34
Transport	14
Tyres	31

## PART II

### A

Adjusting Fertiliser Doses	16
Adjustment of wheel bearing play	30, 34

### B

Bearings	29
----------	----

### C

Chain tensioning	21
Cleaning	33, 41.42
Commissioning	8
Coupling	9

### D

Defects	41
Draining	32

### E

Electrical system	39
-------------------	----

### F

Filter cleaning	31
-----------------	----

### G

Gearbox	6, 24
---------	-------

### H

Hydraulic system	22
------------------	----

### L

Loading the Trailer body	14
Lubrication	25-29
Lubrication points	25-30

### O

Operation	6
-----------	---

### P

Pneumatic system	30
Preparing the machine for operation	6

### S

Shaft length adjustment	7
Spreading	15, 18
Storage	41

### T

Tightening torques	43
Tyres	38











Metal-Fach Sp. z o.o. is constantly improving its products and adjusting its package to the needs of its customers, so it reserves the right to make changes to its product range without notice. Therefore, before making your purchase decision, please contact an authorised dealer or sales representative of Metal-Fach Sp. z o.o. Metal-Fach Sp. z o.o. will not accept any complaints regarding the data and pictures contained in the catalogue, as the presented range of products does not constitute an offer within the meaning of the provisions of the Civil Code.

The pictures do not necessarily show standard accessories.

Original spare parts are available from authorised dealers, both in Poland and abroad, and also at the Metal-Fach retail outlet.



#### TECHNICAL SERVICE

16-100 Sokółka, ul. Kresowa 62

Telephone: +48 85 711 07 80; Fax: +48 85 711 07 93

serwis@metalfach.com.pl

#### SALES

16-100 Sokółka, ul. Kresowa 62

Telephone: +48 85 711 07 78; Fax: +48 85 711 07 89

handel@metalfach.com.pl

#### SPARE PARTS WHOLESALE STORE

16-100 Sokółka, ul. Kresowa 62

Wholesale: tel: +48 85 711 07 81; Fax: +48 85 711 07 93

serwis@metalfach.com.pl

Retail

24/7 TELEPHONE +48 533 111 477 tel.: +48 85 711 07 90

YOU CAN FIND UPDATED INFORMATION ABOUT OUR PRODUCTS ON [WWW.METALFACH.COM.PL](http://WWW.METALFACH.COM.PL)