



METAL-FACH



SELF-LOADING BALE WRAPPER

Z237

PARTS CATALOGUE

REV. II

MARCH 2022



The information included in the catalogue is valid as of the date of its preparation. The manufacturer reserves its right to make design changes to machines, and due to this, some values or illustrations might not correspond to the actual state of the machine supplied to the user. The manufacturer reserves its right to make design changes without changing this catalogue.

Table of Contents

1. MAIN FRAME.....	4
2. DRAWBAR.....	7
3. PARKING SUPPORT.....	9
4. MOVABLE FRAME.....	11
5. ROTARY FRAME, PART 1.....	15
6. ROTARY FRAME, PART 2.....	17
7. ROTARY FRAME – GEAR.....	20
8. ROTARY FRAME GEARBOX COVER.....	22
9. ROTARY FRAME – THICK SHAFT I.....	24
10. ROTARY FRAME – THIN SHAFT II.....	26
11. LOADING ARM.....	28
12. FILM FEEDER.....	30
13. MECHANICAL FILM CUTTER.....	34
14. HYDRAULICS – WORKING TABLE LOCK.....	37
15. HYDRAULICS – LIFTING AND LOWERING THE LOADING ARM.....	39
16. HYDRAULICS – LIFTING AND LOWERING THE MOBILE FRAME.....	41
17. HYDRAULICS – CONTROL LEVERS.....	43
18. LIGHTS.....	46
19. HITCH PROTECTION (EU APPROVAL) AND CONTAINER.....	48
NOTES.....	50

1. MAIN FRAME

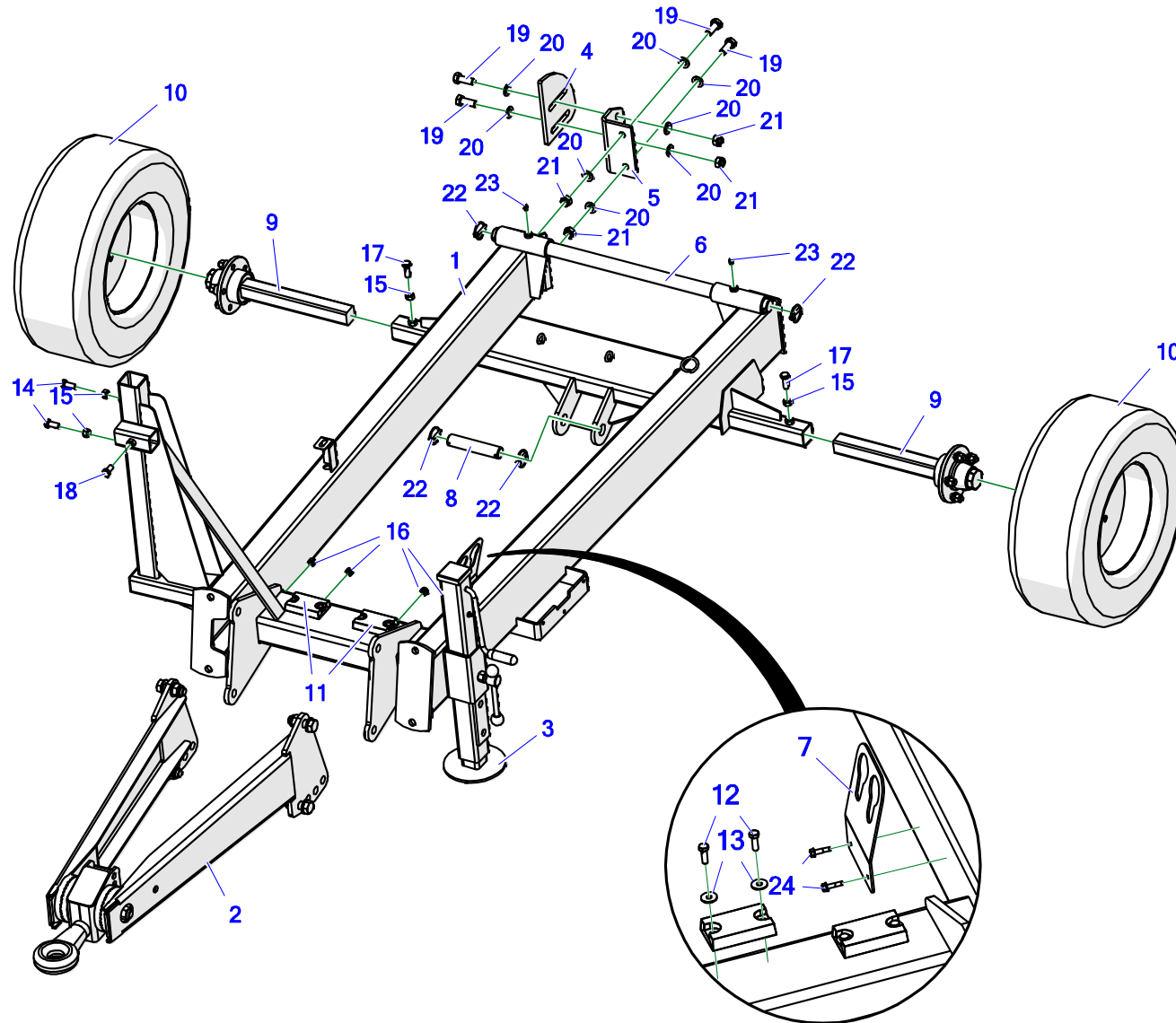
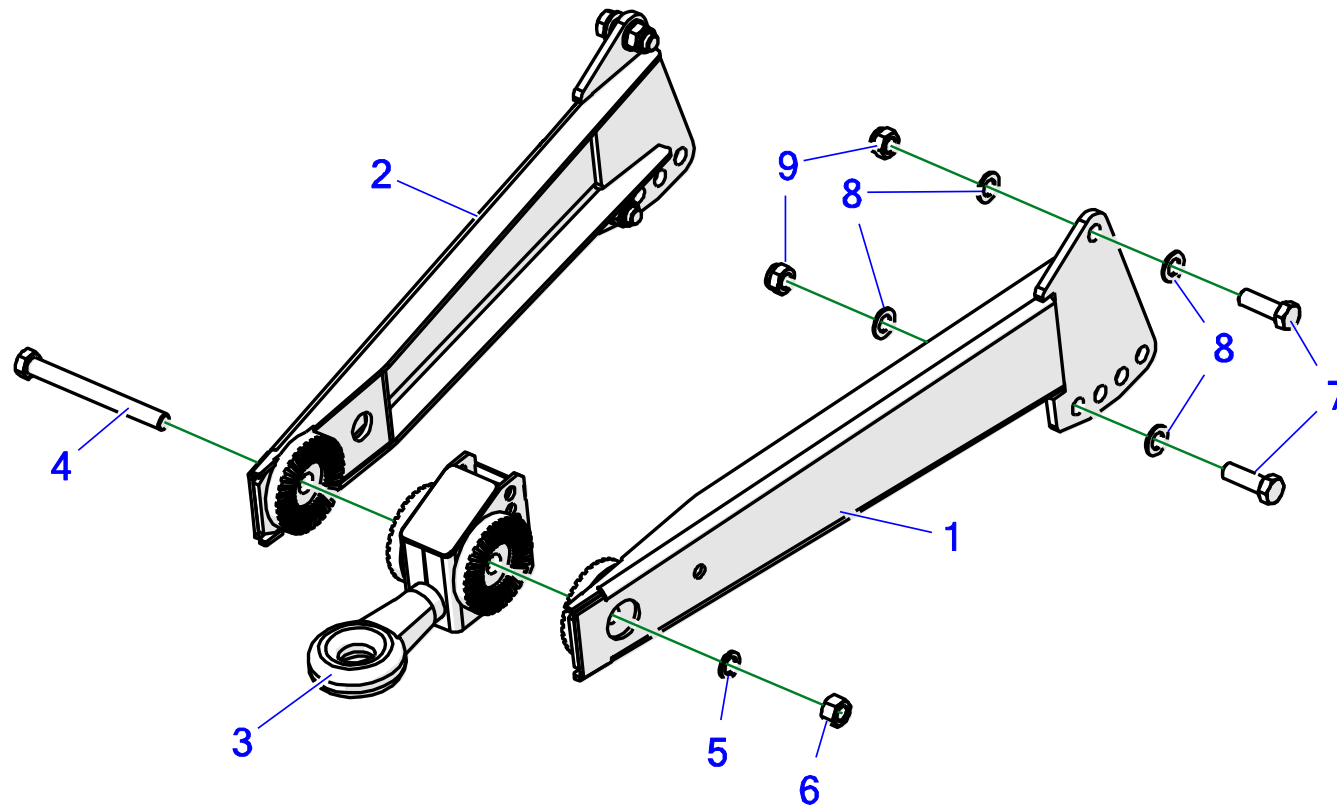

Table 1. Main frame

No.	No.	Part or assembly name	Volume
1	Z-237 01.01.00	Lower frame, welded	1
2	Z-577 01.03.00	Drawbar mount	1
3	Z577-10 01.02.00	Parking jack, welded	1
4	Z-237 00.00.31	Cam	1
5	Z-237 00.00.32	Bracket	1
6	Z-237 00.00.03	Main pin	1
7	Z598 03.00.01	Bracket for EURO plugs	1
8	Z-237 00.00.34	Pin I	1
9	25PQ040X0350 GA05	Cross shaft S40GAL500350A0001001 Z237	2
10	25K23X8,5-12ST-5510PR	wheel 23/8.5-12 10 PR	2
11	POD-TSZ-000007-1	Rubber bumper pad 65 x 100 with holes	2
12	23S8/25OC8.8	Bolt 8 x 25 galv., 8.8 82105 82105	4
13	23P8OC 82.030	Round washer 8 galv. coated 82030	4
14	23S12/30OC 8.8	Bolt 12 x 30 galv., 8.8 82105 82105	2
15	23N12OC	Nut M12 galv., 82144 5	4
16	POD-TSZ-000178	Round stopper, int. 18 mm black (Es-111529)	4
17	23S12/35OC 8.8	Bolt 12 x 35 galv., 8.8 82105 82105	2
18	23S12/25OC 8.8	Screw 12 x 25 galv., 8.8 82105 82105	1
19	23S16/40 8.8OC	Bolt 16 x 40 galv., 8.8 82105 82105	4

No.	No.	Part or assembly name	Volume
20	23P16OOC	Round washer 16 galv., 82005 82005	8
21	23NS16OC	Self-locking nut M16 galv., 82175 8 82175 8	4
22	23PR6	Cotter pin with a ring 6	4
23	23SM10/1	Lubricating nipple M10 x 1.0 straight	2
24	28W6,3X25 OC	Screw, self-drilling, 6.3 x 25 gal hex head	2

2. DRAWBAR



Z-577 01.03.00

Table 2. Drawbar

Drawbar mount - Z-577 01.03.00

No.	No.	Part or assembly name	Volume
1	Z-577 01.03.30	Left hitch arm, cpl.	1
2	Z-577 01.03.40	Right hitch arm, cpl.	1
3	Z-577 01.03.50	Hitch	1
4	POD-ELZ-000924	bolt 20 x 200 galv., 10.9 82101	1
5	23P20SP	Spring washer, 20.5 galv., 82008 82008	1
6	23N M20 CL.8 DIN934OC	Nut M20 galv., 8.8 DIN934 8 DIN934 8	1
7	23S20/60OC 8.8	Bolt 20 x 60 galv., 8.8 82101 82101	4
8	23P20OOC	Round washer 20 galv., 82005 82005	8
9	23NS20OC 82.175	Self-locking nut M20 galv., 82175 8 82175 8	4

3. PARKING SUPPORT

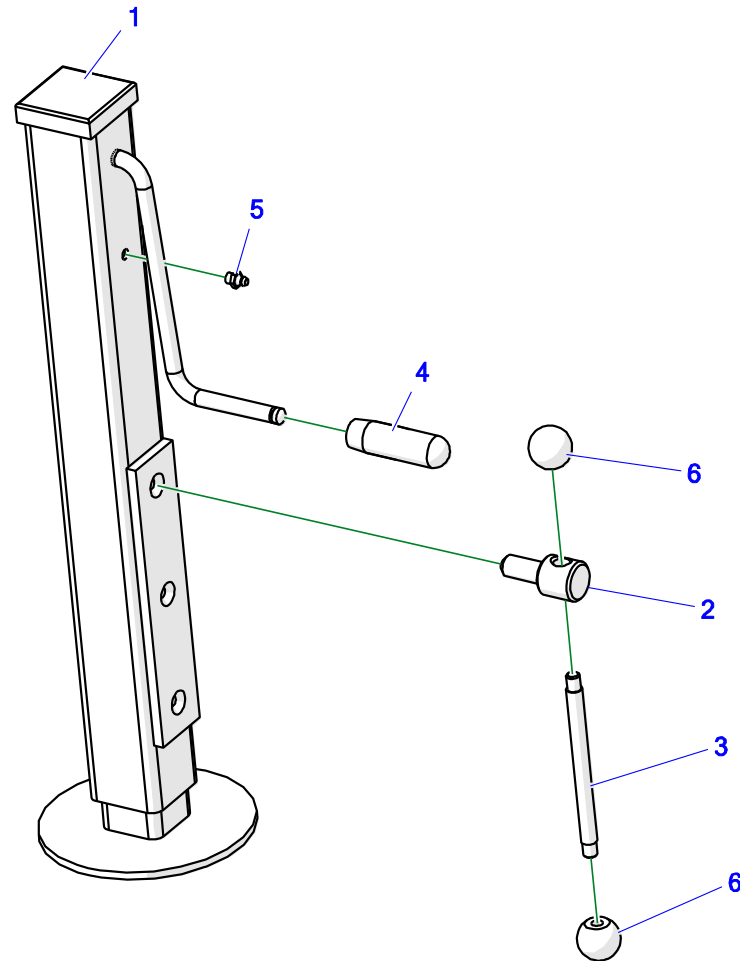
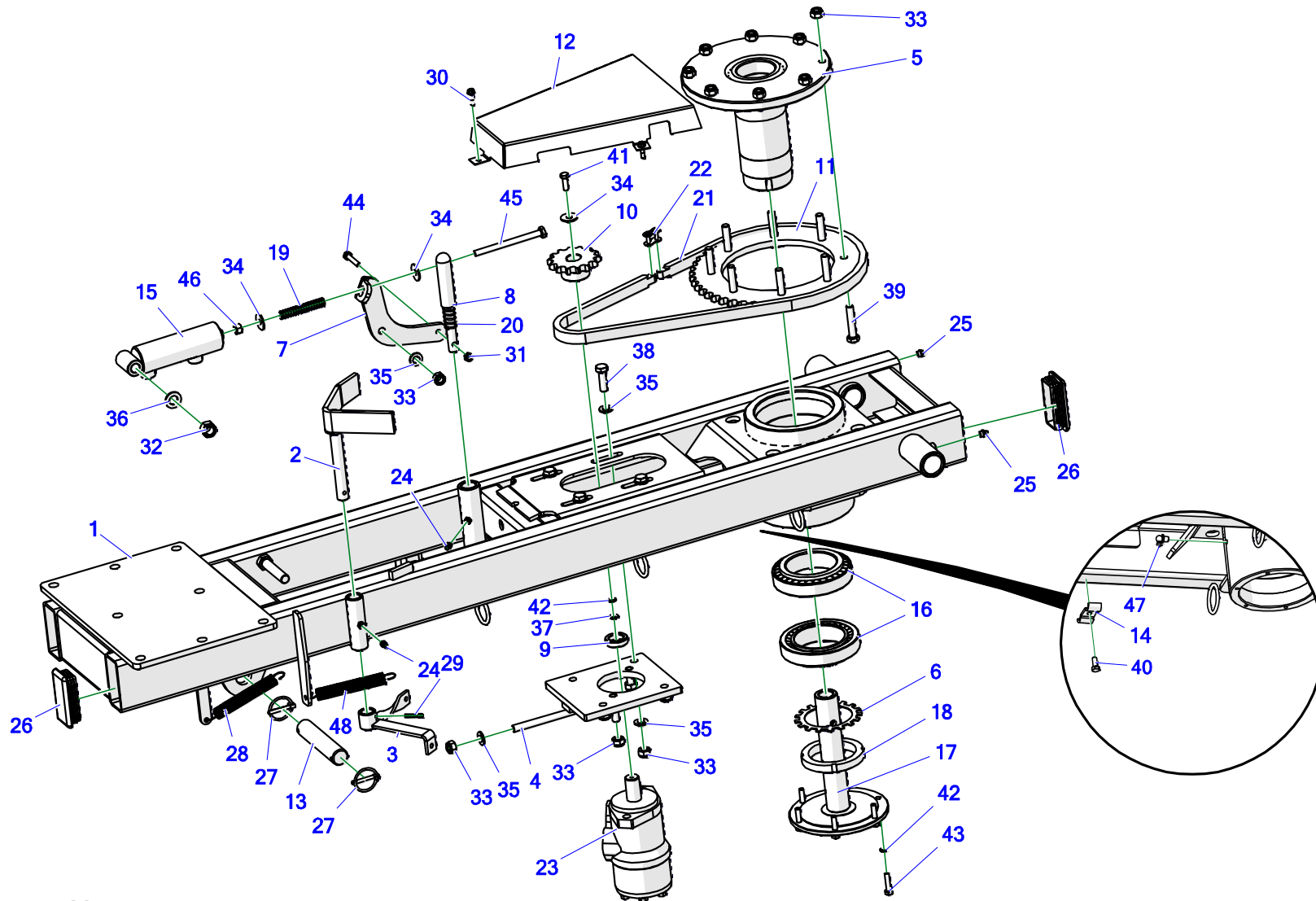

Table 3. Parking jack

No.	No.	Part or assembly name	Volume
1	Z577-10 01.02.00	self-loading parking jack	1
2	Z577-10 01.02.12	Hand wheel bolt	1
3	Z577-10 01,02.11	Hand wheel rod	1
4	25RP	Feeder handle	1
5	23SM8	Grease nipple, M8 x 1.0, straight	1
6	28B32 M10	Knob B32 M10 No. 462099	2

4. MOVABLE FRAME



Z-237 02.00.00M

Table 4. Movable frame

Movable frame mount - Z-237 02.00.00M

No.	No.	Part or assembly name	Volume
1	Z-237 02.01.00*	Movable frame	1
2	Z-237 00.04.00	Lever I	1
3	Z-237 00.05.00	Lever II	1
4	Z-237 00.10.00.1	Engine support	1
5	Z-237 00.15.00.1	Journal, complete	1
6	Z-237 00.16.00	Axle, complete	1
7	Z-237 00.00.06	Lever III	1
8	Z-237 00.00.07	Lock pin	1
9	Z-237 00.00.11	Engine spacer	1
10	Z-237 00.00.12	Chain wheel Z-14	1
11	Z-237 00.00.14.1	Chain wheel Z-50	1
12	Z-577 02.00.22.1	Chain transmission guard	1
13	Z-237 00.00.34	Pin I	1
14	Z-593 01.00.11	Hose clamp	1
15	24SCJ2F40/22/65	Actuator 40/22/65*L-180	1
16	25L32018	32018 bearing	2
17	25PL	Bearing washer MB17	1
18	25L17KM	KM17(N) bearing nut	1

No.	No.	Part or assembly name	Volume
19	23S22	Compression spring 2/15/85/18.5 galv., (maz-2046)	1
20	23SPS2/17/75	Compression spring 2.5/22/75/10 galv., (maz-2047)	1
21	25LO12B1 73OGN	Chain 12B1 73 links (1.45 m)	1
22	25LO12P	Chain link 12B1 R-1 3/4"	1
23	24S200	OMR 200 (BMR) hydraulic motor	1
24	23SM	Grease nipple M6 x 1.0 straight	2
25	23SM10/1	Lubricating nipple M10 x 1.0 straight	2
26	23WRP	Stopper, square int. 100 x 50 mm black (TL-199195)	2
27	23PR6	Cotter pin with a ring 6	2
28	23P2/20/200	Tension spring 1.5/20/160/79.5 galv., (maz-2048)	1
29	23K6/32	Resilient stud 6 x 32 DIN 1481	1
30	28W6,3X25 OC	Screw, self-drilling, 6.3 x 25 galv., hex head	3
31	23NS8OC	Self-locking nut M8 galv., 82175 8 82175 8	1
32	23NS16OC	Self-locking nut M16 galv., 82175 8 82175 8	1
33	23NS12OC	Self-locking nut M12 galv., 82175 8 82175 8	16
34	23P10 OC030	Round washer 10 galv., coated 82030 82030	3
35	23P12OC	Round washer 12 galv., 82005	10
36	23P16OOC	Round washer 16 galv., 82005 82005	1
37	23P8OOC	Round washer 8 galv., 82005 82005	1

No.	No.	Part or assembly name	Volume
38	23S12/40OC	Bolt 12 x 40 galv., 8.8 82101 82101	4
39	23S12/60OC 8.8	Bolt 12 x 60 galv., 8.8 82101 82101	8
40	23S8/20OC 8.8	Bolt 8 x 20 galv., 8.8 82105 82105	1
41	23S8/25OC8.8	Bolt 8 x 25 galv., 8.8 82105 82105	1
42	23P8SPOC	Spring washer 8.2 galv., 82008 82008	7
43	23S8/35OC 8.8	Bolt 8 x 35 galv., 8.8 82105 82105	6
44	23S8/45OC 8.8	Bolt 8 x 45 galv., 8.8 82105 82105	1
45	23S10/130OC	Bolt 10 x 130 galv., 8.8 82101 82101	1
46	23N10OC	Nut M10 galv., 82144 5 82144 5	1
47	23SM10KAT90	lubricating nipple M10 x 1.0 90 angle	1
48	23S1.5/20/160	Tension spring 1.5/20/160/79.5 galv., (maz-2048)	1

*Z-237 02.00.00 mobile frame index up to and including 2022

**The moving frame equipment also includes: Wire rope – 23LS4 and rope clamp – 23ZL

5. ROTARY FRAME, PART 1

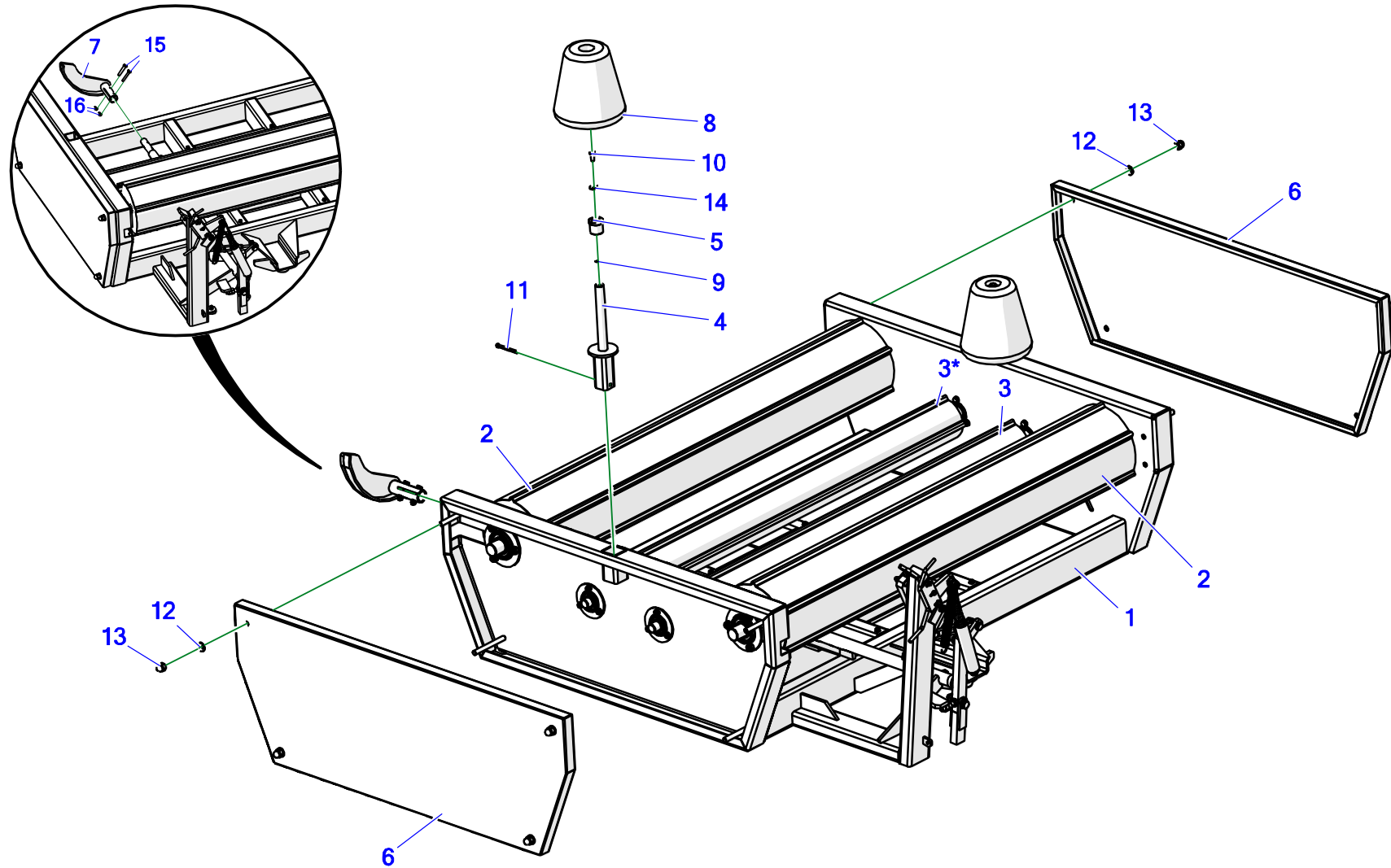

Table 5. Rotary frame, part 1

No.	No.	Part or assembly name	Volume
1	Z-237 33.01.00.1	Welded frame	1
2	Z-237 33.20.00	Thick shaft I	2
3	Z-237 33.19.00	Thin shaft II, left	1
3*	Z-237 33.19.00	Thin shaft II, right	1
4	Z-237 05.01.00	Side wheel bracket	2
5	Z-237 05.00.04	Bevel wheel hub	2
6	Z-237 33.00.30	Side guard	2
7	Z-237 33.07.00	Lever guide	1
8	25KS	Bale wrapper cone wheel	2
9	23P8SPOC	Spring washer 8.2 galv., 82008 82008	2
10	23S8/20OC 8.8	Bolt 8 x 20 galv., 8.8 82105 82105	2
11	23Z6/63	Cotter pin 6.3 x 63 galv.,	2
12	23P12OC	Round washer 12 galv., 82005	8
13	23N12KOL	Acorn nut M12 galv., 82181 8 82181 8	8
14	23P8OC 82.030	Round washer 8 galv., coated 82030	2
15	23S8/45OC 8.8	Bolt 8 x 45 galv., 8.8 82105 82105	2
16	23NS8OC	Self-locking nut M8 galv., 82175 8 82175 8	2

6. ROTARY FRAME, PART 2

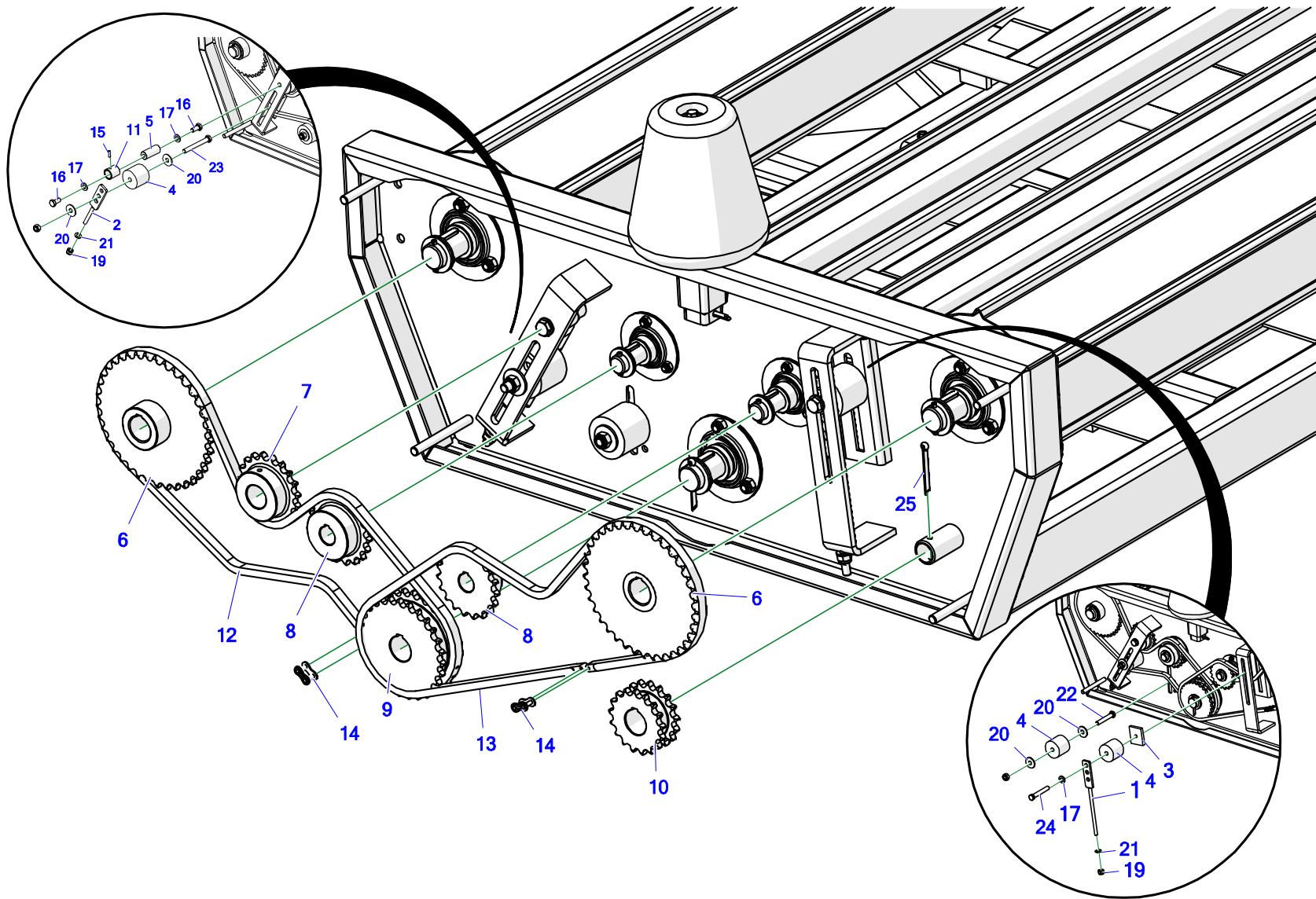

Table 6. Rotary frame, part 2

No.	No.	Part or assembly name	Volume
1	Z-237 33.64.00	Tensioner II	1
2	Z-237 33.66.00	Tensioner I	1
3	Z-237 33.00.32	Threaded block M12	1
4	Z-237 33.00.27	Chain tensioner I	3
5	Z-237 33.00.10	Wheel axle Z-19	1
6	Z-237 33.17.00.1	Chain wheel Z-37	2
7	Z-237 33.00.48	Chain wheel Z-19	1
8	Z-237 33.00.16.1	Chain wheel Z-19	2
9	Z-237 33.00.15.1	Chain wheel Z-27	1
10	Z-237 33.00.12	Chain wheel Z-17	1
11	25T25/32.6/35	Self-lubricating sleeve 25H7/32.6x35	1
12	25LO10B1 99OGN.	Chain 10B1 99 links	1
13	25LO10B1 93OGN	Chain 10B1 93 links	1
14	25LO10P	Chain link 10B1 R-1 5/8"	2
15	POD-ELZ-000346	Resilient stud 6 x 20 DIN 1481	1
16	23S12/25OC 8.8	Screw 12 x 25 galv., 8.8 82105 82105	2
17	23P12OC	Round washer 12 galv., 82005	3
18	23NS12OC	Self-locking nut M12 galv., 82175 8 82175 8	2
19	23NS10OC	Self-locking nut M10 galv., 82175 8 82175 8	2

No.	No.	Part or assembly name	Volume
20	23P12OOC	Washer, round 12 galv., coat. 82030	4
21	23P10 82.005	Round washer 10 galv., 82005 82005	2
22	POD-ELZ-000081	Bolt 12 x 75 galv., 8.8 82101	1
23	23S12/100OC 8.8	Bolt 12 x 100 galv., 8.8 82101 82101	1
24	23S12/80OC 8.8	Bolt 12 x 80 galv., 8.8 82101 82101	1
25	23Z6/63	Cotter pin 6.3 x 63 galv.,	1

7. ROTARY FRAME – GEAR

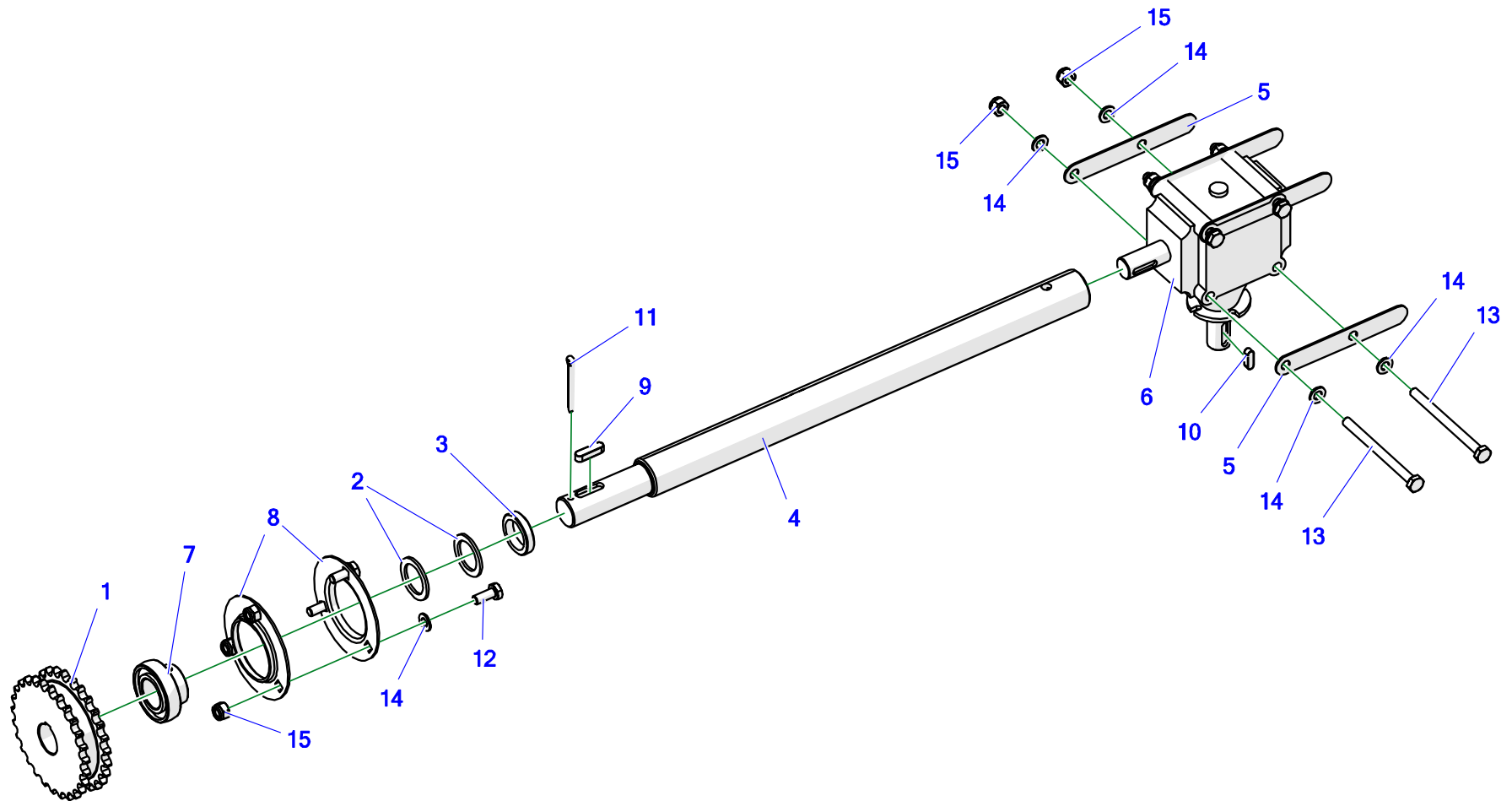

Table 7. Rotary frame – gear

No.	No.	Part or assembly name	Volume
1	Z-237 33.00.15.1	Chain wheel Z-27	1
2	Z-237 33.00.14	Washer I	2
3	Z-237 33.00.13	Distance sleeve II	1
4	Z-237 33.00.11.1	Wheel drive shaft Z-17	1
5	Z-577 03.00.01	Gearbox spacer plate	4
6	25PPS	Self-loading gearbox 005-03.OGGRO(MB30.01)	1
7	25L207	Bearing FD207	1
8	25OP207	Metal housing P-207	2
9	23WP10/8/36	Groove 10 x 8 x 36	1
10	23WP8/7/25	Key groove 8 x 7 x 25 DIN6885A DIN6885A	1
11	23Z6/63	Cotter pin 6.3 x 63 galv.,	1
12	23S10/25OC 8.8	Bolt 10 x 25 galv., 8.8 82105 82105	3
13	23S10/130OC	Bolt 10x130 galv., 8.8 82101 82101	4
14	23P10 82.005	Round washer 10 galv., 82005 82005	11
15	23NS10OC	Self-locking nut M10 galv., 82175 8 82175 8	7

8. ROTARY FRAME GEARBOX COVER

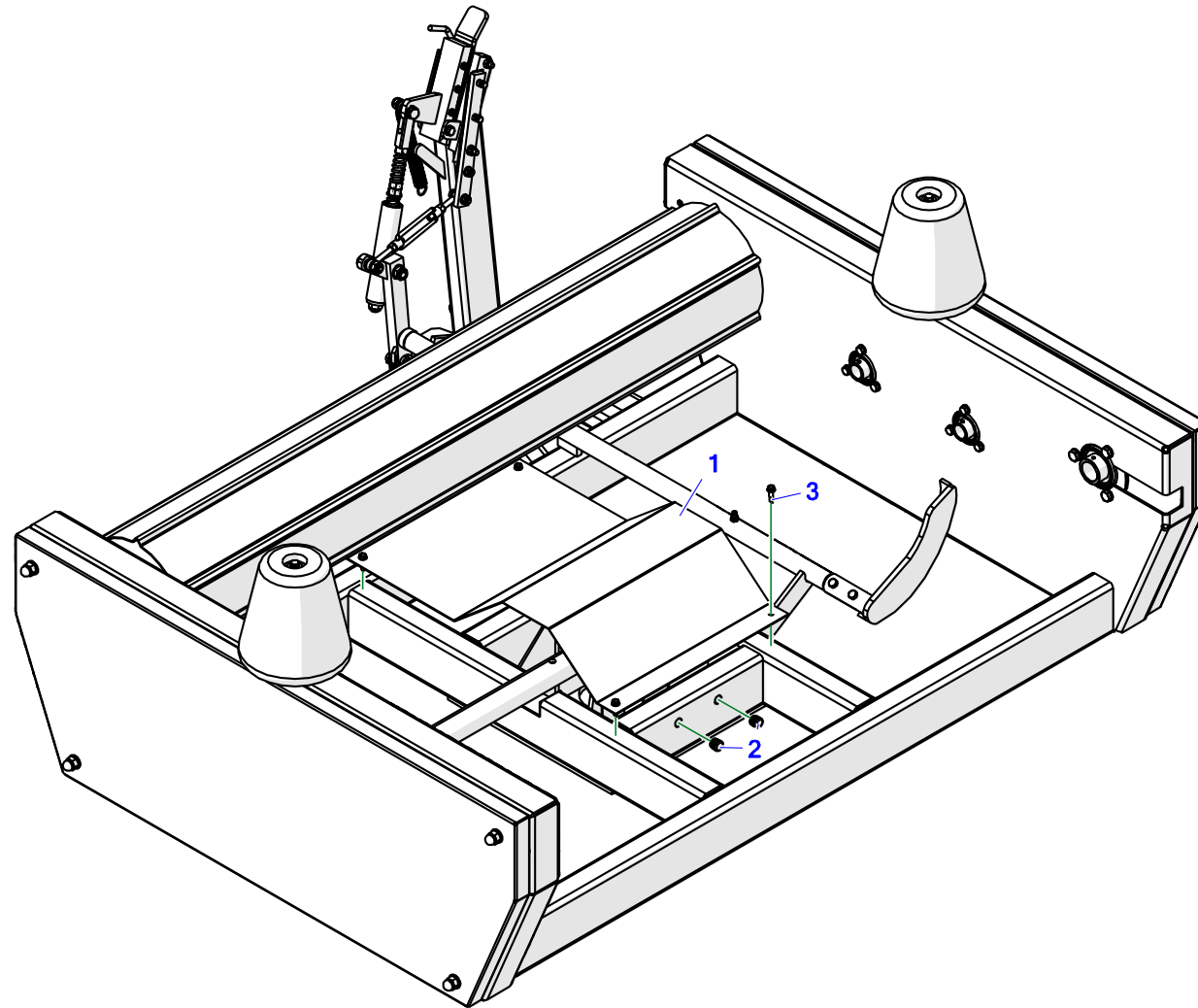

Table 8. Rotary frame gearbox cover

No.	No.	Part or assembly name	Volume
1	Z-237 33.00.31	Gear guard	1
2	POD-TSZ-000178	Round stopper, int. 18 mm black (Es-111529)	2
3	28W6,3X25 OC	Screw, self-drilling, 6.3 x 25 gal hex head	4

9. ROTARY FRAME – THICK SHAFT I

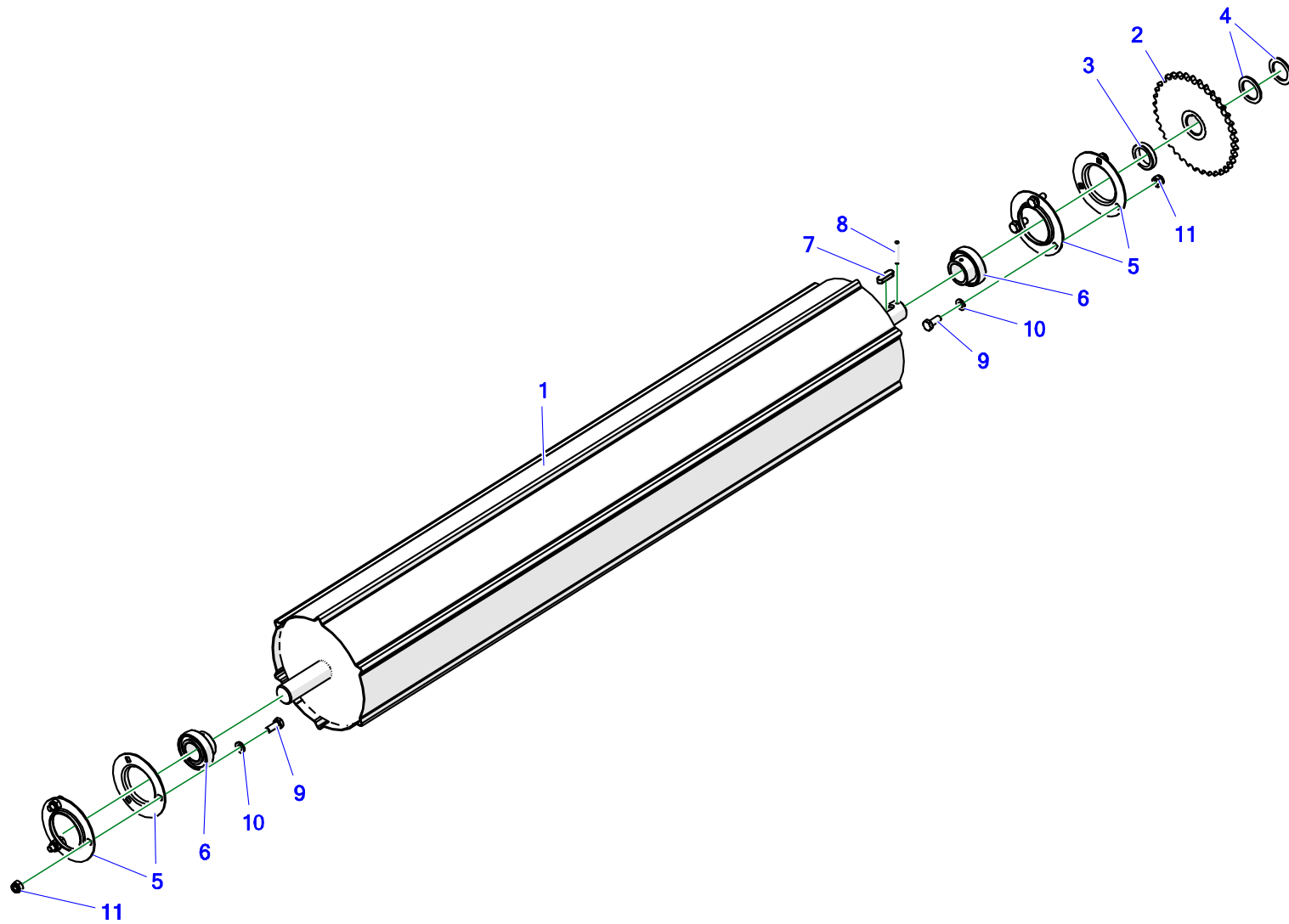

Table 9. Rotary frame – thick shaft i

No.	No.	Part or assembly name	Volume
1.	Z-237 33.20.00	Thick shaft I	1
2.	Z-237 33.17.00.1	Chain wheel Z-37	1
3.	Z-237 33.00.13	Distance sleeve II	1
4.	Z-237 33.00.14	Washer I	2
5.	25OP207	Metal housing P-207	4
6.	25L207	Bearing FD207	2
7.	23WP10/8/36	Groove 10 x 8 x 36	1
8.	23K6/45	Spring pin 6 x 45 DIN 1481	1
9.	23S10/25OC 8.8	Bolt 10 x 25 galv., 8.8 82105 82105	6
10.	23P10 82005	Round washer 10 galv., 82005 82005	6
11.	23NS10OC	Self-locking nut M10 galv., 82175 8 82175 8	6

10. ROTARY FRAME – THIN SHAFT II

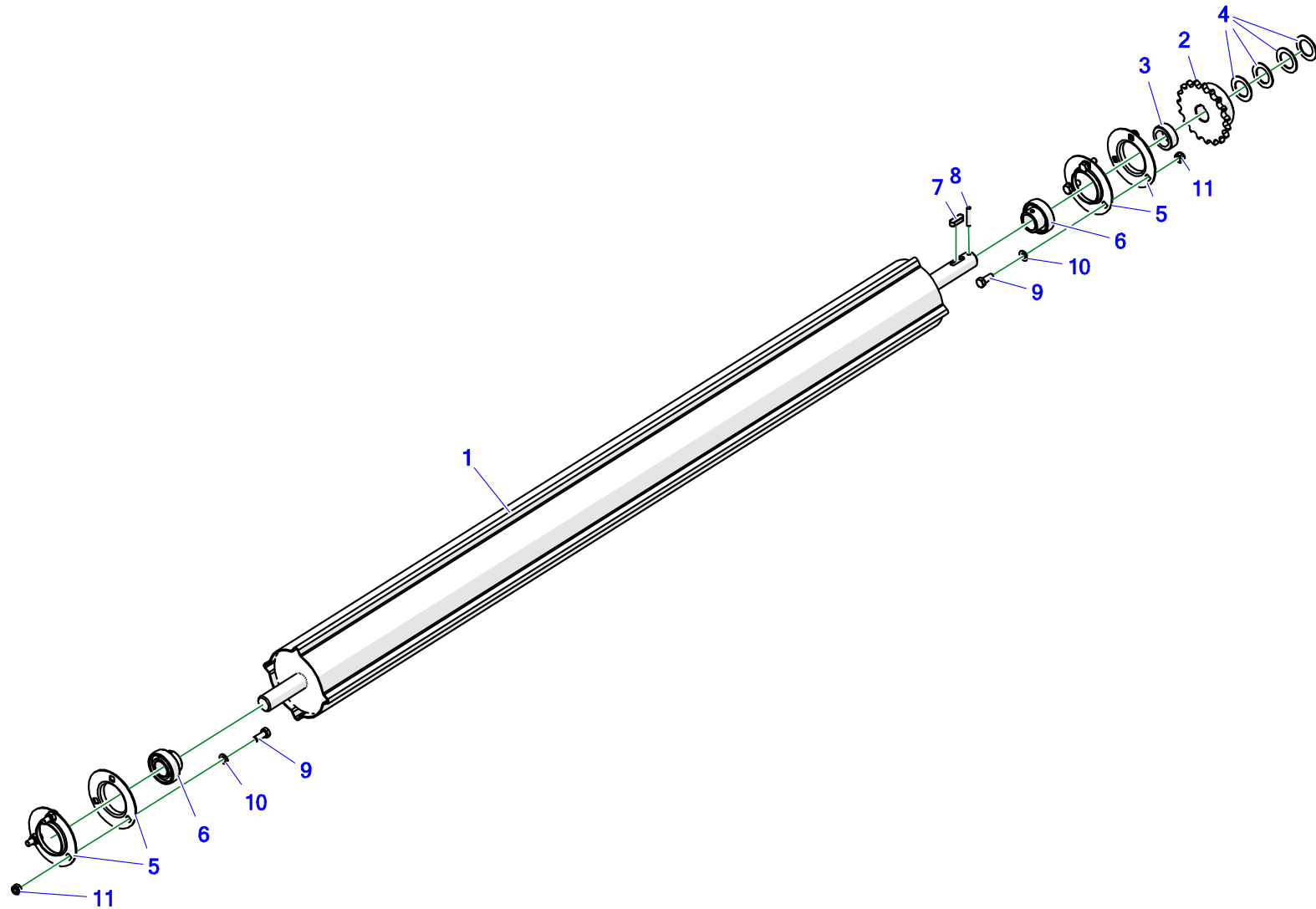

Table 10. Rotary frame – thin shaft II

No.	No.	Part or assembly name	Volume
1.	Z-237 33.19.00	Thin shaft II	1
2.	Z-237 33.00.16.1	Chain wheel Z-19	1
3.	Z-237 33.00.22*	Distance sleeve III	1
3.	Z-237 33.00.24**	Distance sleeve IV	1
4.	Z-237 33.00.25***	Washer V	4 / 3
5.	25OP205	Metal housing P-205	4
6.	25L205	Bearing FD205	2
7.	23WP8/7/25	Key groove 8 x 7 x 25 DIN6885A DIN6885A	1
8.	23K6/32	Resilient stud 6 x 32 DIN 1481	1
9.	23S8/20OC 8.8	Bolt 8 x 20 galv., 8.8 82105 82105	6
10.	23P8OOC	Round washer 8 galv., 82005 82005	6
11.	23NS8OC	Self-locking nut M8 galv., 82175 8 82175 8	6

* The spacer sleeve with the index Z-237 33.00.22 is used for the left-hand thin shaft II – see table 5 item 3 and 3*

** The spacer sleeve with the index Z-237 33.00.24 is used for the right-hand thin shaft II – see table 5 item 3 and 3*

*** Washer V with the index Z-237 33.00.25 is used in quantity of 3 pieces in the left-hand thin shaft II and in quantity of 4 pieces in the right-hand thin shaft II – see table 5 point 3 and 3*

11. LOADING ARM

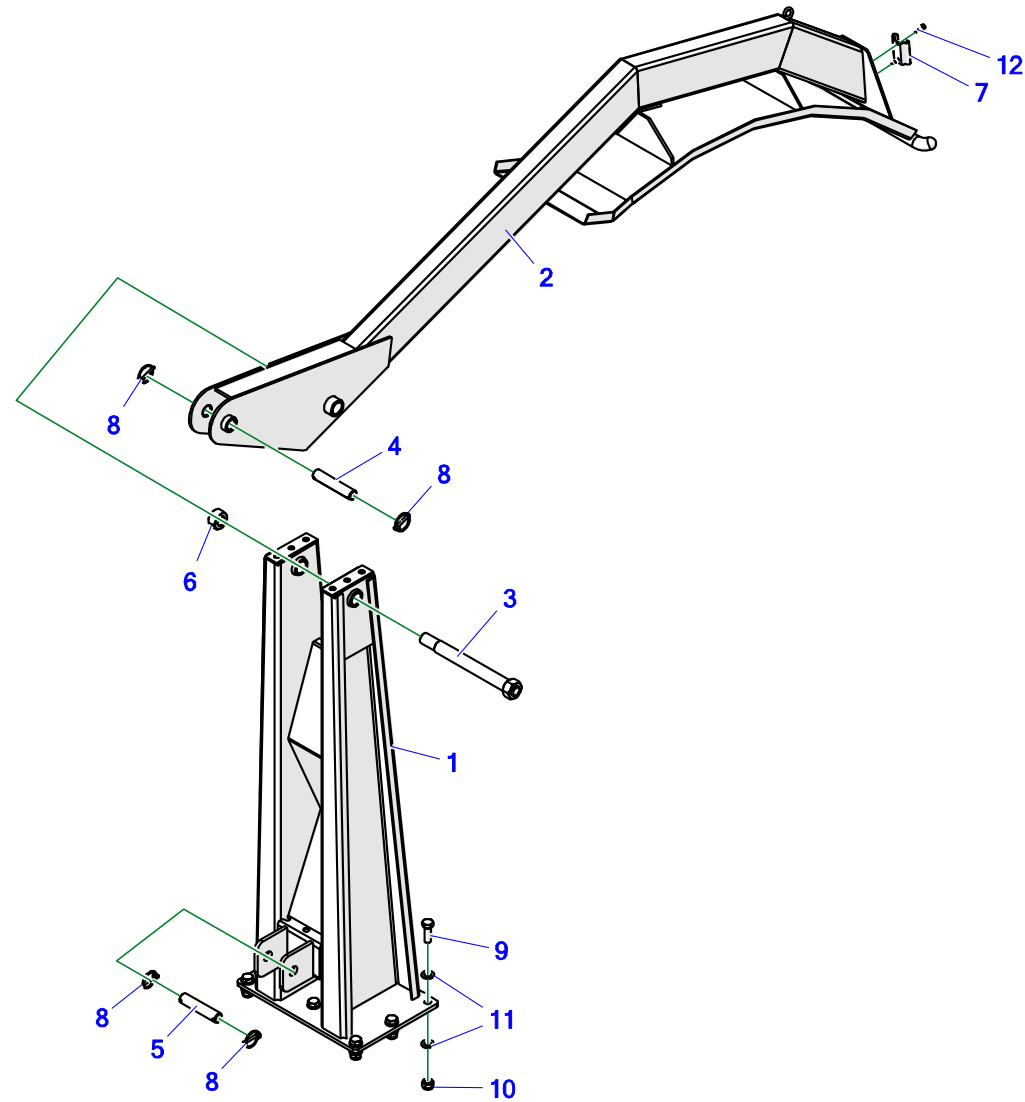

Z-237 04.00.00M

Table 11. Loading arm

Loading assembly mount - Z-237 04.00.00M

No.	No.	Part or assembly name	Volume
1.	Z-237 00.19.00	Boom, complete	1
2.	Z-237 00.20.00	Bale clamp cpl.	1
3.	Z-237 00.87.00	Special bolt M27	1
4.	Z-237 00.00.36	Pin III	1
5.	Z-237 00.00.35	Pin II	1
6.	23N27OC	Nut M27 part 82144 5 82144 5	1
7.	27UM	SMV emblem mount	1
8.	23PR6	Cotter pin with a ring 6	4
9.	23S16/45OC	Screw 16 x 45 galv., 8.8 82105 82105	8
10.	23NS16OC	Self-locking nut M16 galv., 82175 8 82175 8	8
11.	23P16OOC	Round washer 16 galv., 82005 82005	16
12.	28W6,3X25 OC	Screw, self-drilling, 6.3 x 25 galv., hex head	2

12. FILM FEEDER

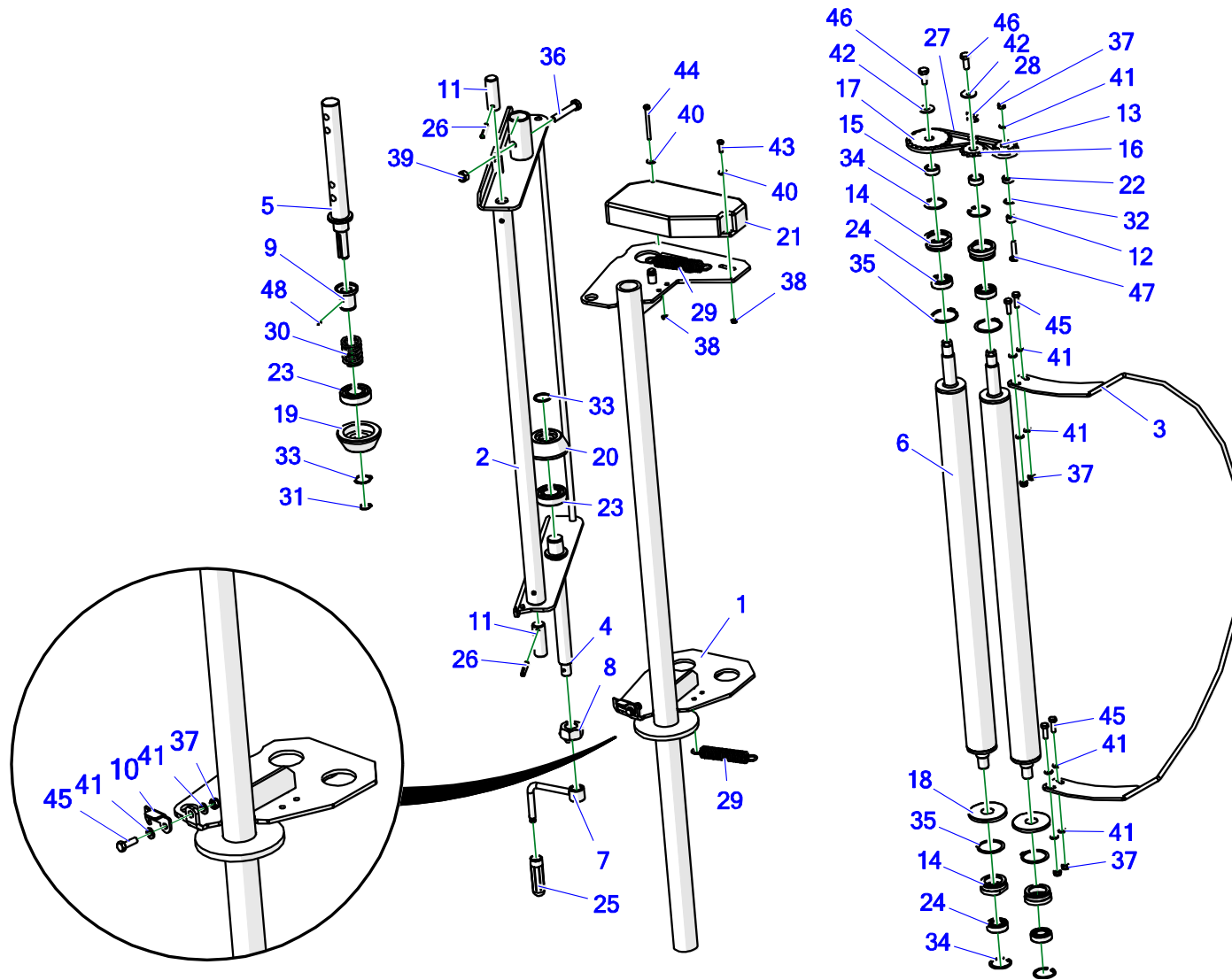

Z-237 17.00.00

Table 12. Film feeder

Film feeder, mount - Z-237 17.00.00

No.	No.	Part or assembly name	Volume
1.	Z-237 17.01.00	Mounting bracket, welded	1
2.	Z-237 17.02.00	Film bracket welded	1
3.	Z-237 17.03.00	Welded bar	1
4.	Z593-1E 07.06.00.1	Lower bracket, cpl.	1
5.	Z593-1E 07.07.00.1	Upper bracket, cpl.	1
6.	Z-577 17.08.00	Pressure roller	2
7.	Z-560 02.37.00.1	Handle set	1
8.	Z-560 02.38.00	Backnut M27	1
9.	Z-560 02.00.311.2	Sleeve	1
10.	Z-237 18.00.04	Lock	1
11.	Z-560 02.00.07	Foil bracket shaft	2
12.	Z-560 02.00.08	Distance sleeve II	1
13.	Z-560 02.00.09	Chain wheel Z-11	1
14.	Z-560 02.00.25.1	Shaft mounting	4
15.	Z-560 02.00.26	Distance sleeve III	2
16.	Z-560 02.00.30	Chain wheel Z-12	1
17.	Z-560 02.00.32	Chain wheel Z-21	1
18.	Z-560 02.00.36	Bearing guard	2

No.	No.	Part or assembly name	Volume
19.	Z-560 02.00.41.1	Film mount, upper	1
20.	Z-593 17.00.02	Pressure cone II	1
21.	POD-TSZ-000032	Tensioner guard ABS Z237	1
22.	25L608 2RS	Bearing 608 2RS	1
23.	25L6206	Bearing 6206 2RS	2
24.	25L6004	Bearing 6004 2RS	4
25.	25RP	Feeder handle	1
26.	23K8/50	Spring pin 8 x 50 DIN 1481	2
27.	25LO08B1 43OGN	Chain 08B1 43 links	1
28.	25LO08P	Chain link 08B1 R-1 1/2"	1
29.	23SPN3/23/135 MAZ1771/1	Tension spring 3/23/136/34 galv., (maz-1771/B-1)	2
30.	23S4/32/50	Compression spring 4/40/50/7, galv., (maz-2401)	1
31.	23SZ20	Circlip, Z20	1
32.	23SW22	Circlip, W22	1
33.	23SZ30	Circlip, Z30	2
34.	23SW42	Circlip, W42	4
35.	23SZ50	Circlip, Z50	4
36.	23S12/60OC 8.8	Bolt 12 x 60 galv., 8.8 821001 82101	1
37.	23NS8OC	Self-locking nut M8 galv., 82175 8 82175 8	6

No.	No.	Part or assembly name	Volume
38.	23NS6OC	Self-locking nut M6 galv., 82175 8 82175 8	2
39.	23NS12OC	Self-locking nut M12 galv., 82175 8 82175 8	1
40.	23P6OC030	Round washer 6 galv. coated 82030	2
41.	23P8OOC	Round washer 8 galv., 82005 82005	11
42.	23P10 OC030	Round washer 10 galv., coated 82030 82030	2
43.	23S6/20	Bolt 6 x 20 galv., 8.8 82105 82105 8.8	1
44.	23S6/70 105	Bolt 6 x 70 galv., 8.8 82101 82101 8.8	1
45.	23S8/25OC8.8	Bolt 8 x 25 galv., 8.8 82105 82105	5
46.	23S10/25OC 8.8	Bolt 10 x 25 galv., 8.8 82105 82105	2
47.	23S8/40P	Carriage bolt 8 x 40 galv., 8.8 82406 82406	1
48.	POD-ELZ-000659	Allen set screw 6 x 8 DIN913 galv.	1

13. MECHANICAL FILM CUTTER

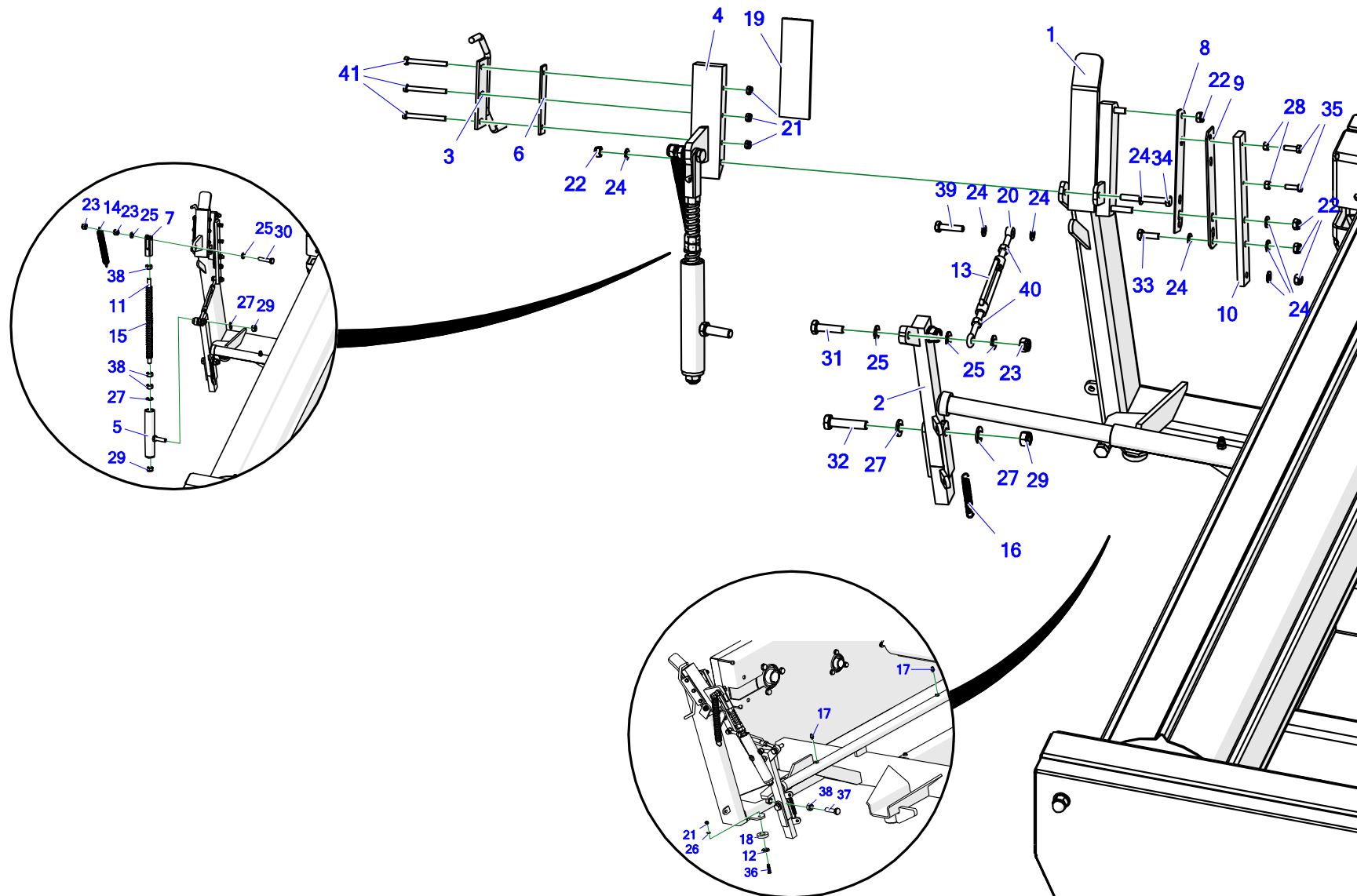

Table 13. Mechanical film cutter

No.	No.	Part or assembly name	Volume
1.	Z-237 33.01.00.1	Welded frame	1
2.	Z-237 33.65.00.1	Brace cpl.	1
3.	Z-237 33.04.01.1	Welded lever	1
4.	Z-237 33.04.20	Welded clamp	1
5.	Z-237 33.03.100	Tube cpl.	1
6.	Z-577 03.17.05	Spacer plate	1
7.	Z-237 33.03.04	Fork end	1
8.	Z-577 03.17.52.2	Movable cutter	1
9.	Z-577 03.17.52.2	Movable cutter	1
10.	Z-577 03.17.51.1	Movable cutter holder	1
11.	POD-ELZ-000797	Threaded rod 12 x 310 galv. 5.8	1
12.	Z-552 00.00.02	Magnet washer	1
13.	23SNO8/110OC	Screw tension hole M8 x 110 galv., (eye+eye dia. 10) DIN1480	1
14.	23SP2/20/200	Tension spring 2/20/200/69.5 galv., (maz-2050)	1
15.	23SS3/22/230	Compression spring 3.5/22/260/32 galv., (maz-2049)	1
16.	23s1,5/10/80	tension spring 1.5/10/80/36 galv., (maz-2446)	1
17.	23SM	Grease nipple M6 x 1.0 straight	2
18.	25MG	Ferrite ring magnet 36 x 18 x 8/F30	1
19.	POD-TSZ-000037 (45x145)	Corrugated rubber plate #4-(CSG-4/1200 narrow stomil corrugation) (45x145)	1
20.	POD-ELZ-000547	eye bolt 8 x 60, DIN444 galv.	1
21.	23NS6OC	Self-locking nut M6 galv., 82175 8 82175 8	4

No.	No.	Part or assembly name	Volume
22.	23NS8OC	Self-locking nut M8 galv., 82175 8 82175 8	5
23.	23NS10OC	Self-locking nut M10 galv., 82175 8 82175 8	3
24.	23P8OOC	Round washer 8 galv., 82005 82005	8
25.	23P10 82.005	Round washer 10 galv., 82005 82005	5
26.	23P6OOC	Round washer 6 galv., 82005 82005	1
27.	23P12OC	Round washer 12 galv., 82005	4
28.	23N6OC	Nut M6 galv. 82144 5 82144 5	2
29.	23NS12OC	Self-locking nut M12 galv., 82175 8 82175 8	3
30.	POD-ELZ-000051-1	Bolt 10 x 50 galv., 8.8 82101	1
31.	23S10/40 8.8 82105 OC.	Bolt 10 x 40 galv., 8.8 82105 82105	1
32.	23S12/55OC	Bolt 12 x 55 galv., 8.8 82101 82101	1
33.	23S8/25OC8.8	Bolt 8 x 25 galv., 8.8 82105 82105	1
34.	23S8/70OC	Bolt 8 x 70 galv., 8.8 82101 82101	1
35.	23S6/20	Bolt 6 x 20 galv., 8.8 82105 82105 8.8	2
36.	23W6/30OC	Screw 6 x 30 galv., 82208 82208	1
37.	23S12/45OC	Bolt 12 x 45 galv., 8.8 82105 82105	1
38.	23N12OC	Nut M12 galv., 82144 5	4
39.	23S8/35OC 8.8	Bolt 8 x 35 galv., 8.8 82105 82105	1
40.	23N8OC	Nut M8 galv., 82144 82144 5 82144	2
41.	23S6/60OC 8.8	Bolt 6 x 60 galv., 8.8 82101 82101 8,8	3

14. HYDRAULICS – WORKING TABLE LOCK

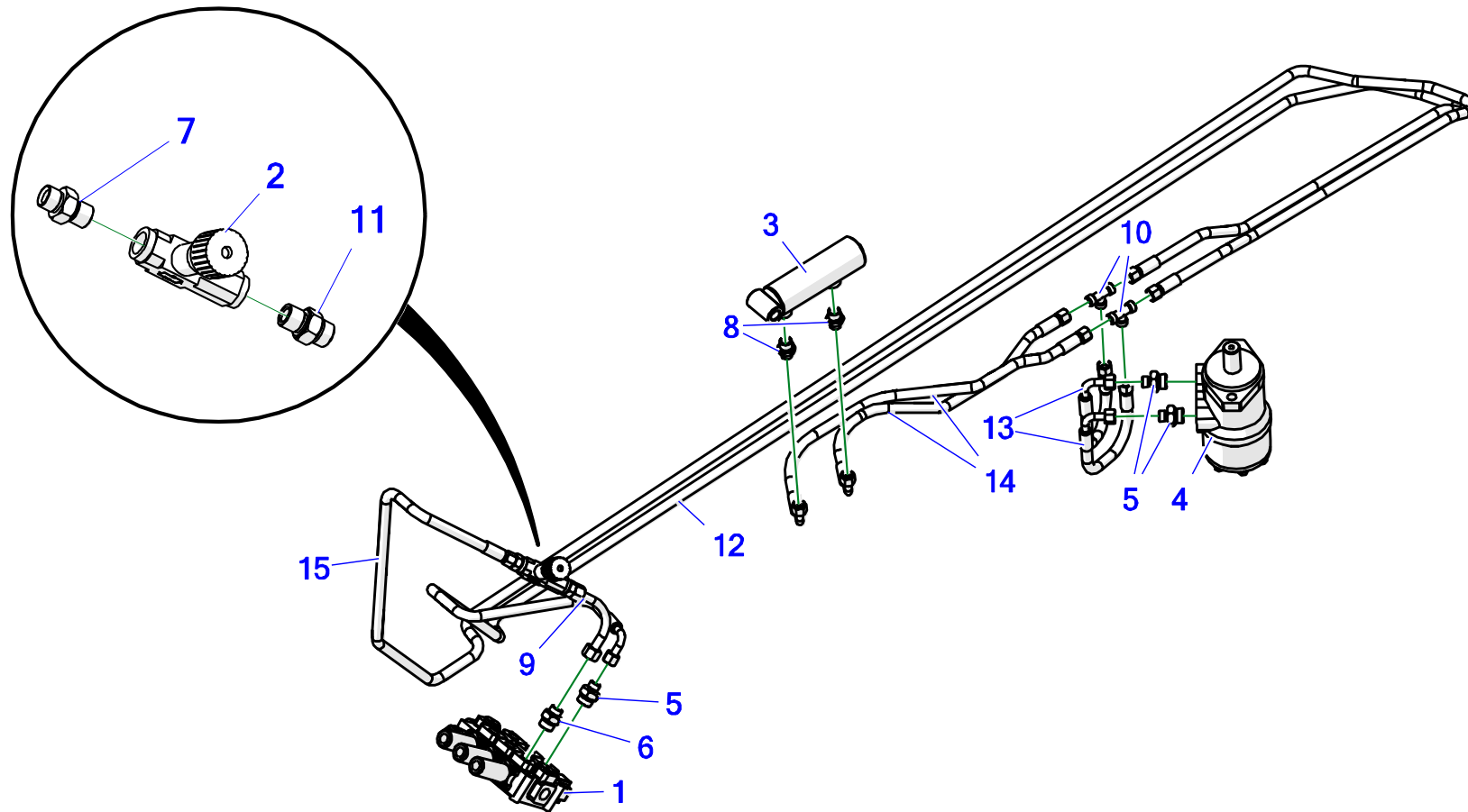

Table 14. Hydraulics – working table lock

No.	No.	Part or assembly name	Volume
1.	24RMD3 ROPE	MD3 rope distributor Q45	1
2.	24ZD	Throttle check valve VRFU 90-3/8"	1
3.	24SCJ2F40/22/65	Actuator 40/22/65*L-180	1
4.	24S200	OMR 200 (BMR) hydraulic motor	1
5.	24KP1/2 16	Straight connection 1/2 edx16-1.5	3
6.	24KP1/2 18	Straight connection 1/2 edx18-1.5	1
7.	24KP3/8 16	Straight connector 3/8 x 16-1.5	1
8.	POD-HKR-000076	Straight connector 18 x 1.5 - 16 x 1.5	2
9.	24KZ18/18	Angle nipple 18/18 x 1.5 (short tube)	1
10.	24KT16/16/16	Tee connector 16 x 16 x 16 10L	2
11.	24KP3/8 18	Straight connector 3/8 x 18-1.5 12LR	1
12.	POD-HPR-000187	A90A/111/8 L=3100 Z-2370M (1-2) cpl.	1
13.	POD-HPR-000187	A90A/111/8 L=300 Z-2370M (2
14.	POD-HPR-000187	A90A/111/8 L=700 Z-2370M (2
15.	POD-HPR-000187	AA/111/8 L=3000 Z-2370M (1-2) cpl.	1

15. HYDRAULICS – LIFTING AND LOWERING THE LOADING ARM

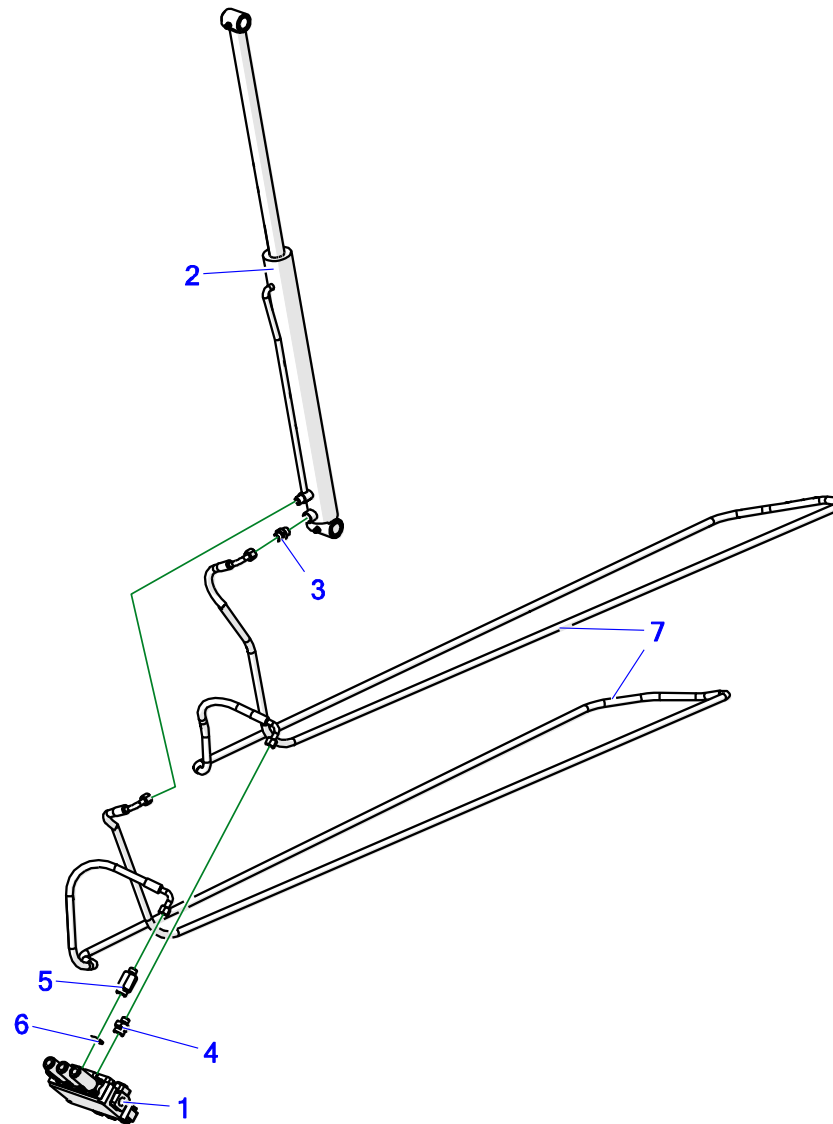

Table 15. Hydraulics – lifting and lowering the loading arm

No.	No.	Part or assembly name	Volume
1.	24RMD3 ROPE	MD3 rope distributor Q45	1
2.	24SCJ2F50/32/500	Actuator 50/32/500*L-720	1
3.	POD-HKR-000076	Straight connector 18 x 1.5 - 16 x 1.5	1
4.	24KP1/2 16	Straight connection 1/2 edx16-1.5	1
5.	24K1/2-16X1.5 L-59	Straight connector 1/2 16 x 15 L-59	1
6.	POD-HPZ-000044-1	Metal & rubber washer PPM 1/2"	1
7.	POD-HPR-000187	AA90/111/8 L=4600 K180	2

16. HYDRAULICS – LIFTING AND LOWERING THE MOBILE FRAME

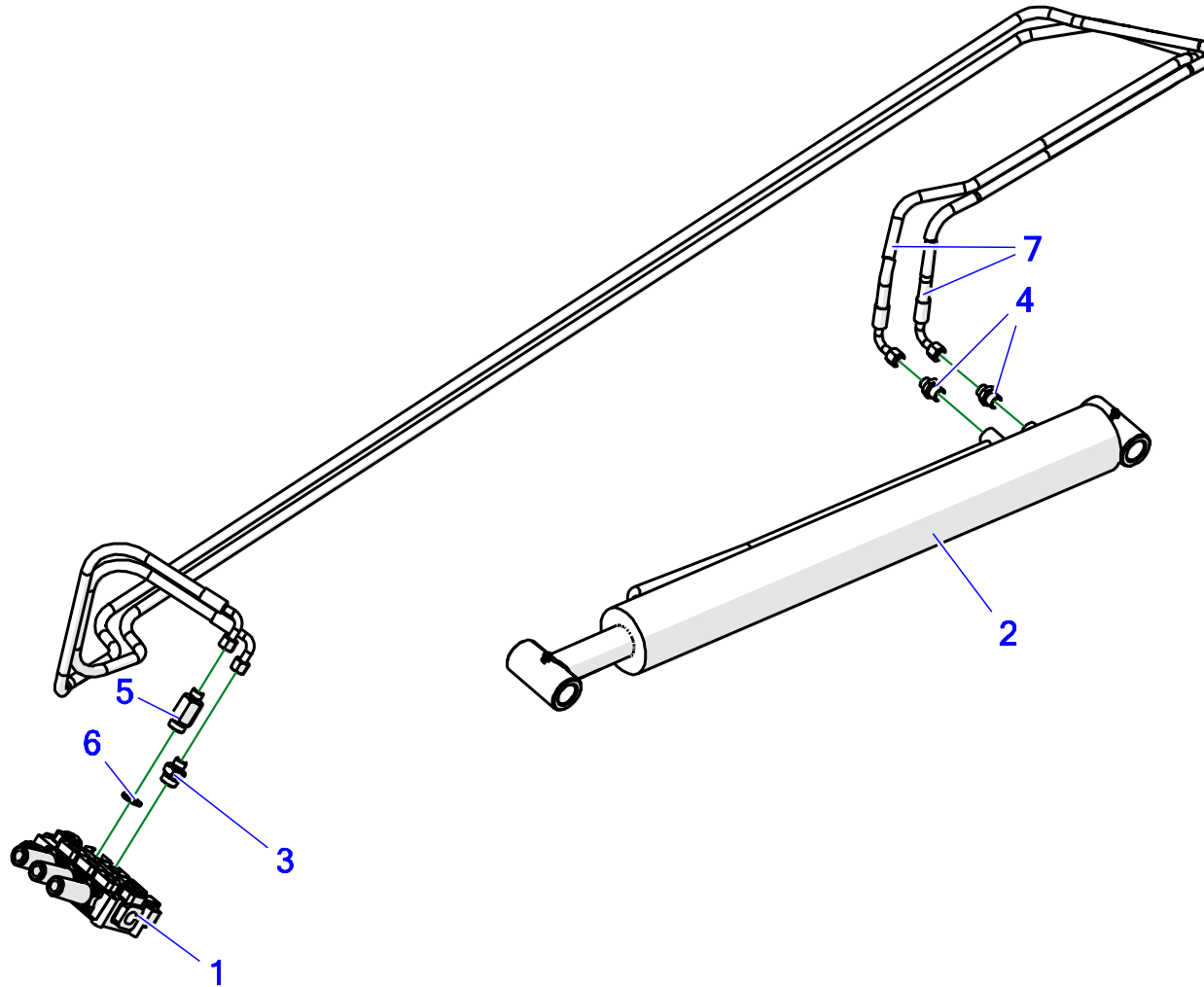

Table 16. Hydraulics – lifting and lowering the mobile frame

No.	No.	Part or assembly name	Volume
1.	24RMD3 ROPE	MD3 rope distributor Q45	1
2.	24SCJ2F80/45/610	Actuator 80/45/610*L-965	1
3.	24KP1/2 16	Straight connection 1/2 edx16-1.5	1
4.	POD-HKR-000076	Straight connector 18 x 1.5 - 16 x 1.5	2
5.	24K1/2-16X1.5 L-59	Straight connector 1/2 16 x 1.5 L-59	1
6.	POD-HPZ-000044-1	Metal & rubber washer PPM 1/2"	1
7.	POD-HPR-000187	AA90/111/8 L=3400 K90	2

17. HYDRAULICS – CONTROL LEVERS

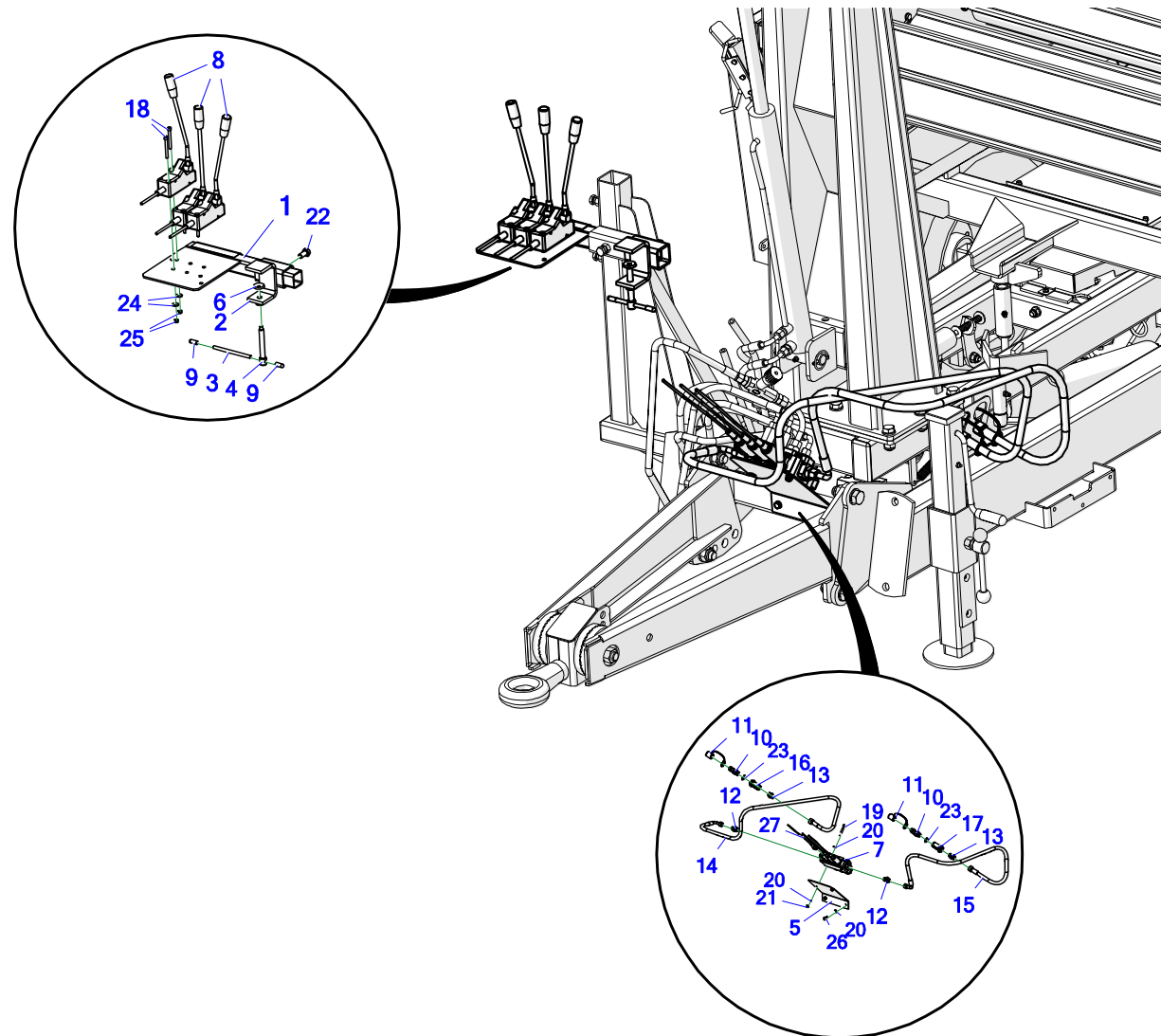
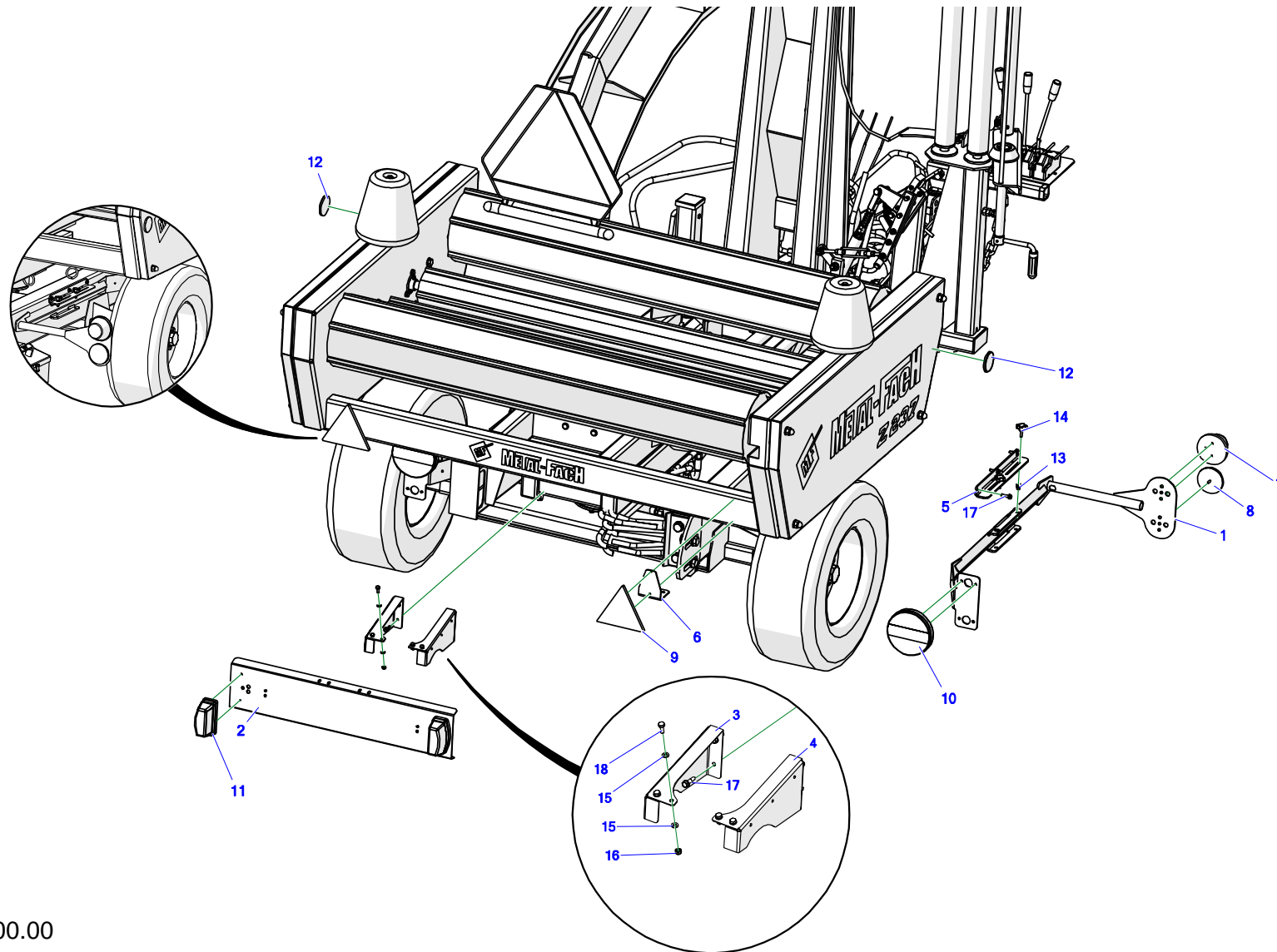

Table 17. Hydraulics – control levers

No.	No.	Part or assembly name	Volume
1.	Z-237 00.13.00	Separator device support	1
2.	Z-237 00.54.10	Handle body	1
3.	Z-237 00.54.04	Knob	1
4.	Z-237 00.54.30	Special bolt	1
5.	Z-577 00.17.01.1	Separator device support	1
6.	Z-237 215.000.004	Cap	1
7.	24RMD3 ROPE	MD3 rope distributor Q45	1
8.	24DZS	Rope controller lever	3
9.	POD-TSZ-000142	Round plug, ext. 9.8 mm black (Es-12888)	2
10.	24ZWE13	EURO 13 plug valve, M22 x 1.5	2
11.	24ZWNE13	Cap for EURO valve plug 13 (green, yellow, blue, red)	2
12.	24KP1/2 18	Straight connection 1/2 edx18-1.5	2
13.	24K1/2 22	Straight connector 1/2 edx22-1.5 15L	2
14.	POD-HPR-000187	A90A/114/10 L=2000 Z-2370M (2) cpl.	1
15.	POD-HPR-000187	A90A/114/10 L=2000 Z-2370M (1) cpl.	1
16.	POD-HPZ-000309	EURO plug marking holder green +	1
17.	POD-HPZ-000310	EURO plug marking holder green -	1
18.	POD-ELZ-000993	Allen bolt 6 x 55 galv., 8.8 82302	6
19.	23S8/60OC 8.8	Bolt 8 x 60 galv., 8.8 82101 82101	2

No.	No.	Part or assembly name	Volume
20.	23P8OOC	Round washer 8 galv., 82005 82005	6
21.	23NS8OC	Self-locking nut M8 galv., 82175 8 82175 8	2
22.	23S12/25OC 8.8	Screw 12 x 25 galv., 8.8 82105 82105	1
23.	24UPPM22	Metal & rubber washer, PPM22 30 x 22	2
24.	23P6OC030	Round washer 6 galv., coated 82030	6
25.	23NS6OC	Self-locking nut M6 galv., 82175 8 82175 8	6
26.	23S8/20OC 8.8	Bolt 8 x 20 galv., 8.8 82105 82105	2
27.	24LS2,5M	Control rope L-4500	3

18. LIGHTS



Z-237 09.00.00

Table 18. Lighting

Electrics and lighting cpl. – Z237 09.00.00

No.	No.	Part or assembly name	Volume
1.	Z-237 09.01.10	Lighting bar, welded	2
2.	Z-237 09.03.01	License plate bracket	1
3.	Z-237 09.03.02	License plate bracket, left	1
4.	Z-237 09.03.03	License plate bracket, right	1
5.	Z-237 09.00.02	Adjustment angle	2
6.	Z-237 09.00.01	Reflective triangle support	2
7.	26LP	Front position light WE92-12z	2
8.	POD-ELK-000089	Round reflector, white	2
9.	26TO	Reflective triangle red HOR14 UOT024 (IIIA-E9-02 16093)	2
10.	POD-ELK-000308	Rear combination light W95 (744) with 200 cm YLY-S 4 x 0.75 mm cable	2
11.	POD-ELK-000237	Licence plate light WO8-48	2
12.	POD-ELK-000339	Round reflector orange No. 844	2
13.	POD-ELZ-000001-1	Flanged cylindrical rivet nut With knurled shank M6 x 14 FE	4
14.	POD-KAB-000030-1	Knob P1M6 x 20	4
15.	23P6OOC	Round washer 6 galv., 82005 82005	8
16.	23NS6OC	Self-locking nut M6 galv., 82175 8 82175 8	4
17.	28W6,3X25 OC	Screw, self-drilling, 6.3 x 25 galv., hex head	10
18.	23S6/16 8.8OC	Bolt 6 x 16 galv., 8.8 82105 82105 8.8	4

*Lighting harness – POD-ELK-000535

*Bulb in the front parking light – 26Z12V21/5W

19. HITCH PROTECTION (EU APPROVAL) AND CONTAINER

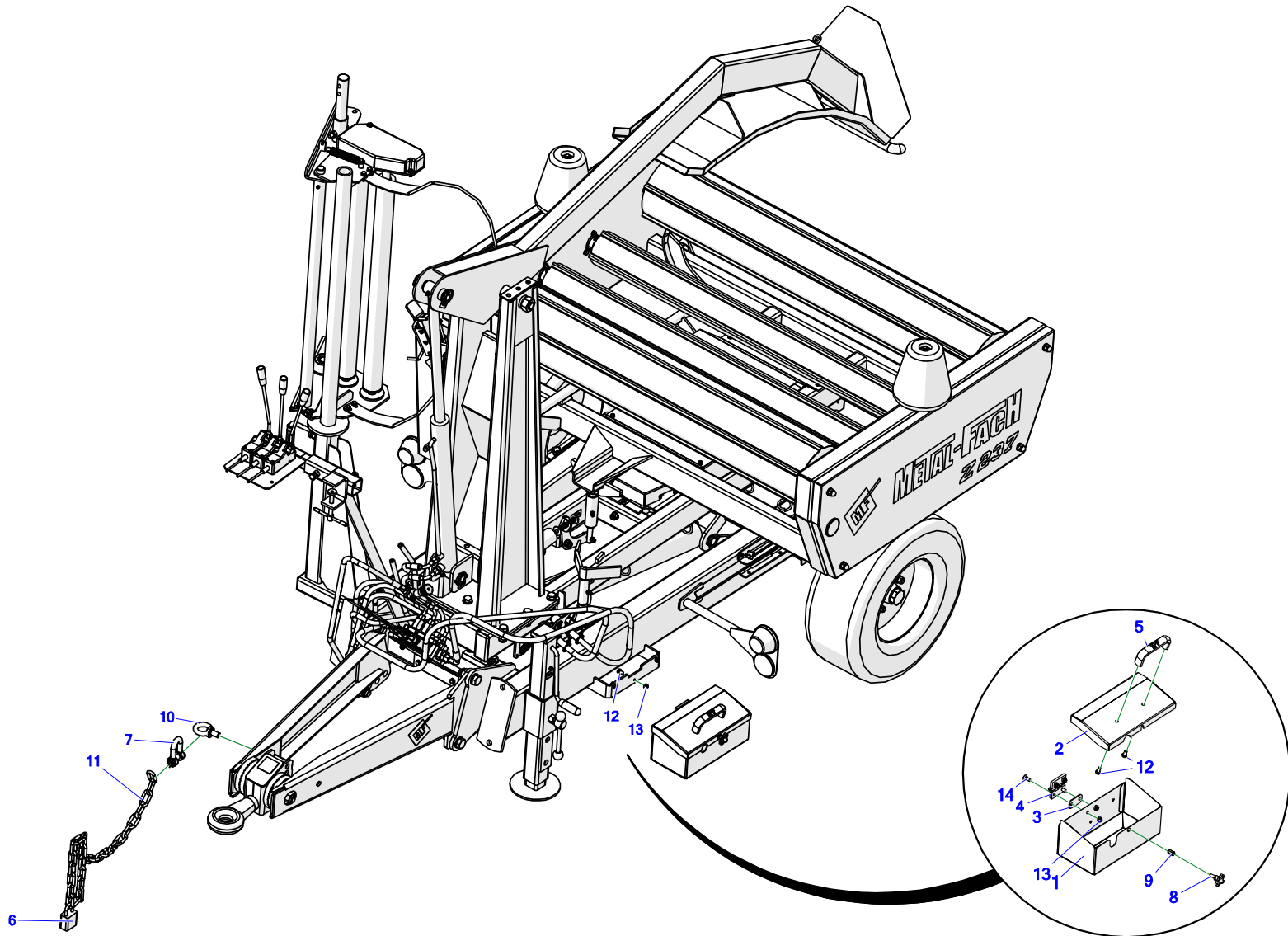

Table 19. Hitch protection (eu approval) and container

No.	No.	Part or assembly name	Volume
1.	Z593-1E 06.06.10	Container I	1
2.	Z593-1E 06.06.2020	Container lid	1
3.	Z593-1E 06.06.01	Hinge spacer	1
4.	POD-OGL-001047	Hinge N272 3.511.12 60 x 60, plastic	1
5.	POD-TSZ-000195	Panel holder 465934	1
6.	POD-OGL-001109	Hitch padlock	1
7.	POD-ELZ-000477	Shackle, 16 mm	1
8.	POD-OGL-000259	Knob P2M8 x 20	1
9.	POD-ELZ-000558	Blind rivet nut M8 steel Hexagonal	1
10.	POD-ELZ-000818	Eye bolt M16 galv. DIN580	1
11.	23LSFI8OC	General purpose chain 8 mm galv., 8 x 30 x 50 (0.7 m Z560)I	1
12.	23S8/16 8.8 82105 OC.	Bolt 8 x 16 galv., 8,8 82105 82105	5
13.	23NS8OC	Self-locking nut M8 galv., 82175 8 82175 8	7
14.	23W8/20OC	Screw 8 x 20 galv., 82208 8208	4

NOTES

A series of 20 horizontal dotted lines for taking notes.



Metal-Fach Sp. z o.o. is constantly improving its products and adjusting its package to the needs of its customers, so it reserves the right to make changes to its product range without notice. Therefore, before making your purchase decision, please contact an authorised dealer or sales representative of Metal-Fach Sp. z o.o.

Metal-Fach Sp. z o.o. will not accept any complaints regarding the data and pictures contained in the catalogue, as the presented range of products does not constitute an offer within the meaning of the provisions of the Civil Code.

The pictures do not necessarily show standard accessories.

Original spare parts are available from authorised dealers, both in Poland and abroad, and also at the Metal-Fach retail outlet.

TECHNICAL SERVICE

16-100 Sokółka, ul. Kresowa 62

Phone: +48 85 711 07 80; Fax: +48 85 711 07 93
serwis@metalfach.com.pl

SALES

16-100 Sokółka, ul. Kresowa 62

Phone: +48 85 711 07 78; Fax: +48 85 711 07 89
handel@metalfach.com.pl

SPARE PARTS WHOLESALE STORE

16-100 Sokółka, ul. Kresowa 62

Wholesale:

Phone: +48 85 711 07 80; Fax: +48 85 711 07 93
serwis@metalfach.com.pl

Retail

Phone: +48 85 711 07 80; Fax: +48 85 711 07 93
serwis@metalfach.com.pl