



# METAL-FACH



## BALE WRAPPER Z577

INSTRUCTIONS MANUAL – PART II  
TRANSLATION OF THE ORIGINAL INSTRUCTIONS MANUAL  
REVISION I  
NOVEMBER 2018



## Spis treści

### CZĘŚĆ I

WSTĘP.....	9
1. Informacje podstawowe .....	11
1.1 Wprowadzenie.....	11
1.2 Identyfikacja owijarki .....	11
1.3 Użytkowanie zgodnie z przeznaczeniem .....	14
1.4 Budowa owijarki .....	15
1.5 Charakterystyka owijarki.....	16
1.6 Wymiary owijarki .....	18
1.7 Usytuowanie piktogramów.....	19
1.8 Symbole ostrzegawcze.....	20
2. Bezpieczeństwo użytkowania.....	23
2.1 Obowiązek informacji .....	23
2.2 Ogólne zasady bezpieczeństwa .....	23
2.3 Współpraca z ciągnikiem.....	26
2.3.1 Łączenie z napędem.....	28
2.3.2 Odłączenie od napędu.....	30
2.4 Wyposażenie dyszla.....	31
2.5 Instalacja oświetleniowa .....	32
2.6 Instalacja hydrauliczna .....	33
2.7 Pierwsze uruchomienie .....	35
2.7.1 Pierwsze uruchomienie licznika .....	37
3. Elementy sterowania i regulacji bieżącej.....	38
3.1 Rozmieszczenie elementów regulacji bieżącej .....	38
3.2 Dźwignie sterowania .....	39
3.3 Podajnik folii .....	40
3.4 Stopa podporowa .....	41
3.5 Regulacja wysokości zaczepu .....	42
3.6 Zmiana pozycji koła jezdnego.....	43
3.6.1 Odblokowanie pozycji półosi.....	43
3.6.2 Zablokowanie pozycji półosi .....	43
3.6.3 Robocza pozycja koła jezdnego .....	44
3.6.4 Transportowa pozycja koła jezdnego.....	45
3.7 Zestaw hydraulicznego przestawiania koła jezdnego .....	46

3.8	Regulacja szerokości stawiacza bel .....	47
3.9	Regulacja wysokości czujnika zliczającego obroty .....	47
3.10	Regulacja szerokości ramienia załadowniczego .....	48
3.11	Regulacja napięcia łańcuchów .....	49
3.11.1	Regulacja łańcucha napędowego stołu roboczego .....	49
3.11.2	Regulacja łańcucha przekładni bębnow stołu roboczego .....	50
3.11.3	Regulacja łańcucha przekładni podajnika folii .....	51
3.12	Przystosowanie do owijania folią 500 mm .....	52
3.12.1	Przystosowanie przekładni stołu roboczego do folii 500 mm .....	52
3.12.2	Przystosowanie podajnika do folii 500 mm .....	52
3.13	Zawory regulacyjne .....	53
3.13.1	Zawór regulacji blokady stołu obrotowego .....	54
3.14	Regulacja mechanicznego obcinacza folii .....	55
3.15	Regulacja hydraulicznego obcinacza folii .....	57
3.15.1	Regulacja wysokości obcinacza .....	57
3.15.2	Regulacja pozycji uruchamiania obcinacza .....	58
3.15.3	Napełnianie akumulatora hydraulicznego .....	59
3.16	Pozycja transportowa i robocza oświetlenia przedniego .....	60
	INDEKSY NAZW I SKRÓTÓW .....	61
	INDEKS ALFABETYCZNY .....	62
	NOTATKI .....	64

## PART II

4.	Bale-Wrapper operation .....	8
4.1	Preparing bales .....	8
4.2	Film installation .....	8
4.3	Wrap Counter .....	8
4.3.1	Switching the counter on and off .....	9
4.3.2	Rotation sensor .....	10
4.3.3	Setting the wind number .....	11
4.3.4	Wrap-number calculating method .....	11
4.3.5	Selecting fields .....	11
4.3.6	Counting-mode operation .....	12
4.4	Working position .....	13
4.5	Servicing cycles of the Bale Wrapper .....	15
4.5.1	Bale loading .....	17
4.5.2	Wrapping .....	18
4.5.3	Unloading the wrapped bale .....	20
4.5.4	Mechanical film cutting .....	22
4.5.5	Hydraulic film cutting .....	24
4.6	Film breaking .....	25
4.7	End of operation – the Bale Wrapper transporting position .....	26
5.	Operation and maintenance activities .....	27
5.1	Cleaning .....	28
5.2	Machine maintenance .....	29
5.3	Scheduled Inspections .....	29
5.4	Metrical-bolt tightening torques .....	30
5.5	Lubrication interval .....	31
5.6	Lubrication points .....	32
6.	Authorised service .....	33
6.1	Guarantee service .....	33
6.2	Routine service .....	33
6.3	Ordering spare parts .....	33
7.	Wrapper transporting .....	34
7.1	Road-Traffic Participant .....	34
7.1.1	The Bale tipper's transporting position .....	36

7.1.2	Securing the loading arm .....	36
7.2	The Tractor's and Bale-Wrappers stability .....	37
7.3	Load transporting.....	38
8.	Wrapper storage .....	39
9.	Residual Risk .....	40
9.1	Residual-risk descriptions .....	40
9.2	The Assessment of Residual Risk .....	40
10.	Wrapper disposal .....	41
11.	Typical faults and troubleshooting .....	42
12.	Accessories.....	45
	INDEX OF NAMES AND ABBREVIATIONS.....	46
	ALPHABETICAL INDEX .....	47
	NOTES .....	49

## The symbols used in these Instructions



**DANGER**

Hazard-warning symbol. This indicates the occurrence of a serious hazard condition, which, if not avoided, can result in death or serious injury. This symbol warns against the most-dangerous situations.



**CAUTION**

This symbol points to especially important information and recommendations. Non-compliance with the described recommendations risks serious damage to the machine due to its incorrect operation.



**WARNING**

This symbol indicates the possibility of the occurrence of a hazard, which, if not avoided, can result in death or serious injury. This symbol indicates a lower level of risk of injury than the symbol including the word "DANGER".



This symbol indicates useful information.



This symbol indicates maintenance activities which should be performed periodically.

## 4. Bale-Wrapper operation

### 4.1 Preparing bales

Use balers to bale dried grass and other papilionaceae with a humidity of ca 60%. Ensure the bales are of regular tubular shape and appropriate compaction degree – see the Instructions Manual for the Baler.

Wrap bales in the field or in a yard intended for their storage, preferably virtually right after having baled them. Stack the wrapped bales in not more than two layers on a dry and smooth surface and verify the bales for full coverage with the wrapping film.

Leave the bales to ferment for 6 to 8 weeks in temperatures above zero. The haylage so made can be used to feed animals as wholesome fodder.

### 4.2 Film installation

Follow the below procedure to mount the film roll in the film feeder.

- Tilt the foil roll bracket and secure it with a hook attached to the pre-stretching unit
- Use the handwheel (crank) to unwind the lower pin clamping the film
- Set the height of the upper pin at the position corresponding to the film roll width of 500 mm or 750 mm
- Fit the film roll on the upper cone pin and press against the spring to embed the roll on the lower cone
- Wind the lower pin with the handwheel (crank) to tighten the roll which ensures its firm vertical retention
- Use the nut on the crank screw to secure the roll against spontaneous unwinding
- Install the film with its external gluey side towards the bale axle
- Drag the film band over the pre-stretchers following the diagram on the information pictogram (Fig. 18, Fig. 45).
- Once you have dragged the film band over the pre-stretchers, remove the hook which secures the film roll frame.
- Attach the end of the film band to a loaded bale.

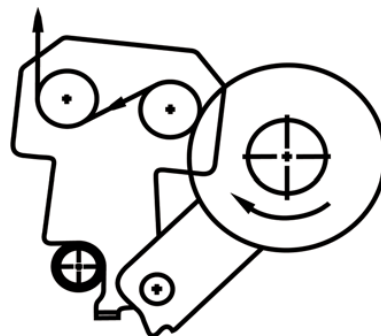

**Figure 45.** Film-flow diagram – top view

### 4.3 Wrap Counter

The L-02 wrapping counter is an electronic device which counts and informs the user about the number of turntable revolutions made, the end of wrapping, the number of bales wrapped, and statistics on efficiency and work time.





The counter is an electronic device used to count the bale wraps and can be used in all types of lever-controlled Wrappers.



Install the revolution counter in the tractor cab and ensure good visibility and display access.



**Figure 46.** L-02 Wrap counter

Protect the counter against moisture and excessive vibrations, impacts on the cab structure, and falls on hard surfaces in particular. You can use the magnetic fitting on the back wall of the counter to fix it.

The counter unit includes counter software in a plastic casing, revolution sensor, wire bundle, and multi-contact connection.



**CAUTION**

**CAUTION!**

Do not expose the counter to moisture, chemical agents, direct precipitation, frost, temperature over 500°C, or the strong effects of sunlight.

**4.3.1 Switching the counter on and off**

A flashing red light on the display indicates the correct configuration of the rev-counter system.

Press and hold the ON push button marked with letter C to switch on the counter. Each time the counter is switched on, the display and power supply are tested (Section 2.7.1). A positive counter test indicates that it is ready for operation using the settings entered during a previous activation.

Press and hold the OFF push button marked with letter C to switch off the counter until a red flashing light appears on the display (for approx. 3 seconds). You can disconnect the counter unit system after this signal.

#### 4.3.2 Rotation sensor

Use the lighter socket plug to connect the rotation sensor, which is installed in the tractor cab, to a power supply (12V), and a dedicated wire bundle to connect it to the revolution counter.

Mounted on a fixed section of the Bale Wrapper, the rotation sensor works with a fixed magnet fitted on the rotative frame to transmit pulses to the revolution counter. Each bale revolution is counted and shown on the revolution counter display.

After a pre-set number of revolutions is counted, the counter signals wrapping is stopped by emitting a sound.

The counter can be pre-set to wrap from 10 to 49 times.



**CAUTION**

**CAUTION!**

Protect the installed wire bundle which connects the revolution sensor to the revolution counter against accidental mechanical damage.



**CAUTION**

**CAUTION!**

Protect the wire bundle plug connected to the revolution counter against accidental disconnection.

### 4.3.3 Setting the wind number

- Press F1 i F2 simultaneously Previous settings are displayed The change enter mode is signalled by simultaneous lighting of the red LED – attention, and the green LED – wrapping
- Change the wrap number by pressing F2 choosing from the range 10-49
- Press C to confirm the change
- The counter is ready to work with a new setting.

### 4.3.4 Wrap-number calculating method

A formula for calculating the number of turntable revolutions N

$$N_T = L \times D \times k$$
$$N = [N_T]$$

$N_T$  – the theoretical number of turntable revolutions

N – the target number of turntable revolutions

D – bale diameter [m]

L – film layers on a bale (2, 4, 6...)

k = 5.23 – elongation coefficient for the 750mm film

k = 7.85 – elongation coefficient for the 500mm film

To calculate the target number of turntable revolutions N, multiply your required number of film layers L by the bale diameter D and the elongation coefficient k which is suitable for the film width used for wrapping.

Then, round the result obtained up to the next whole number.





### 4.3.5 Selecting fields

- Press F1 to change the field number (1,2,3).
- Press F2 to change the indication of bales stored on a field to a screen with the number of wraps and bales.
- Use F2 to display data on the average output of the Bale Wrapper per work hour and wrapped bale number.
- Once the number of the field is selected, you can delete the counter indications by pressing simultaneously F2 and C. The red flashing LED and continuous sound signal that you can enter your changes.
- Hold the push buttons pressed until the sound goes off.
- The counter indications of a field have been deleted.

#### 4.3.6 Counting-mode operation

- After the field is selected and the wrap number set, you can start work. The counter moves to the wrapping-indication options automatically after it receives pulses from the revolution sensor of the Bale Wrapper.
- After the pre-set number of wraps is reached, the counter display and the red LED flash alternately. The wrap is also signalled by an intermittent sound.
- Delete the signal of the wrapping end by pressing and holding C. Hold the push button until a number of wrapped bales is displayed and the red LED goes off.
- The counter is ready to count the wraps of another bale.

**Table 5.** Sample indication of the L-02 counter display

Icon displayed	Indication	Sample indication	Meaning
	Bale counter	16	12 bales wrapped on a field
	Time	3.25	Work hours 3 hrs and 25 min. on a field
	Output	3.5	3.5 bales wrapped per 1 hour on a field on average
	Wrapping	24.15	Wrap counter is set to 24 Bale wrap is 15 at the moment
	Warnings/Alerts	Err 1 lit flashing	Error No. 1

#### 4.4 Working position

Before you start the operation, shift the Bale Wrapper from the transporting to the servicing position.

- Park the tractor with the Bale Wrapper on level and solid ground
- Set the front lights to the working position (Section 3.16)
- Release the mechanical lock of the right axle shaft position (Section 3.6.1)
- Set the axle shaft to the service position (Section 3.6.3) or use the hydraulic cylinder, if present (Section 3.7).
- Engage the mechanical lock of the axle shaft position (Section 3.6.2)
- Lift the loading arm to its maximum height and set the arm pin in the unlocked, the transporting position (Fig. 47 – B).
- Lower the loading arm
- Set the bale tipper to the servicing position (Fig. 48).
- Remove the transporting protection of the tipper unit and place it in the holder on the tipper frame.

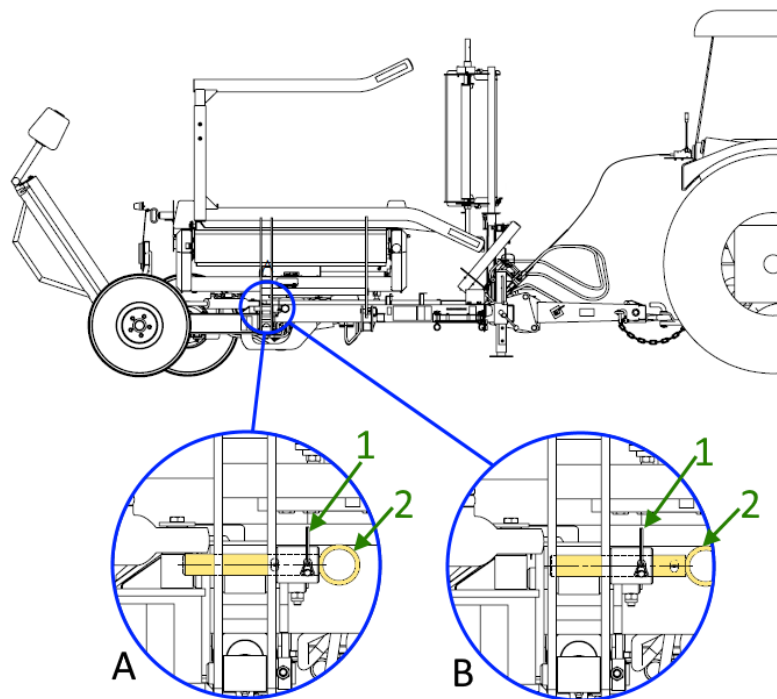

**Figure 47.** Locking the loading arm in place A – The transporting position; B – Service position; 1 – Locking pin, 2 – Pin

Follow the procedure below to set the bale tipper in the working position (Fig. 48).

- Remove the locking pin (1) from the pin (3) which retains the tipper in the transporting position
- Push the tipper toward the Bale Wrapper (2) and remove the retaining pin (3)
- Lower the tipper carefully until it rests on the spring (4)
- Put the pin (3) together its locking pin (1) away in the tractor's cab

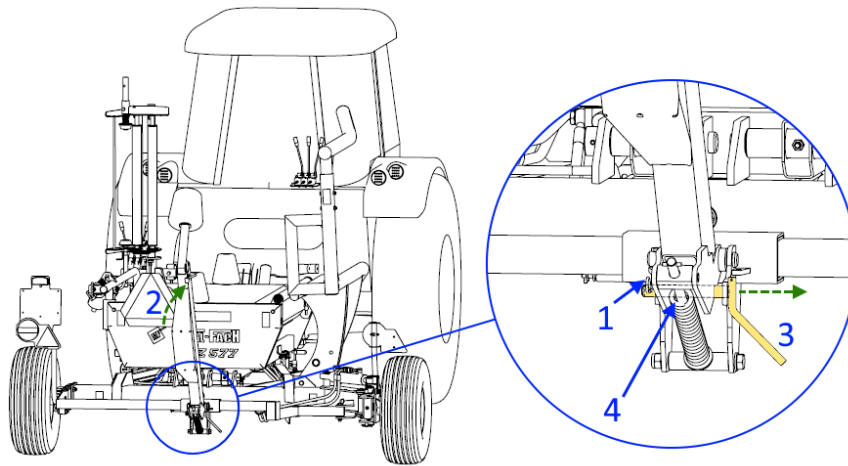

**Figure 48.** Bale-tipper servicing position

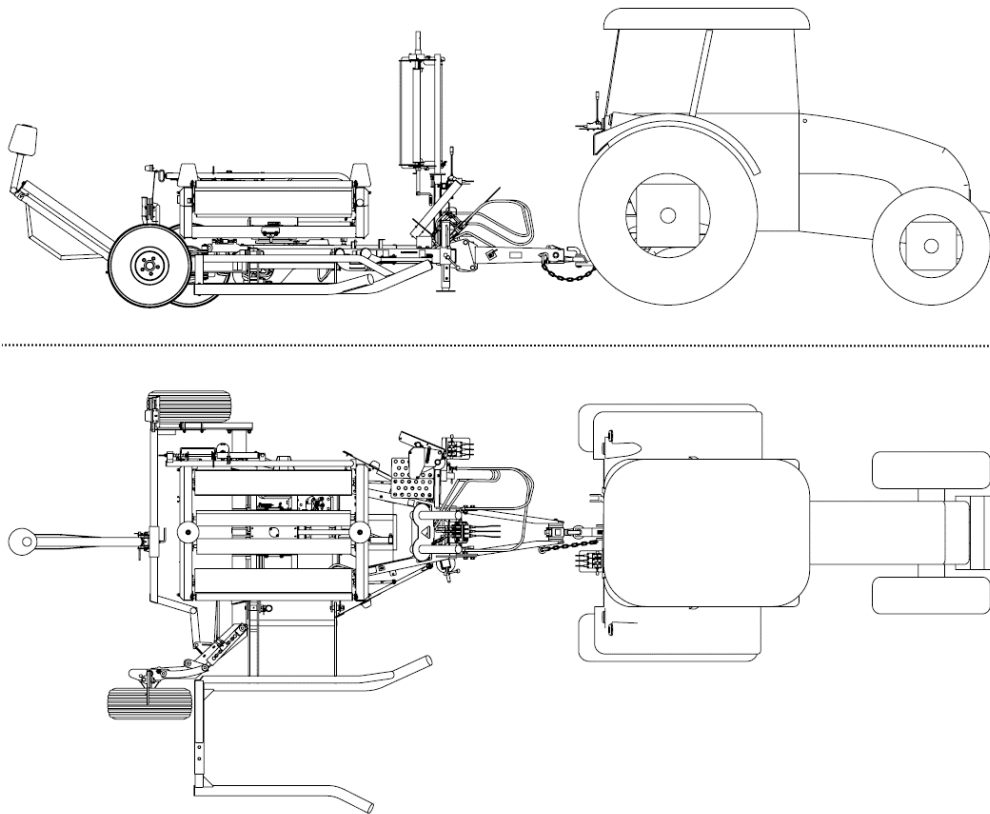

**Figure 49.** Servicing position of the Bale Wrapper



**WARNING**

**WARNING!**

Exercise caution when shifting the axle shaft and bale tipper. Risk of crushing hands.

#### 4.5 Servicing cycles of the Bale Wrapper

When operating the Bale Wrapper, follow the successive work cycles.

- Loading – a bale is picked up from the ground with the loading arm to load and leave on the service table (Section 4.5.1)
- Wrapping – a bale is rotated on the service table and wrapped in successive film layers (Section 4.5.2)
- Unloading – a wrapped bale is carried from the service table onto the bale tipper, and then rolled to the ground (Section 4.5.3)
- Gripping and cutting the film – this automatic action is made at the initial phase of the unloading action and involves a film band, which is stretched between the bale and the film feeder, to be gripped and cut off at the bale side (Section 4.5.4)



Wrap bales in temperatures above zero. Perform the wrapping on a field or in the bale-storage area.



Avoid unnecessary transporting to reduce the risk of damaging the film-covering bales.



**CAUTION**

#### CAUTION!

Before starting work, check

- the Bale Wrapper drawbar is connected to the tractor's hitch correctly
- correct connection of the power hydraulics
- correct connection of the revolution-counter system
- raising and lowering of the loading arm
- raising and lowering of the turntable frame
- the revolutions of the rotary frame and rollers are unobstructed and in the correct direction – the rotary frame is to rotate clockwise when wrapping
- turntable lock
- the studs of the Bale Wrapper's ground wheels are tightened



**WARNING**

**WARNING!**

Before you turn on the rotary-frame drive, ensure there are no bystanders in the machine-operation area.



**CAUTION**

**CAUTION!**

Maintaining the proper condition of the rollers, particularly their edges, reduces the risk of film breaks during wrapping.



**CAUTION**

**CAUTION!**

Never wrap bales during precipitation.



**CAUTION**

**CAUTION!**

Stop wrapping when bales are wrapped too tightly.  
Find the cause of the high film tension.  
Set the correct film tension. Resume bale wrapping.



**CAUTION**

**CAUTION!**

Do not operate the Bale Wrapper on slopes exceeding 8°.



### 4.5.1 Bale loading

Follow the procedure for bale loading (Fig. 50, 51).

- Lock the service table in the loading position, i.e. along the centre line of the Bale Wrapper with the cutter, on the left of the machine
- Drive the Bale Wrapper with its loading arm lowered so that the bale fits between the grab arms
- The longitudinal centre line of the Bale Wrapper (1) approaching the bale must remain parallel to that of the bale (2)
- Stop the tractor when the bale leans on the retaining surface of the loading arm (3)
- Raise the loading arm (4) until the bale rolls freely onto the turntable (5)
- Lower the loading arm (6) to its lower position

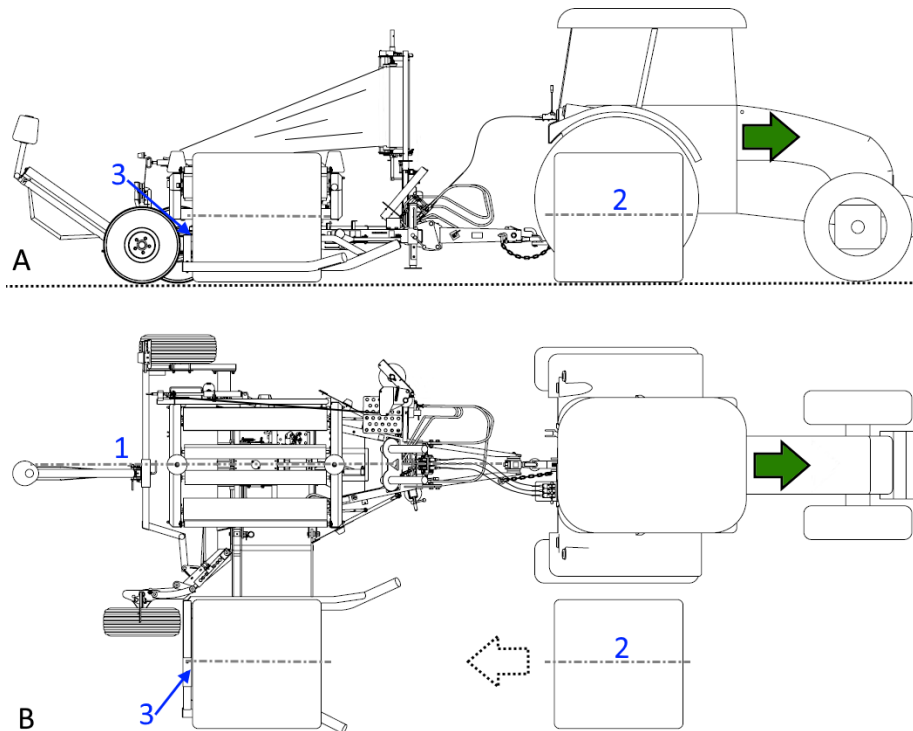

**Figure 50.** Bale-Wrapper position for bale loading A – right side view, B – top view

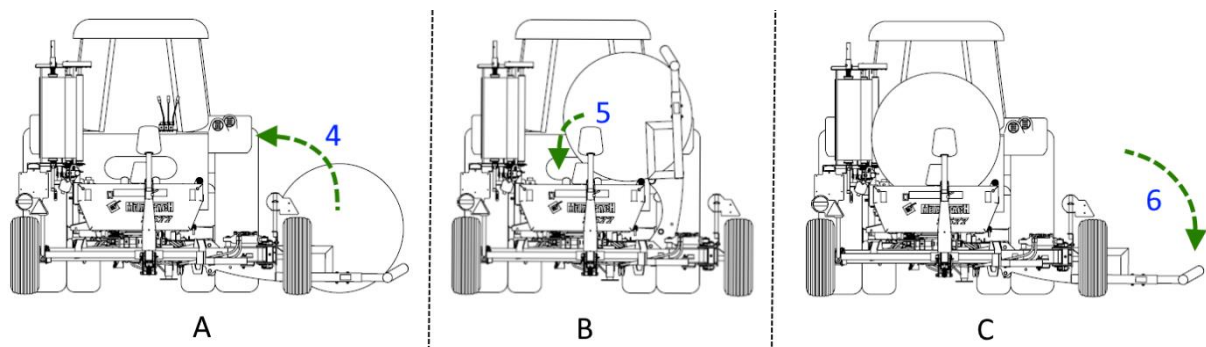
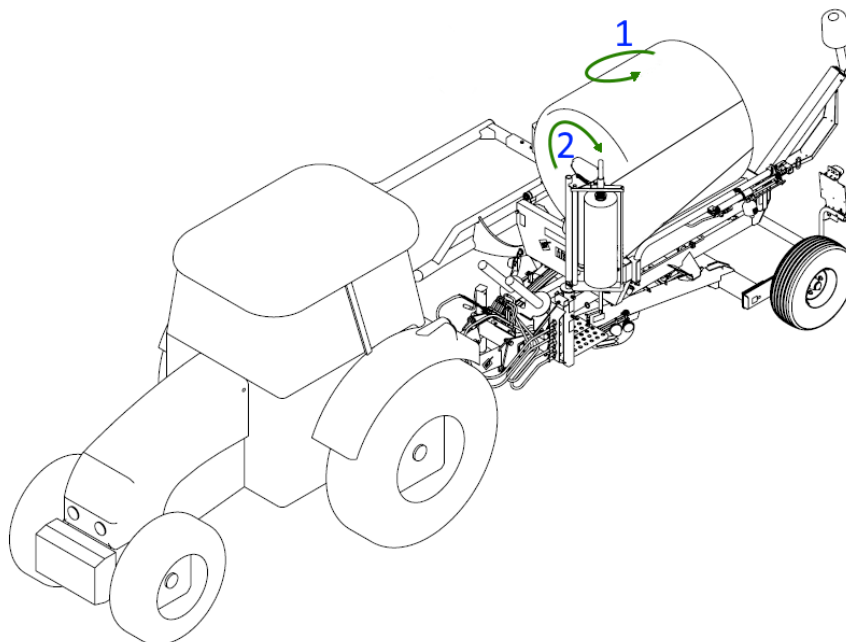

**Figure 51.** Bale loading A – Raising the loading arm, B – Passing the bale on to the service table, C – Lowering the arm

### 4.5.2 Wrapping

Follow the procedure for bale wrapping (Fig. 52, 53, 54)

- For the first bale, pull the film as far as possible away from the feeder and tie it to the bale with twine or a net for bale tying. For subsequent bales, the end of the film already rests in the cutter pick.
- Move the lever controlling turntable revolutions smoothly to switch on the drive of the Bale Wrapper's hydraulic motor in the wrapping direction (1) Make the two first revolutions with a lower speed than the wrapping speed
- With every revolution of the turntable, a bale which rests on it is simultaneously rotated around its horizontal centre line (2), which results in successive film layers being overlapping one another and the bale being tightly wrapped
- The side cones mounted on the sides of the rotary frame secure the bale against rolling from the rollers when being wrapped
- Wrap the bale maintaining the tractor-engine speed of 1,500 rpm Individual film layers should have a 50% overlap
- A continuous sound generated by the bale counter means the last revolution is being made – lower the service table's rotational speed smoothly
- Stop the service table at the position exceeding the initial position by ca 45° (3).
- Use the lever controlling table revolutions to steer in the opposite direction to the wrapping direction, which results in the position of the service table's being locked in the unloading position (4)
- When locking, shortening the cylinder (5) will cause the locking pin to move out (6) towards the bushing on the service table
- A locked service table will not move back further than to its unloading position
- Bales wrapped and counted can be confirmed on the counter – hold the C push button



**Figure 52.** Wrapping bales

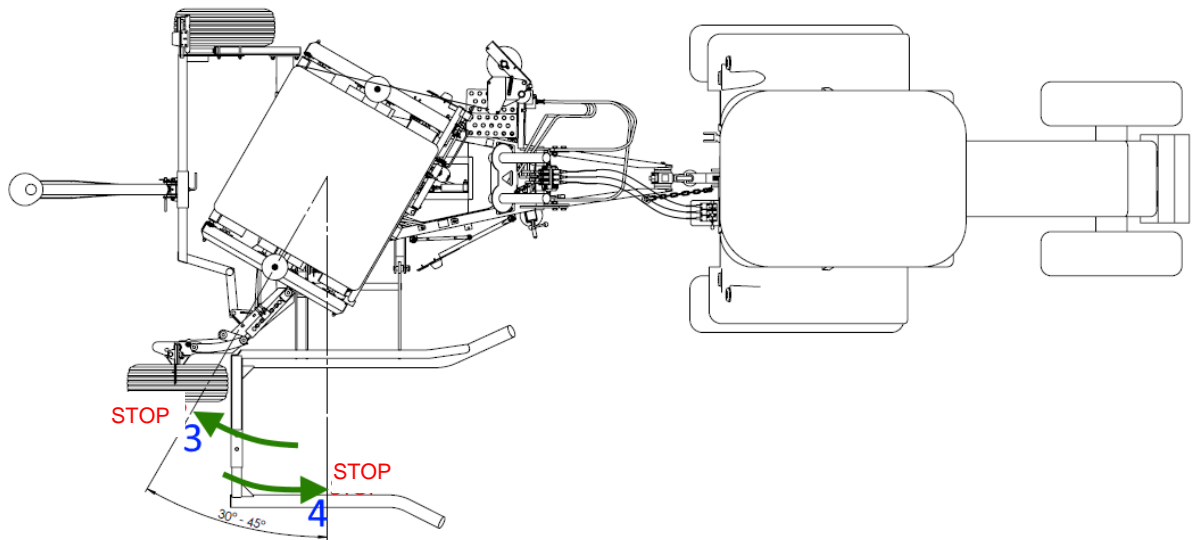

**Figure 53.** Stopping and locking the service table for unloading

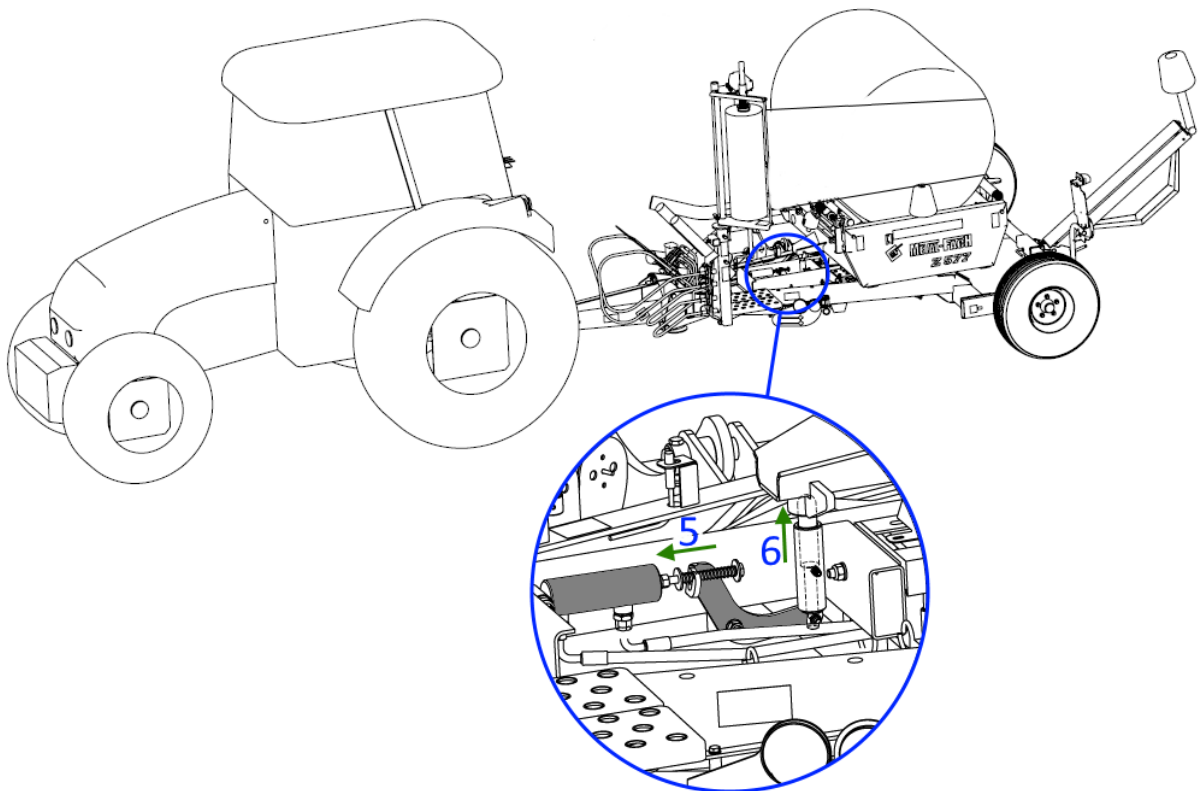
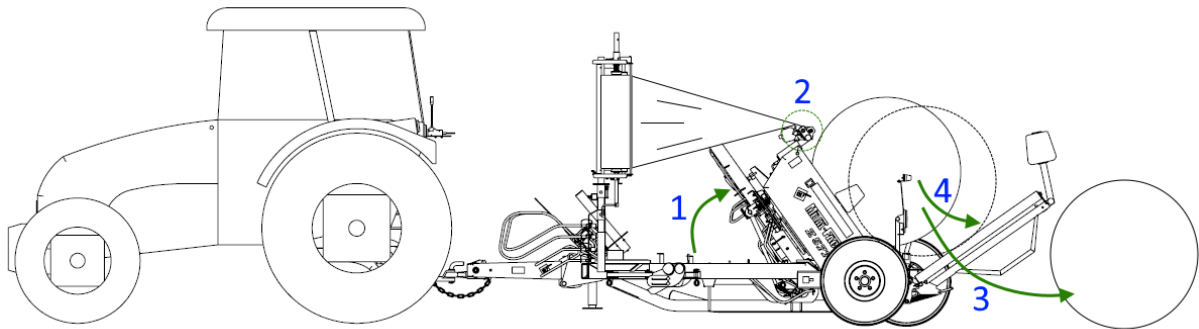

**Figure 54.** Locking the service table in the unloading position

### 4.5.3 Unloading the wrapped bale

Follow the procedure for bale unloading (Fig. 55, 56, 57)

- Make sure the turntable is locked so it does not move accidentally
- Use the control lever to raise the service-table frame (1)
- At the extreme point of raising the film should be grabbed and cut off (2)
- If the Bale Wrapper is fitted with a hydraulic film cutter, hold the control lever engaged from unloading until the film is cut off
- If the Bale Wrapper is fitted with a mechanical film cutter, you can release the control lever after the service table reaches its maximum position
- If the Bale Wrapper is not fitted with a bale tipper, a wrapped bale should roll from the service table to the ground (3)
- If the Bale Wrapper is fitted with a bale tipper, the wrapped bale should roll onto the tipper (4), which will rotate the bale (5) to the left side of the tipper and tip it onto the ground on its flat side (6)
- Lower the service table to the horizontal position (7)
- Rotate the service table to lock it in the loading position (8, 9)
- Drive away from the unloaded bale and take care not to damage it when doing so



**Figure 55.** Raising the service table and unloading a bale

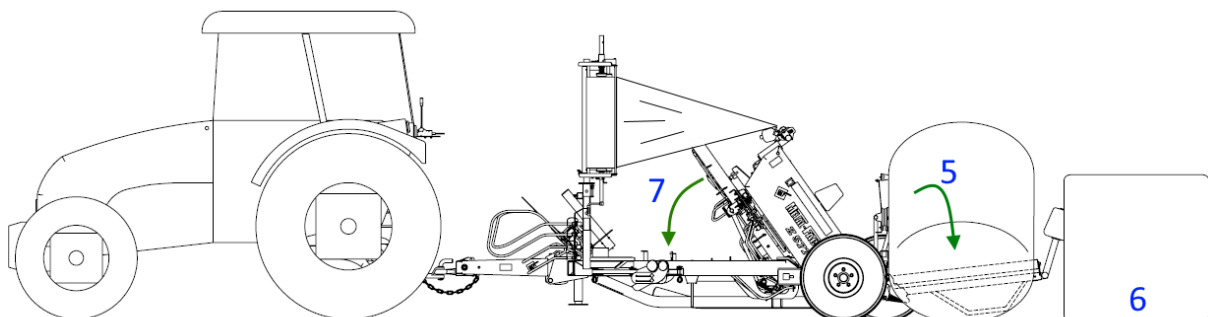

**Figure 56.** Unloading a bale using the bale tipper

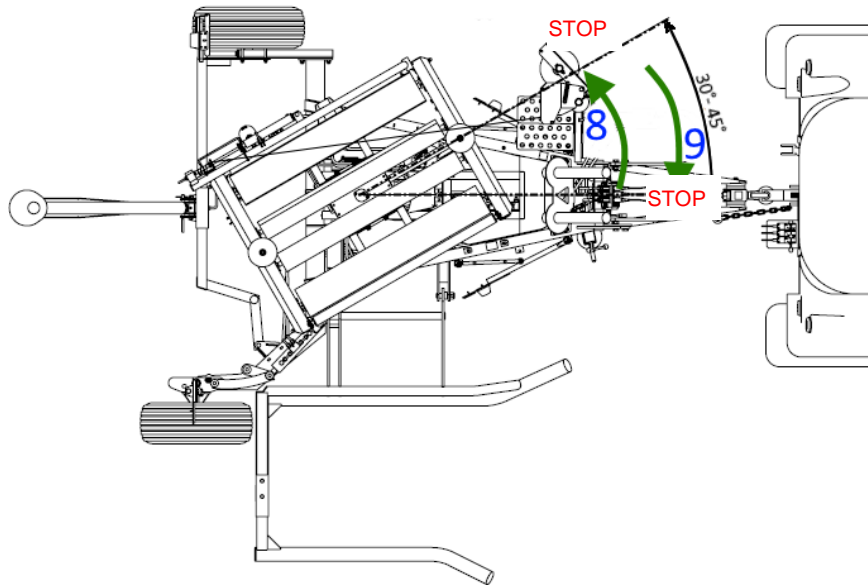

**Figure 57.** Locking the service table for loading



**CAUTION**

**CAUTION!**

Prior to unloading, ensure there are no bystanders in the unloading area.

A bale to be unloaded risks the crushing hazard.



**CAUTION**

**CAUTION!**

Unloading is allowed on a level and even surface only.

Unloading bales on slopes risks unforeseen behaviour of a bale, thus compromising safety

#### 4.5.4 Mechanical film cutting

Follow the procedure below to pick and cut the film (Fig. 58)

- At the initial unloading phase, when the service table is raised, the film band, stretched between the bale and the feeder, lands between the clamping surfaces (1)
- When the service table reaches its highest position, the lever (2), pulled by the chain (3), makes the cutter axle swivel (4)
- The swivelling movement of the cutter axle is interlocked with the movement of the cutter arm (5)
- Firstly, the cutter arm swivel, which has an articulated connection with the clamping device by means of a sprung rod (6), closes the clamp and the film is picked
- Then, the cutting blade which has an articulated connection link (7) with the cutter arm, swivels and cuts off the film between the clamping device and a bale
- This coincides with the rope's pulling the arm buffer (8), which moves back to its initial position

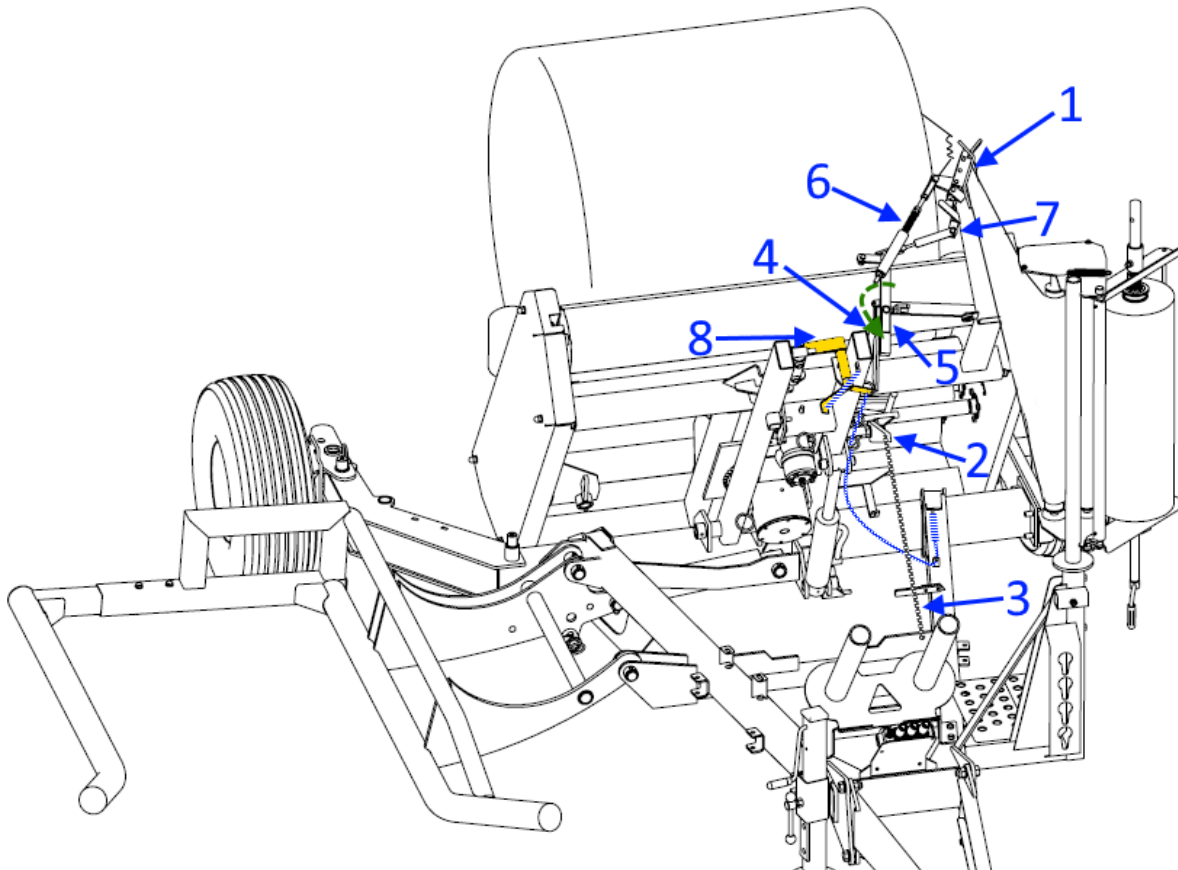

**Figure 58.** Grabbing and cutting the film

Releasing the film after the second revolution of the service table for the mechanical cutter.

- Immediately before the end of the first revolution, the cutter arm hits the arm buffer to make it turn and set in the locked position
- At the end of the second revolution, the cutter arm hits the surface of the locked buffer, and this impact makes the arm swivel on its axle in the opposite direction to the one during the cutter closing action
- The swivel of the cutter arm results in the clamping device and cutter blade opening
- In the open position, the cutter arm moves over the buffer to a height which does not allow their contact during subsequent turns



**CAUTION**

**CAUTION!**

Raising the service table which is not locked in the unloading position risks damage to the cutter unit.

Always lock the service table in the correct position before you start loading or unloading.



**CAUTION**

**CAUTION!**

The cutter must be closed when a bale is loading.



**WARNING**

**WARNING!**

In the event of hazard in terms of the Bale Wrapper operation lower the control levers of the hydraulic manifold. Stop the tractor engine, take the key from the ignition and engage the auxiliary brake of the tractor. Locate the hazard and rectify it.

#### 4.5.5 Hydraulic film cutting

Follow the procedure below to pick and cut the film (Fig. 58)

- At the initial unloading phase, when the service table is raised, the film band, stretched between the bale and the feeder, lands between the clamping surfaces (1)
- When the service table reaches its extreme position, the lever (2), pulled by a rope (3), activates the cutter valve (4)
- While the control lever is held in the unloading position, the cutter cylinder grabs the film band (5) and guides it onto the cutter blade to be cut off between the clamping device and a bale (6)

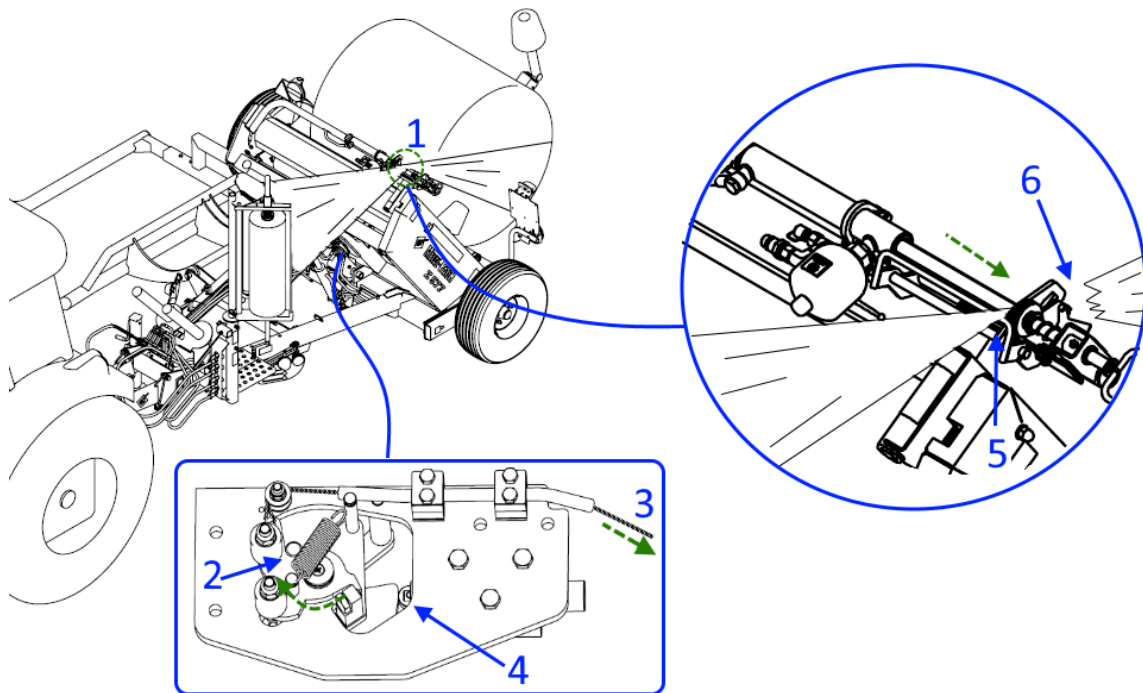

**Figure 59.** Hydraulic cutter – picking and cutting off the film



**CAUTION**

**CAUTION!**

Raising the service table which is not locked in the unloading position risks damage to the cutter unit.

Always lock the service table in the correct position before you start loading or unloading.



Releasing the film after the second revolution of the service table for the hydraulic cutter.

- During the first revolution of the service table, the buffer (Fig. 60 – 1) which is fitted under the service table, sets the lever (Fig. 59 – 2) to the intermediate position after it hits the one of the rollers of the lever (Fig. 60 – 2)
- During the second revolution of the service table, the buffer sets the lever again, but this time to the open position (Fig. 42) after having hit the other roller (Fig. 60 – 3)
- The cutter valve (Fig. 60 – 4) is turned so that it enables the oil from the cutter cylinder to be pushing from the hydraulic manifold to the discharge T line, and the clamping device of the cutter to be opened
- After the valve is turned to the open position of the cutter, the buffer will not hit the lever rollers during subsequent revolutions of the service table

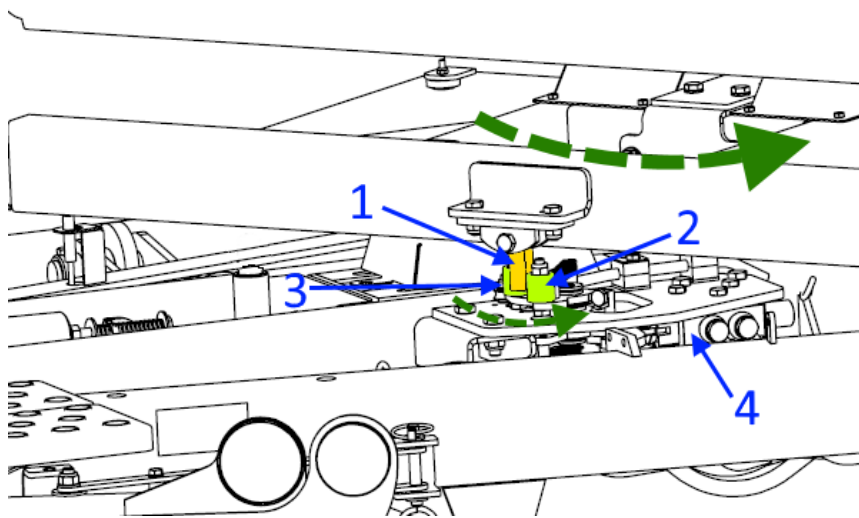

**Figure 60.** Hydraulic cutter – cutter opening mechanism

#### 4.6 Film breaking

Follow the procedure below if the film breaks during wrapping.

- Stop the service table rotary movements smoothly
- Set the lever of the tractor's hydraulic manifold to neutral, switch off the engine of the tractor, apply the auxiliary brake and take the key from the ignition
- Pull the film band from the film feeder and fix its end to a bale
- Start the tractor and its hydraulic system
- Start wrapping and make additional revolutions of the service table to cover the bale tightly, if needed

#### 4.7 End of operation – the Bale Wrapper transporting position

After the work is finished, clean the machine of the hay, net, and film remains. Disconnect the revolution counter and put it away in the tractor cab.

Set the Bale Wrapper in the transporting position.

- Park the tractor with the Bale Wrapper on level and solid ground
- Set the hydraulic cutter in the open position and secure the guard of the hydraulic cutter blade by repositioning it
- Release the lock of the right ground wheel position (Section 3.6.1)
- Set the right ground wheel of the Bale Wrapper to the transporting position (Section 3.6.3) using the hydraulic cylinder, if present (Section 3.7).
- Release the lock of the right wheel position (Section 3.6.2)
- Set the bale tipper to the transporting position and secure it (Section 7.1.1)
- Lift the loading arm to its maximum height and fit the transporting lock (Section. 7.1.2)
- Having disconnected the plug of the hydraulic supply hoses, use plastic caps to secure them (Fig. 61 – 1) and place them in the holders on the machine frame (Fig. 61 – 2)
- Set the front lights of the Bale Wrapper to a position for road the transporting (Section 3.16)

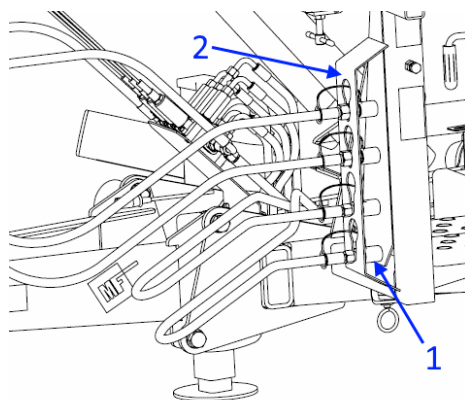

**Figure 61.** Hydraulic hose holder



**CAUTION**

**CAUTION!**

Disconnecting the Bale Wrapper from the tractor with a bale lying on the turntable is not allowed.



**CAUTION**

**CAUTION!**

Driving the Bale Wrapper on public roads with a bale loaded is not allowed.

## 5. Operation and maintenance activities



### WARNING

#### WARNING!

The operation and maintenance activities can be performed exclusively by persons familiar with this Instructions Manual, having the relevant qualifications and tools for performing such activities. Lack of knowledge concerning the principles of safe operation and maintenance works of the Wrapper and the use of improper tools can result in hazard to human life or machine damage.

While performing operation-maintenance works you should wear appropriate protective clothes and boots, adequate for the activities to be performed and substances with which you will be in contact.

Do not repair leakages from the pressurised devices and hydraulic elements.

In the event of damaging machine parts they should be replaced with new, original parts. The use of non-original or incorrect parts results in the loss of the machine guarantee.

Unintended operation of the Wrapper or operation by unauthorised persons who do not have right qualifications must be strictly avoided.

Accidental starting up of the machine must be prevented.

In case it is necessary to carry on work on Wrapper elements which cannot be reached standing on the ground, only equipment intended for ascending (safe ladders) can be used. Do not use Wrapper elements for climbing the machine.



Tighten the bolts on fixed connections according to the values of the tightening torques shown in Table 6 (Section 5.4).

Tighten the bolts on moving connections so that the lowest possible play is achieved and their mobility is preserved.

Follow the check lists during connecting the machine with the tractor, starting it up and disconnecting the Wrapper with the tractor.



It is recommended to run an operation and maintenance activities log book. This will allow a continuous insight into the machine's technical condition and to avoid repair activities in the field.

Hydraulic oil leakages to the environment must be prevented. Carry out repairs to the hydraulic installation in a place where there is no danger of oil penetration into the soil, ground water, food, or animal fodder. Use tight and safe containers to store used oil.

If it is necessary to conduct operation-maintenance activities under elevated machine parts (e.g. wheel replacement), they must be protected against lowering by installing stable supports underneath.

When changing a wheel, lift the Bale Wrapper using the points marked with the jack pictogram.



**CAUTION**

**CAUTION!**

Do not inflate the tyres over the recommended pressures. For unladen machine this is 3.5 bar.

## 5.1 Cleaning



Take great care with the use of pressure devices during the cleaning procedure. The bearings and the bolt, hydraulic and electrical, connections are not water-resistant. Do not expose these components to water for a longer time. Each time after you clean the machine with water, these components must be lubricated again. Dry the places where the electrical bundle sheath is damaged and protect them with water-resistant repair tape for electrical bundles.

### Cleaning the machine after use

- Clean the machine of all vegetation, their residues, and other dirt.
- Clean the lighting components.
- Clean the warning pictograms and the rating plate to keep them legible.
- Wipe the film-adjuster rollers to remove dirt; denatured alcohol can be used for this.
- The service-table rollers can be washed with water with detergent and a pressure device.

### Protecting the machine after cleaning

- After you have cleaned the machine with water, lubricate bearings, gaskets, and articulated connections again.
- Apply a layer of a plant-origin oil on the film-cutter blades.
- Protect any coating defects and protective layer scratches with anti-corrosion agents and paint.
- Damaged safety stickers must be renovated or added as required.

Clean the soiled L-02 counter casing with a damp piece of cloth with some detergent. Do not use organic solvents for washing (e.g. acetone, benzine, nitro solvent), as it can result in damage to the panel casing.

The rating plate to be replaced in the service only.



Take the counter to the authorised service centre if it is damaged. Repairing the counter yourself voids the guarantee.

## 5.2 Machine maintenance



To maintain the proper working order and service life of the moving components of the machine, follow the guidelines laid down in the maintenance table (Tab. 7) and carry out regular inspections of the machine. The maintenance work is to be carried out on the Wrapper set in the working position. If any other position needs to be used, it will be noted accordingly.



Use the greases class EP 2 or EP 3 (e.g. LT-43 EP-3) as plastic grease. Use a grease gun to apply lubrication via the grease nipples. Use a brush covered with grease to lubricate sliding surfaces. As for the roller chains, it is recommended to use greases and oils dedicated for roller chains.

Removing from the sliding surfaces as much of the residue of the previous grease as possible before carrying out the lubrication is recommended, as it can contain contaminations (sand, organic impurities) which can cause quicker part degradation or loss of grease properties. After carrying out the lubrication, remove the excess of grease spilt from the lubrication points so that you prevent them from attracting dirt and hampering the machine's operation.

## 5.3 Scheduled Inspections

Periodic routine inspections are recommended to be performed after each two seasons of machine use. For replacements it is recommended to use original spare parts which will ensure maintaining the Wrapper in full efficiency for a long period of its operation.

Replace the power hydraulics rubber hoses every 5 years.

Follow the procedure below to change the oil in the angle gearbox of the machine every two years.

- Position the machine on level ground
- Place a suitable, watertight, container under the drain plug
- Unscrew the inlet, drain, and overflow plugs
- Once the oil has been drained, replace and tighten the drain plug
- Pour the 80W90 transmission oil through the inlet hole up to the overflow-cap level
- Tighten the overflow and inlet plugs
- Supply the used oil to a petrol station that deals in its purchase.



**CAUTION**

**CAUTION!**

During the operation of the oil exchange use impermeable protective clothes adapted for contact with crude-oil-derived products.

#### 5.4 Metrical-bolt tightening torques

Optimised tightening-torque values for bolts or screws and nuts [Nm] are shown in Tab. 6.

**Table 6.** Tightening-torque values for metric bolts

Bolt-tightening torques – metrical bolts in Nm							
Size Ø mm	Pitch mm	Bolt version – strength classes					Wheel nuts, wheel screws
		4.8	5.8	8.8	10.9	12.9	
3	0.50	0.9	1.1	1.8	2.6	3.0	
4	0.70	1.6	2.0	3.1	4.5	5.3	
5	0.80	3.2	4.0	6.1	8.9	10.4	
6	1.00	5.5	6.8	10.4	15.3	17.9	
7	1.00	9.3	11.5	17.2	25	30	
8	1.25	13.6	16.8	25	37	44	
8	1.00	14.5	18	27	40	47	
10	1.50	26.6	33	50	73	86	45
10	1.25	28	35	53	78	91	
12	1.75	46	56	86	127	148	
12	1.50						80
12	1.25	50	62	95	139	163	
14	2.00	73	90	137	201	235	
14	1.50	79	96	150	220	257	140
16	2.00	113	141	214	314	369	
16	1.50	121	150	229	336	393	220
18	2.50	157	194	306	435	509	
18	1.50	178	220	345	491	575	300
20	2.50	222	275	432	615	719	
20	1.50	248	307	482	687	804	400
22	2.50	305	376	502	843	987	
22	2.00						450
22	1.50	337	416	654	932	1090	500
24	3.00	383	474	744	1080	1240	
24	2.00	420	519	814	1160	1360	
24	1.50						550
27	3.00	568	703	100	1570	1840	
27	2.00	615	760	1200	1700	1990	
30	3.50	772	995	1500	2130	2500	
30	2.00	850	1060	1670	2370	2380	

## 5.5 Lubrication interval

**Table 7.** Lubrication-interval table

COMPONENT NAME	LUBRICATION POINT	FIGURE NO.	LUBRICATION INTERVAL				NOTES
			Every 10 working hours	Every 50 working hours	Pre-seasonally	Post-seasonally	
Turntable bearings	5	63			•		Grease gun – bearing lubricant
Service-table roller bearings	5	62		•	•	•	Bearing lubricant or lube oil
Film-feeder bearings	5	62		•	•	•	Bearing lubricant or lube oil
Articulation pins of moving parts	2	62, 63		•	•	•	Grease gun – bearing lubricant
Chain drive – service table, roller drive, film-tensioner gear unit	3	62, 63	•		•	•	Oils or grease dedicated for roller chains
Film-roll-clamping-device thread	7	62		•		•	Bearing lubricant or lube oil
Support-foot device thread	7	62			•	•	Grease gun – bearing lubricant
Cylinder bushes	6	62, 63		•	•		Grease gun – bearing lubricant
Film cutter device – revolution axle	8	62, 63		•	•		Grease gun – bearing lubricant
Film cutter device – moving articulation	8	62, 63	•		•		Bearing lubricant or lube oil
Film cutter device – cutting blades	1	62				•	Plant-based oil
Axle gear box (mechanical cutter)	4	62	Refill gearbox oil every 2 years				80W90 gear oil
Axle gear box (hydraulic cutter)	4	62			•		Bearing lubricant

## 5.6 Lubrication points

List of parts to be lubricated (Fig. 62, 63)

- 1 – Film cutter blade
- 2 – Pin
- 3 – Chain drive
- 4 – Axle gear box
- 5 – Rolling bearing
- 6 – Cylinder bushes
- 7 – Thread
- 8 – Film cutter unit

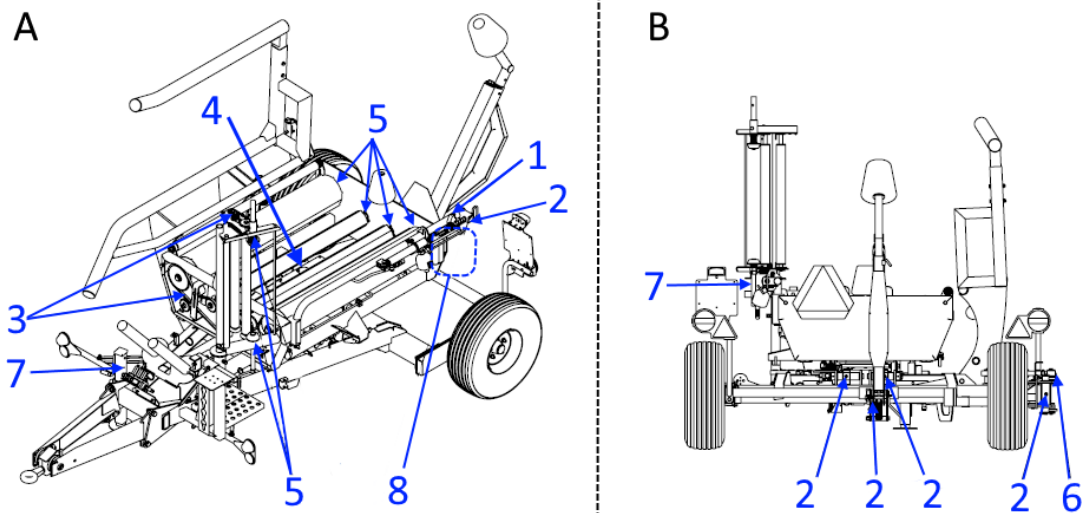

**Figure 62.** Lubrication points A – diagonal view, B – back view

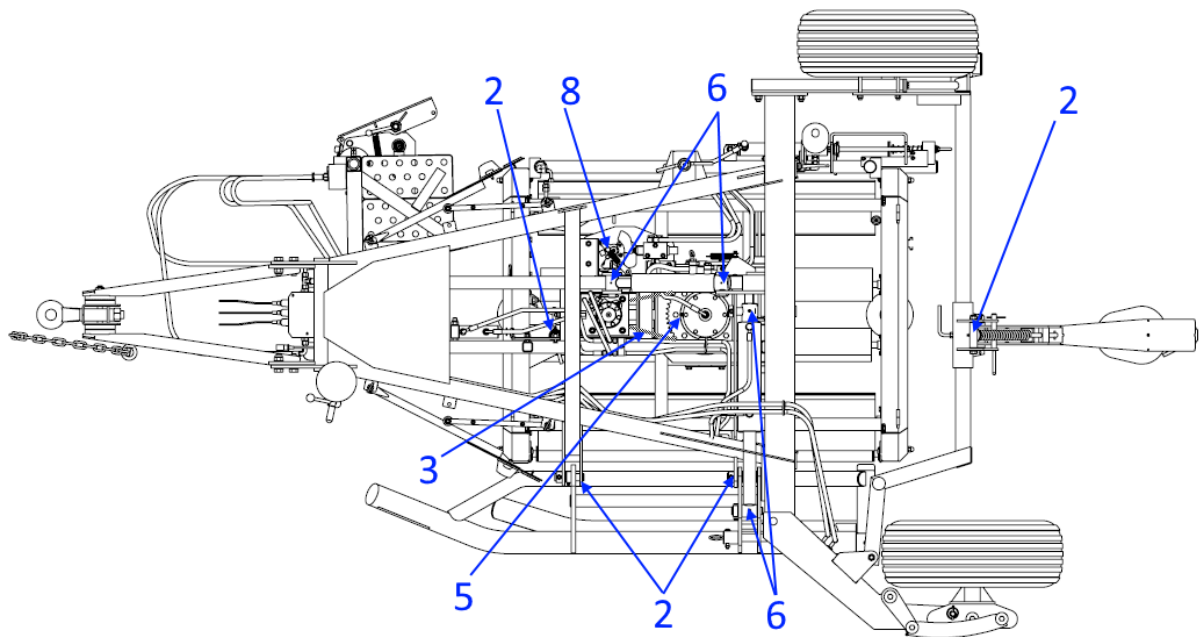

**Figure 63.** Lubrication points – bottom view



## **6. Authorised service**

### **6.1 Guarantee service**

The manufacturer provides a guarantee for the machine on the terms and conditions stipulated in the Guarantee Certificate. In the period covered with the guarantee the repairs are performed by the authorised services of the dealers or the manufacturer's services.

### **6.2 Routine service**

After the period of the guarantee coverage it is recommended to have carried out periodic inspections at the authorised services of the dealers.

### **6.3 Ordering spare parts**

Purchase the spare parts at the dealer centres, or order them from the manufacturer directly, providing first and last name, or the company name and the address of the buyer, name, logo, factory number and year of manufacture, catalogue-part name, catalogue drawing or standard number, number of ordered parts, and agreed terms of payment.

## 7. Wrapper transporting

### 7.1 Road-Traffic Participant

The Bale Wrapper is designed for public-road traffic as a machine attached to the farm tractor's hitch

The dimensions of a machine properly prepared for transporting – Section 1.6.

Only agricultural tractors with a power output not lower than 30 kW and a drawbar-pull class not lower than 0.9, fitted with the farm hitch, can be used for transporting on public roads. The tractor with the Bale Wrapper coupled with it must meet the stability requirements – Section 7.2.

Prior to entering the public roads prepare the Bale Wrapper properly.

- Lock the rotary frame of the machine (Section 4.5.3, Fig. 57).
- Secure the bale-tipper unit to the transporting position (Section 7.1.1)
- Lift the loading arm and fit its transporting-lock (Section. 7.1.2)
- Set the right ground wheel to the transporting position and secure it (Section 3.6)
- Set the front lights of the Bale Wrapper to the transporting position (Section 3.16)
- Disconnect and protect the hydraulic hoses properly (Section 4.7, Fig. 61)
- The control levers can be left in the cab or fixed to the holder over the hydraulic manifold.
- Remove the film roll from the feeder and place it in the storage bin in the front section of the frame
- If required by the local regulations, connect the machine's lighting plug and use a bracket to fit the Bale Wrapper with a board for slow-moving vehicles



**CAUTION**

**CAUTION!**

Prior to each departure of the Bale Wrapper onto public roads, check the correctness of the machine's connection with the tractor



**CAUTION**

**CAUTION!**

Before you drive on public roads, remove the film roll from the feeder and put it inside the storage bin on the Bale Wrapper's drawbar.



**CAUTION**

**CAUTION!**

It is forbidden to carry people or silage bales on the turntable or other components of the Bale Wrapper.



**CAUTION**

**CAUTION!**

When transporting the machine on public roads, adjust the speed to the traffic conditions and do not exceed the speed limit given on the Bale Wrapper's tyres (Tab. 2 Section 1.5).

When transporting the Bale Wrapper on public roads follow the Traffic-Law regulations.

If stopping the tractor with an attached Bale Wrapper in an emergency on a public road, the driver must

- stop the vehicle without endangering road safety
- park the vehicle parallel to the road-centre line, as close to the edge as possible
- switch off the engine and remove the key from the ignition, engage the auxiliary brake, and place chocks under the wheels of the Bale Wrapper
- switch on the hazard lights and place a warning triangle between 30 and 50 metres behind the vehicle, outside a built-up area
- outside a built-up area, switch on the hazard lights and place a warning reflective triangle behind the vehicle, unless it is installed in a bracket at the rear of the machine, but always ensure that other road users can see it clearly
- in the event of a breakdown, take the appropriate steps to ensure safety for yourself and other road users

### 7.1.1 The Bale tipper's transporting position

Follow the procedure below to set the bale tipper to the transporting position (Fig. 64).

- Push the arm of the bale tipper (1) towards the Bale Wrapper
- Engage the pin which locks the tipper in its transporting position (2)
- The tipper arm should rest on the pin after lowering
- Use the locking pin to secure the position (3)

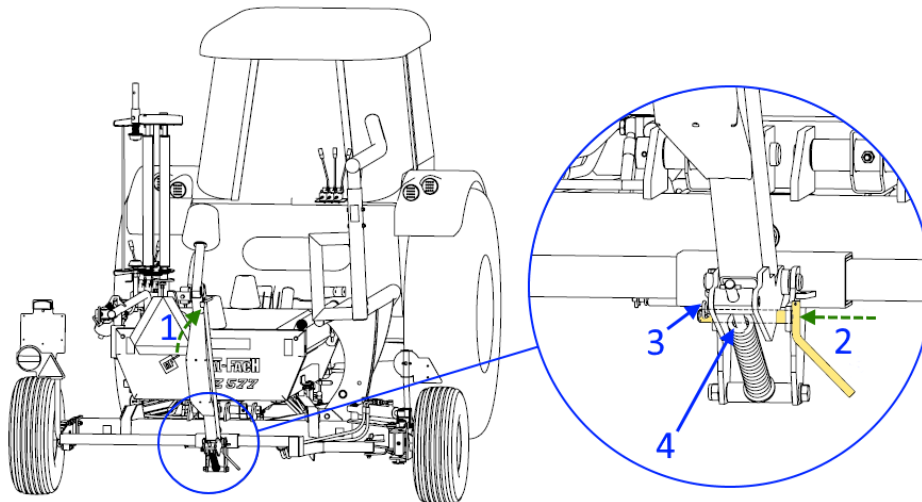

**Figure 64.** Locking the bale tipper in the transporting position

### 7.1.2 Securing the loading arm

Follow the procedure below to secure the loading arm in the transporting position (Fig. 47).

- Set the service table in the locked position and ready for loading, i.e. in parallel to the longitudinal centre line of the machine
- Use the control lever to lift the loading arm to its maximum height
- Switch off the engine of the tractor, apply the auxiliary brake, and take the key from the ignition
- Remove the locking pin (1) from the retaining pin of the arm for transporting (2)
- Move the retaining pin in the bushes to the hole which is closest to the pin's eye
- Insert the locking pin through the pin eye to secure it in place

## 7.2 The Tractor's and Bale-Wrappers stability

Before coupling the tractor with the Wrapper, make sure that the traffic is fully manoeuvrable. The front-axle load of the tractor must be at least 20% of the tractor's weight (Fig. 65). If this condition is not fulfilled the front axle of the tractor must be loaded additionally.

Never couple the Bale Wrapper with a tractor which fails to meet the stability requirement.

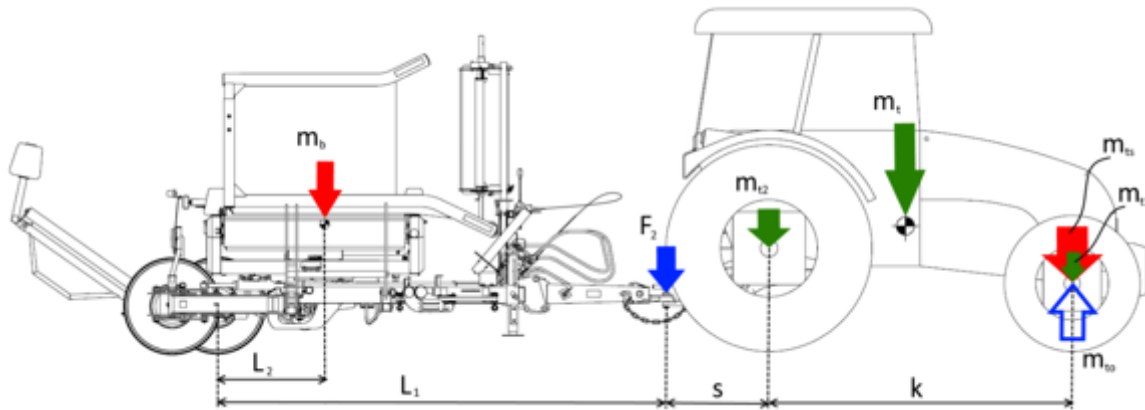

**Figure 65.** The Tractor's and Bale-Wrappers manoeuvrability

Calculating the manoeuvrability of the Tractor and Bale Wrapper (Fig. 65).

$$F_2 = \frac{m_b \times g \times L_2}{L_1} \Rightarrow |F_2| \approx 4200 \text{ N}$$

$$m_{to} = \frac{F_2 \times (k + s)}{k \times g}$$

$$m_{ts} = m_{t1} - m_{to}$$

$$m_{ts} \geq 0,2 \times m_t$$

Where

$F_2$  – downward vertical force acting on the hitch [N]

$m_b$  – maximum Bale-Wrapper weight [kg]

$m_t$  – tractor weight [kg]

$m_{t1}$  – the front-axle load of the tractor, without the Bale Wrapper's being hitched [kg]

$m_{to}$  – the additional unloading of the tractor's front axle after coupling the Bale Wrapper [kg]

$m_{ts}$  – the front-axle load of the tractor with the Bale Wrapper hitched [kg]

$g$  – gravitational acceleration,  $g=9.8$  [m/s<sup>2</sup>]

$L_1$  – the distance from the hitch point to the Bale Wrapper's wheel-centre line,  $L_1=4.1$ [m]

$L_2$  – the distance from the Bale Wrapper's weight centre to its wheel-centre line,  $L_2=0.57$ [m]

$k$  – the distance between the tractor's axles [m]

$s$  – the distance between the centre of the rear axle of the tractor to the hitch point [m]

### 7.3 Load transporting

The Wrapper is adapted for the rail and road transporting of the appropriate capacity.

When loading, ensure the Bale Wrapper is in its transporting position and all the moving parts have their locks enabled.



**CAUTION**

#### CAUTION!

For loading onto road vehicles, use lifting equipment with a lifting capacity appropriate for the Bale Wrapper's weight, including with a film roll loaded. As lifting points, use the parts of the frame marked on the machine with a pictogram .

The suspension sling attachment points are shown in Fig. 58.

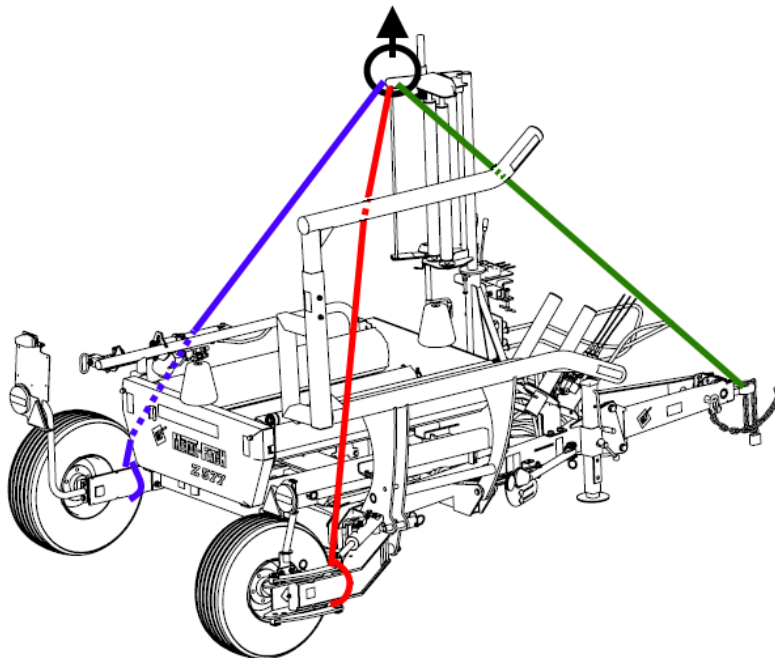

**Figure 66.** The suspension-sling attachment points on the Bale Wrapper

Lifting equipment can be operated by trained operators holding the relevant qualifications. It is forbidden to transport the Bale Wrapper with a bale located on it. During the time of the transporting the transported Wrapper should be permanently and reliably attached to the floor.

## 8. Wrapper storage

Post-seasonally, or after a longer period of the Bale Wrapper's non-use, perform the following tasks.

- Remove the film rolls from the feeder
- Clean the machine (Section 5.1)
- Carry out the recommended maintenance works (Section 5.2)
- Repair or replace parts if damaged
- Set the machine on a level, compacted, surface and place chocks under the Wrapper's wheels to prevent the Wrapper from rolling away
- It is recommended to store the Bale Wrapper under roofing or a protective waterproof tarpaulin
- Storing the Bale Wrapper in its transporting position with the loading arm secured against dropping is recommended
- Store the Bale Wrapper in a manner which does not compromise the safety of persons or animals The film cutter fitted with sharp blades must remain in the closed position
- Ensure the good condition and legibility of the rating plate If damaged, contact the service centre
- Store the wrap counter in a dry room protecting the terminals against dirt and humidity
- Secure the machine against unauthorised use (Fig. 10 – 1).



**CAUTION**

**CAUTION!**

Store the Wrapper in the atmosphere free from aggressive factors (e.g. ammonia, chemicals).

## 9. Residual Risk

### 9.1 Residual-risk descriptions

Residual risk results from an erroneous behaviour of the Bale Wrapper's operator. The following prohibited actions cause the highest level of risk.

- Assembly of the Bale Wrappers on tractors which do not fulfil the requirements described in the Instructions Manual
- Standing under raised machine units
- Persons standing in the area of Bale Wrapper operation
- Servicing or repairing the Bale Wrapper when the tractor engine is still on
- Using faulty hydraulic lines
- Control of the Bale Wrapper by an operator who is outside the tractor cab
- Operating the Bale Wrapper under the influence of alcohol
- Operating a damaged Bale Wrapper or operation with the guards removed
- Operating the Bale Wrapper on slopes exceeding 8°
- Transporting silage bales on the Bale Wrapper
- Persons standing on the machine during its operation or the transporting
- Failing to use the Bale Wrapper for its intended purpose
- Leaving the unsecured Bale Wrapper on slopes
- Entering the area between the tractor and the machine when the engine is running

The presentation of residual risk it is assumed that the Bale Wrapper is a machine which until the moment of starting up had been designed and made according to the current state of the art.

### 9.2 The Assessment of Residual Risk

By observing the recommendations such as

- read the guidelines of the Instructions Manual carefully and adhere to them
- standing under raised machine units is forbidden,
- no persons allowed in the area of Bale Wrapper operation
- maintenance and repair of the Bale Wrapper at authorised service centres
- operation of the machine by trained and authorised operators
- Protect the Bale Wrapper against access by children and third persons

It is possible to eliminate residual risk associated with the Bale Wrapper operation, and thus the machine can be operated without any risk to humans and the environment.



**WARNING**

**WARNING!**

Failure to comply with the instructions and guidance of the Manufacturer can result in residual risks.



## 10. Wrapper disposal

Disassembly and disposal should be performed by specialized services familiar with the construction and operation of the Wrapper. Only specialised service centres have the full and up-to-date knowledge of the applied materials and the risks associated with the hazards of improper storage and transporting. The authorized services provide both counselling and performance of the complete services concerning the disposal of the machine.

The correct tools and auxiliary equipment (hoist, lifting jack, wheel puller) must be used for disassembly.



**CAUTION**

**CAUTION!**

Store the used oil in airtight containers. Take it to a petrol station which accepts used oil immediately.



**CAUTION**

**CAUTION!**

Disassemble the machine. Sort the disassembled parts. Supply the dismantled parts to the relevant recycling points.



During the disassembly of the Wrapper wear the proper protective clothes and protective boots.

## 11. Typical faults and troubleshooting

The majority of errors and faults can be rectified by the users on their own. Before contacting the service centre or manufacturer, users should check that it is possible to identify and solve the problem by themselves, using the information provided in this Section.

After an error or fault occurs, switch the Wrapper and tractor off and protect them from accidentally rolling away. It is prohibited to operate a damaged machine, as it can lead to the damage in the machine and serious injuries.

**Table 8.** Typical defects which can occur during the use of the Bale Wrapper

No.	Fault description	Cause	Method of rectification
1.	Hydraulic oil gets overheated quickly	Insufficient amount of oil in the tractor's system	Check the oil level in the tractor, and refill if necessary
		The volume consumption on the tractor valve is set incorrectly	Reduce the oil consumption volume in the tractor
		Supply pressure too high	Set a lower supply pressure
		Power hydraulic plugs connected incorrectly	Check the correct connection and condition of the hydraulic plugs
2.	Hydraulic cylinders move too slowly	Insufficient amount of oil in the tractor's system	Check the oil level in the tractor and refill if necessary.
		The volume consumption on the tractor valve is set incorrectly	Reduce the oil consumption volume in the tractor
		Faulty setting of the cylinder throttling valves	Check the setting of the throttling valves (Section 3.13)
		Power hydraulic plugs connected incorrectly	Check the correct connection and condition of the hydraulic plugs
3.	The hydraulic motor and cylinders work too fast and too hard	Too-high pressure in the hydraulic system	Set a lower supply pressure in the tractor
		Too-high volume of oil consumption from the tractor	Reduce the oil consumption volume in the tractor
		Incorrect manner of Bale-Wrapper control	Follow the recommended method of lever control
4.	One of the cylinders does not move	The system supplying the engine not tight	Check for possible external leakage
		Damaged cylinder	Contact the dealer
		The rod of the control wire damaged	Contact the dealer
No.	Fault description	Cause	Method of rectification
5.	The loading arm cannot lift a bale	Bale weight too high	Try to wrap bales with a weight which meets the use requirements

		The hydraulic system pressure too low	Raise the pressure of the hydraulic supply for max. 160 bar
6.	The service table tends to rotate when loading	The service table not locked after being stopped	Remember to lock the table before it moves to the unloading position
		The throttle/ non-return valve at the hydraulic manifold not adjusted	Adjust the throttle/non-return valve at the hydraulic manifold (Section 3.13.1)
7.	Bales positioned incorrectly when lowered onto the bale tipper	The bale tipper position set incorrectly	Adjust the bale tipper position (Section 3.8)
		Bales are too heavy or deformed	Try to wrap bales with a weight which meets the use requirements
			Exercise caution when wrapping bales of a low compaction degree
		Terrain slope too high	Unload bales on a level ground
8.	Film is not picked up	The film-clamping mechanism set incorrectly	Set the film-clamping mechanism (Section 3.14)
		The film-feeder setting incorrect	Set the height and angle of the film feeder
9.	Film is not cut	The film-cutting mechanism set incorrectly	Set the film-cutting mechanism (Section 3.14)
		The blade fixed loosely; worn blade	Fix the blade properly; replace the blades
10.	Problems with bale loading, wrapping, and unloading	Unsuitable shape or/and dimensions of the bale	Wrap bales with the correct shape and dimensions given in the Bale Wrapper characteristics
11.	The film on a wrapped bale is damaged during unloading	Incorrect place of unloading	Unload the wrapped bales only at a place which does not pose a risk of damaging the bale
		Bale's tipper position incorrect	Set the bale tipper closer to the right axle shaft
		Incorrect procedure during unloading	Lock the service table prior to unloading
No.	Fault description	Cause	Method of rectification
12.	Improper film coverage of a bale	Too-few layers	Set a correct, efficient, number of turntable revolutions for bale wrapping
		Incorrect ratio of turntable-roller revolutions to turntable revolutions	Check that a correct double sprocket is fitted for the film width (Section 3.12.1)

		The film-feeder setting incorrect	Set the correct height of the film feeder, release the frame hook in which a film roll is mounted
13.	Damage and breakage of the film band during wrapping	Damaged surface of the adjuster roller	Rub the roller surface with sandpaper
			Replace heavily damaged tensioner rollers with new ones
		Contaminated surface of the adjuster roller	Clean the roller surface
		Damaged film roll	Use better-quality film which meets the elongation requirement to replace the film roll
			Exercise caution when mounting a roll onto the feeder
Tension of the drive chain of the film tensioner too high	Reduce the tension of the drive chain of the film tensioner		
14.	The bale counter does not count revolutions	Distance between the sensor and activating magnet incorrect	Set the correct distance between the sensor and activating magnet
		Sensor wire or plug connecting the sensor with the counter damaged	Check the condition of the sensor wire and plug, contact the distributor
15.	Occasional hindrance when unlocking the retaining pin which secures the right ground wheel in place	The retaining pin is hindered by the axle shaft of the ground wheel	Push the ground wheel away from the side toward the lock and remove the pin

## 12. Accessories

The user can purchase the following optional and additional equipment additionally at the dealer or at the manufacturer

- Ground-wheel hydraulic shifting set (Section 3.7)
- Spare parts catalogue – hard copy
- A triangular plate indicating slow-moving vehicles,
- Extractor for sprockets of the roller-drive chains
- Varnish-coating repair set.

## INDEX OF NAMES AND ABBREVIATIONS

A – Ampere, electric-current unit

Bar – bar, pressure unit (1 bar = 0.1 MPa)

OS&H – occupational health and safety

dB (A) – decibel A, sound-pressure unit

Drawbar pull class – a value characteristic for the drawbar pull of a tractor, class 0.9 corresponds to a drawbar pull of 9 Kn. The Ursus C 355 and 4011 tractors have this pull class.

kg – kilogram, weight unit

km/h – kilometre per hour, linear-speed unit

kW – kilowatt, power unit

m – metre, length unit

mm – millimetre, an auxiliary length unit equal to 0.001m

min – minute, an additional time unit corresponding to 60 seconds

rev. – revolution, a type of movement

rpm – revolutions per minute, rotation speed unit

Pictogram – a notice plate

Fig. X – a figure with a number “X”

Fig. X, Y – figures with numbers “X” and “Y”

Fig. X-Y – a figure with a number “X”, item in the figure “Y”

Tab. X – a table with a number “X”

Rating plate – a manufacturer’s plate unambiguously identifying the machine

UV – ultraviolet radiation, invisible electromagnetic, invisible electromagnetic radiation with negative effects on human health; UV radiation has a negative effect on rubber parts

V – Volt, a voltage unit

Hitch, upper the transporting hitch – hitch components of a farming tractor (see a tractor instructions manual)

## ALPHABETICAL INDEX

### PART I

#### B

Bale tipper 47

#### C

Chain 49-51

Control lever 39

Control panel 39

#### D

Design, Bale Wrapper 15

#### F

Film cutter 55-59

Film feeder 40

G 43-46

Ground wheel

#### H

Hazard-warning symbols 20-22

Hydraulic system 33-34

#### I

Identification, Bale Wrapper 11

Intended use, Bale Wrapper 14

#### L

Lighting 32, 60

Loading arm 48

#### O

Oil 34, 53, 59

#### P

Pictograms 19

#### R

Rating plate 11

#### S

Safety principles 23

Start-up 35

#### T

Technical characteristics 16-17

#### W

Wrapping 14, 52

## **PART II**

### **A**

Accessories 46

### **B**

Bale loading 17

Bale unloading 20

### **C**

Cleaning 28

### **D**

Disassembly 42

### **F**

Film clamping 8

Faults 43-45

Film cutting 22-24

### **L**

Lubrication 30, 32

Lubrication points 33

### **M**

Maintenance 30

### **O**

Oil 30

### **R**

Risk 41

Road traffic 35-39

### **S**

Scheduled Inspections 30

Servicing 34

Storage 40

### **T**

The transporting 35

The transporting position 26

### **W**

Wrap Counter 9-12

Wrapping 18



## NOTES

A series of horizontal dotted lines for taking notes, spanning the width of the page.

A series of horizontal dotted lines for notes or a checklist, consisting of 24 rows of evenly spaced dots.

A series of 25 horizontal dotted lines spanning the width of the page, providing a template for handwritten notes or a checklist.

A series of horizontal dotted lines for writing, spanning the width of the page.

A series of horizontal dotted lines spanning the width of the page, providing a template for handwritten notes or a checklist.





Since Metal-Fach Sp. z o.o. is continuously improving its products, and adapting its product range to fit the customers' needs, we reserve the right to modify our products without prior notice. Therefore, we advise contacting an authorised dealer or sales representative of Metal-Fach Sp. z o.o., prior to making your decision about purchase.

Metal-Fach Sp. z o.o. will not accept any complaints regarding the data and pictures contained in the catalogue, as the presented range of products does not constitute an offer within the meaning of the provisions of the Civil Code.

The pictures do not necessarily show standard accessories.

Original spare parts are available from authorised dealers, both in Poland and abroad, and also at the Metal-Fach retail outlet.



#### TECHNICAL SERVICE

16-100 Sokółka, ul. Kresowa 62  
Tel.: +48 85 711 07 80; Fax: +48 85 711 07 93  
serwis@metalfach.com.pl

#### SALES

16-100 Sokółka, ul. Kresowa 62  
Tel.: +48 85 711 07 78; Fax: +48 85 711 07 89  
handel@metalfach.com.pl

#### SPARE PARTS WHOLESALE STORE

16-100 Sokółka, ul. Kresowa 62

##### Wholesale:

Tel.: +48 85 711 07 81; Fax: +48 85 711 07 93  
serwis@metalfach.com.pl

##### Retail

24/7 PHONE: +48 533 111 477  
Tel.: +48 85 711 07 90

CURRENT INFORMATION ON OUR PRODUCTS CAN BE FOUND ON [WWW.METALFACH.COM.PL](http://WWW.METALFACH.COM.PL)