



**METAL-FACH**



## **MANURE SPREADER**

### **“BATALION”**

**N280, N280/1, N280/2**

**INSTRUCTION MANUAL**

**TRANSLATION OF THE ORIGINAL INSTRUCTION MANUAL**

**REVISION I**

**FEBRUARY 2019**



## EC DECLARATION OF CONFORMITY

The undersigned:	Jacek Kucharewicz, President of the Board	
hereby declares with full responsibility that the complete machine:		
<b>"Hornet"</b>		
1.1.	Brand (trade name of the manufacturer)	Metal-Fach
1.2.	Type:	N280; N280/1; N280/2
1.2.1.	Variant:	-
1.2.2.	Version:	-
1.2.3.	Trade name(s) (if any):	Manure Spreader
1.3.	Category, Subcategory and Vehicle Speed Indicator:	R
1.4.	Company name and address of the Manufacturer:	Metal-Fach sp. z o.o. ul. Kresowa 62 16-100 Sokółka, Poland
1.4.2.	Name and address of an authorised representative of the Manufacturer (if applicable):	N/A
1.5.1.	Location of the rating plate of the Manufacturer:	On the front beam of the hopper
1.5.2.	The method used to fix the rating plate of the Manufacturer:	Riveted, glued
1.6.1.	Location of the vehicle identification number on the chassis	On the front beam of the hopper
2.	Machine identification number:	
<p>complies with all the relevant regulations of Directive 2006/42/EC and Regulation of the Minister of the Economy dated 21st October 2008 on the principal requirements for machines (Journal of Laws of 2008, No. 199, item 1228, as amended)</p> <p>The following harmonized standards were applied to assess compliance:  <u>PN-EN 690:2014-02, PN-EN ISO 12100:2012, PN-EN ISO 4254-1:2016-02,</u>  <u>PN-EN ISO 13857:2010</u></p> <p>and the following standards: PN-ISO 3600:2015, PN-ISO 11684:1998 and Regulation of the Minister of Infrastructure dated 31st December 2002 on technical conditions of vehicles and the range of their essential equipment (Journal of Laws of 2003, No. 32, item 262, as amended).</p> <p style="text-align: center;"><b>Safety Testing Report No.: LBC/11/12</b></p> <p style="text-align: center;"><b>This EC Declaration of Conformity shall become null and void, if the machine is modified or reconstructed without the Manufacturer's consent.</b></p>		

Sokółka  
(Location)

05/01/2017  
(Date)

**Jacek Kucharewicz**  
(Signature)

**President of the Board**  
(Position)

## Machine data

<b>Type of machine:</b>	Manure Spreader
Type designation:	N280, N280/1, N280/2*
Serial Number <sup>(1)</sup> :	_____
Machine Manufacturer:	METAL-FACH Sp. z o.o. 16-100 Sokółka ul. Kresowa 62 Tel.: (0-85) 711 98 40 Fax: (0-85) 711 90 65
Seller:	_____
Address:	_____ _____
Phone/Fax:	_____ _____
Delivery date:	_____
<b>Owner</b> or <b>User:</b>	Name: _____
Address:	_____ _____
Phone/Fax:	_____

\*Delete as applicable

\_\_\_\_\_  
<sup>(1)</sup>The data is located on the machine's rating plate located on the front part of the machine's main frame

## Table of Contents

INTRODUCTION .....	7
1. Basic Information .....	9
1.1 Introduction .....	9
1.2 Identification of Manure Spreaders N280, N280/1, and N280/2 .....	9
1.3 The intended use of the Manure Spreader .....	10
1.4 Basic accessories .....	12
1.5 Transport.....	12
1.6 Environmental hazards .....	14
1.7 Withdrawal from use .....	15
2. Safety of use.....	16
2.1 Basic safety principles.....	16
2.1.1 Obligation to provide information .....	16
2.1.2 General safety and use regulations .....	16
2.1.3 Safety of operation .....	16
2.1.4 Working with the machine .....	19
2.1.5 Pneumatic and hydraulic systems.....	20
2.1.6 Working with the PTO shaft .....	21
2.2 Residual Risk .....	22
2.2.1 Information about Residual Risk .....	22
2.2.2 The Assessment of Residual Risk .....	22
2.3 Warning and information stickers.....	23
3. The Design and Principles of Operation .....	28
3.1 Basic Technical Data .....	28
3.2 The Design and Principles of Operation .....	31
3.2.1 The feeding mechanism.....	32
3.2.2 The drive unit of the adapter .....	33
3.2.3 The 4-rotor vertical spreading adapter .....	33
3.2.4 Adapter cover.....	34
3.2.5 Slide gate of the hopper .....	34
3.2.6 The main braking system .....	34
3.2.7 Parking brake .....	38
3.2.8 The electrical and lighting systems .....	39
4. Instructions for Use.....	42
4.1 Preparing the Machine for Operation .....	42

4.1.1	Checking the Spreader after Delivery .....	42
4.1.2	Preparing the Spreader for the initial start-up .....	42
4.1.3	Changing the Position of the Hitch .....	43
4.1.4	Initial start-up.....	44
4.2	Coupling and Decoupling of the Spreader .....	45
4.3	Loading the hopper .....	48
4.3.1	Loading and Spreading of Lime .....	49
4.4	Adjusting Fertiliser Doses and Manure Spreading .....	49
4.4.1	Adjusting Fertiliser Doses .....	49
4.4.2	Spreading of manure.....	51
4.4.3	Clogging the Spreading Adapter .....	53
5.	Technical Maintenance.....	54
5.1	Checking and Adjusting the Tension of the Floor Conveyor Chains.....	54
5.2	Maintaining the Hydraulic System .....	55
5.3	Gear maintenance.....	56
5.4	Lubrication.....	58
5.5	Maintaining the Pneumatic System.....	61
5.5.1	Checking the air-tightness and visual inspection of the pneumatic braking system.....	61
5.5.2	Cleaning air filters .....	62
5.5.3	Draining the air tank.....	63
5.5.4	Changing the flexible connection conduits.....	64
5.5.5	Cleaning and maintaining the connections of pneumatic conduits.....	64
5.6	Maintaining the driving axle and brakes.....	64
5.6.1	Maintaining the driving axle.....	64
5.6.2	Maintaining the brakes .....	65
5.6.3	Tyre Maintenance, Disassembly of the Wheels .....	68
5.7	Maintaining the Electrical System and Warning Symbols .....	70
5.8	Cleaning, Maintenance, and Storage.....	71
5.9	Tightening torques of screw connections.....	73
5.10	Defects and Methods of Elimination.....	74
	INDEX OF NAMES AND ABBREVIATIONS .....	75
	ALPHABETICAL INDEX.....	76
	NOTES .....	78

## INTRODUCTION

The information included in the Instruction Manual is valid as on the date of its drawing up. The Manufacturer reserves its right to make design changes to machines, which can result in some values or illustrations not corresponding to the actual state of the machine supplied to the User. The Manufacturer reserves their right to make design changes without any modifications to this instruction manual. The Instruction Manual is part of the basic equipment of the machine. The User is obliged to read the contents of this instruction manual and comply with the recommendations included in it, before using the machine. It will ensure safe use and trouble-free machine operation.

The machine has been built in compliance with the standards in force and the current legal provisions. This instruction manual describes the basic safety and operation principles of the Manure Spreader made by Metal-Fach, type N280, N280/1, and N280/2.

The significant obligations of the Manufacturer are shown in the guarantee card, which includes the complete regulations currently in force regarding guarantee services.

Should the information included in the instruction manual be incomprehensible, contact the point of sale where the machine was purchased, or the Manufacturer directly for assistance.

The spare parts catalogue constitutes a separate list and is attached in the form of a CD, when the machine is purchased. It is also available on the Manufacturer's website: [www.metalfach.com.pl](http://www.metalfach.com.pl).

According to the Act of 4th February 1994 on copyrights and related Laws (Journal of Laws of 2017, item 880), this Instruction Manual is protected by copyright. It is prohibited to copy and distribute its contents and figures without the consent of the proprietor of the copyright.

The guarantee card and the warranty terms are attached to this Instruction Manual as a separate document.

### **Address of the Manufacturer:**

Metal-Fach sp. z o.o.  
ul. Kresowa 62  
16-100 Sokółka

### **Contact number:**

Tel.: (0-85) 711 98 40  
Fax: (0-85) 711 90 65

## The symbols used in the Instruction Manual:



**DANGER**

Hazard warning symbol. Indicates the occurrence of a serious hazard condition, which can result in death or serious injury, if not avoided. This symbol warns against the most dangerous situations.



**CAUTION**

The symbol indicating particularly important information and recommendations. Ignoring the provided recommendations may result in serious damage to the machine by incorrect operation.



**WARNING**

The symbol indicating the possibility of a hazard occurring, which can result in death or a serious injury, if not avoided. This symbol means that the risk of injury is reduced, compared to the symbol corresponding to the word "DANGER".



This symbol indicates useful information.



This symbol indicates maintenance activities which should be performed periodically.



# 1. Basic Information

## 1.1 Introduction

### THIS INSTRUCTION MANUAL IS PART OF THE BASIC ACCESSORIES OF THE MANURE SPREADER

The machine can only be operated by persons, who have read this Instructions Manual who are familiar with the design and functioning of the Manure Spreader, and with the operation of the tractor unit it works with.

To operate the machine in a safe manner, read and adhere to all the instructions set forth in this Instruction Manual. Abiding by the guidelines provided in the Instruction Manual ensures safe operation for the User and also prolongs the service life of the machine.

## 1.2 Identification of Manure Spreaders N280, N280/1, and N280/2

The Manure Spreader should be identified by referring to the nameplate, which is permanently attached to the front beam of the hopper.

The data printed on the rating plate of the Manure Spreader is shown in Figure 1.

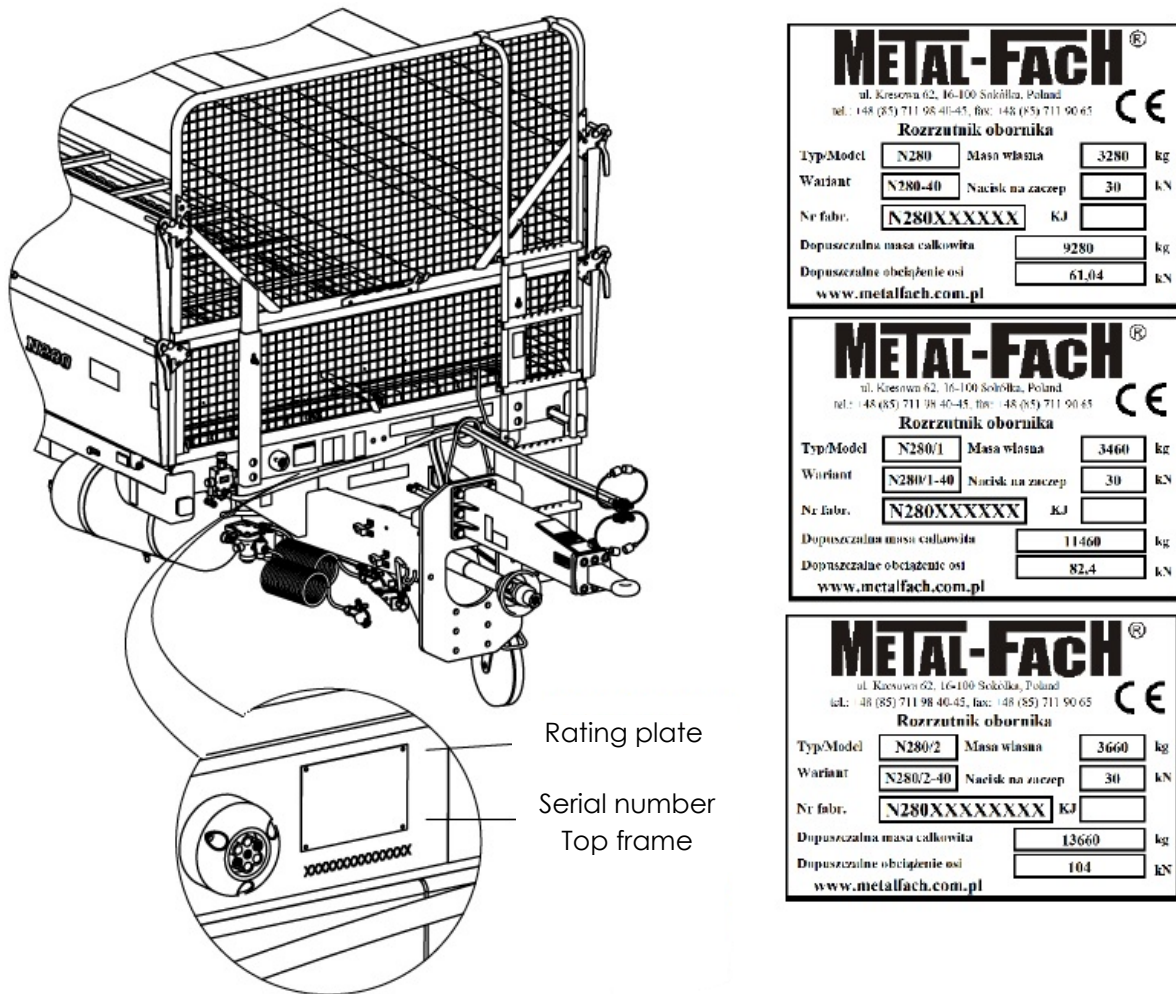

Figure 1 The position of the rating plate and serial number



CAUTION

**CAUTION!**

It is prohibited to enter public roads, if the Manure Spreader has no rating plate or it is illegible.



When purchasing, make sure that the factory number printed on the machine's rating plate and the number provided in the Instruction Manual and Guarantee Card are the same - it is crucial for recognising the guarantee. When contacting the technical service, the seller, or the Manufacturer, the User is obliged to provide the information included on the machine's rating plate.



The Instruction Manual is part of the basic accessories of every Manure Spreader.

Should the Spreader be sold to a different User, it is obligatory to hand the Instruction Manual to them. It is recommended that the supplier of the Spreader to keep a record of every confirmation of receipt signed by the purchaser, when the Instruction Manual is submitted with the machine to the new User.

**Please read the Instruction Manual carefully!**

If you follow its recommendations, it will be possible to avoid hazards, operate the machine efficiently and productively, and maintain the warranty for the duration granted by the Manufacturer.



CAUTION

**CAUTION!**

It is prohibited for persons who are not familiar with this Instructions Manual to use the Spreader.

**1.3 The intended use of the Manure Spreader**

Manure Spreader is designed for the even spreading of manure, peat, compost, etc. and for transport of agricultural products on farms and on public roads. It is not permitted to use the Spreader in any other way than the intended use.

The operator must use the machine, in accordance with its intended use, by carrying out the activities related to the correct and safe operation and maintenance of the Spreader, including:

- reading and understanding the principles of operation regarding the Spreader,
- safely and correctly operating the machine,

- maintaining the machine in a timely and regular manner,
- complying with the general safety regulations,
- complying with the provisions of the Highway Code.



**DANGER!**

The Spreader must not be used contrary to its intended purpose, in particular to:

- to transport people and animals,
- when the permissible load capacity is exceeded,
- spread and transport toxic and flammable materials,
- to distribute liquids, sand, or fibrous substances,
- to carry unsecured goods, machinery and equipment, which, while driving, can shift their position or affect the stability of the Spreader,
- to transport construction materials, individual objects, or any other materials not included in the scope of its intended use.

Making any unauthorised structural changes to the Spreader voids the Manufacturer's liability for any consequential damage.

**Table 1** Requirements regarding farm tractors

Description	Requirements	UoM
<b>Braking system</b> 2-line braking system Pressure rating of the system:	According to z PN-ISO-1728:2007 800	kPa
<b>Hydraulic system</b> Hydraulic oil Nominal pressure Oil purity	HL 46 16 20/18/15 acc. to ISO 4406-1996	MPa
<b>Electrical system</b> Electrical system voltage Connection socket	12 7-pole acc. to ISO 1724	V
<b>Tractor hitch</b> Minimum vertical load-bearing capacity of the hitch	3000	kg
Minimum power demand of the tractor	N280 (6t) – 70 N280/1 (8t) – 80 N280/2 (10t) – 90	HP
Minimum turning radius	6	m

#### 1.4 Basic accessories

The basic accessories of each Spreader include:

- Instruction Manual;
- Guarantee Card with warranty conditions;
- A bracket for a slow vehicle marking plate;
- 2-line pneumatic brakes with manual brake force adjustment;
- parking brake;
- lighting system.

#### 1.5 Transport

The Spreader is sold fully assembled and does not require any further assembly. It is delivered to the User by means of motor transport or independently, when coupled with a tractor.



CAUTION

##### CAUTION!

Observe the general health and safety regulations, regarding handling of cargo, when loading and unloading the Spreader. Persons operating the loading and unloading equipment must have the required authorisation to use such equipment.



CAUTION

##### CAUTION!

It is forbidden to attach the slings of the lifting equipment to the upper mounting brackets of the body and the adapter, to lift, load, or unload the entire Spreader.

If transported on a platform, secure the Spreader by means of clamping straps or chains with a tensioning mechanism. Such fasteners must have a valid safety certificate. Place chocks or other elements without any sharp edges under the wheels of the Spreader to prevent the machine from rolling. Attach the chocks to the platform of the means of transport applied. Special attention must be paid during loading and unloading, so as not to damage the accessories of the Spreader and its paint coating. Attach the fastening straps or chains to the shipping brackets welded to the frame of the hopper. The longitudinal members or other robust structural elements of the frame can also be used for that purpose.

Before loading the Spreader on the platform, couple it with the tractor's hitch and connect the brake system lines. Use unfolding ramps to drive the Spreader onto the low loader.



DANGER

##### DANGER!

The improper use of fasteners can lead to an accident.



CAUTION

**CAUTION!**

Pay particular attention to the angle of inclination of the ramps on the low loader. It should not exceed 10°. Excessive inclination of the ramps can damage both the Spreader and the transport trailer.

The Spreader is suitable for use on public roads as a machine attached to the **tractor's top link, and** the agricultural **lower transport hitch** should only be used if it is not possible to connect it to the tractor's top link.

Make sure that the tractor is fully manoeuvrable, before driving it on public roads. The front-axle load of the tractor must be at least 20% of the tractor's weight, which also applies when transporting and operating a loaded Spreader. If this condition is not satisfied, the front-axle of the tractor must be additionally loaded.

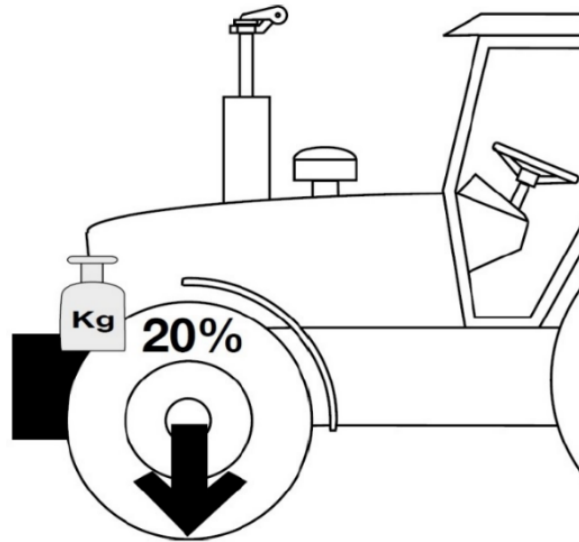

**Figure 2** Minimum front axle load of the tractor



CAUTION

**CAUTION!**

When transporting the machine on public roads, adjust the speed to the existing traffic conditions and do not exceed the speed of 30km/h.

Prior to transporting the Spreader, make sure that:

- the Spreader is properly coupled with the tractor and the hitch is secured against accidental disconnecting;
- the braking systems of both the Spreader and the tractor are working correctly;
- both the Spreader and the tractor lighting work correctly and the front position lamps of the Spreader are in transport setting;
- the ladder is folded in the transport position;
- the support wheel is folded up and raised to the maximum;

- the slide gate of the hopper is in its lowest possible position;
- the adapter cover is closed;
- the hydraulic and pneumatic hoses are properly arranged and protected against damage in transport;
- the parking brake is released.

Observe the road-traffic regulations, when transporting the Spreader on public roads. When the tractor coupled with the machine is stopped in an emergency on a public road, the driver is required to:

- stop the vehicle without causing any hazard to the safety of other traffic;
- park the vehicle as close to the right edge of the road as possible, parallel to the road centre line;
- stop the tractor engine, take off the key from the ignition switch, engage the auxiliary brake, and place chocks under the wheels of the Spreader;
- Outside a built-up area, place a warning triangle between 30 and 50 metres behind the vehicle and switch on hazard warning lights;
- In a built-up area, switch on hazard lights and place a warning triangle behind the vehicle, if it is not installed in a bracket on the rear of the machine, but always ensure that other road Users can see it clearly;
- in the case of a breakdown, undertake relevant steps to secure the area where the breakdown occurred.

### 1.6 Environmental hazards

Leaking hydraulic and gear oils can pose a direct threat to the natural environment. Carry out all maintenance and repairs in rooms with an oil-resistant surface if there is a risk of oil leakage. If oil leakage occurs, secure the source of leakage and collect the spilled oil. Use absorbent materials to collect oil residues. When collected, all pollutants must be stored in tightly closed, oil-resistant, and marked, containers.



DANGER

#### DANGER!

Store used hydraulic and gear oil or any collected residues mixed with absorbent materials in tightly sealed containers. Do not use food containers for this purpose.



CAUTION

#### CAUTION!

Dispose of all waste oil and used oil, in accordance with the applicable regulations.

It is forbidden to dispose of oil into the sewage system or water reservoirs.

### 1.7 Withdrawal from use

If the machine is to be withdrawn from use, the User must comply with the national regulations regarding withdrawing from use and recycling of end-of-life machines, applicable in a given country. Before dismantling, remove all oil from the hydraulic system and gearboxes. Reduce air pressure in the braking system to the minimum.



**DANGER**

**DANGER!**

When dismantling, use suitable tools, lifting equipment and personal protective equipment such as gloves, shoes, protective clothing, glasses, etc.

Avoid contact of oil with the skin. Prevent any oil leaks.

Dispose of all waste oil and used oil, in accordance with the applicable regulations.

When changing worn, damaged or unrepairable parts and components, send them to buy-back recycling centres.

## 2. Safety of use

### 2.1 Basic safety principles

#### 2.1.1 Obligation to provide information



CAUTION

#### CAUTION!

When being sold to a different user, the Spreader must be handed over together with the Instruction Manual, and the person purchasing the machine must undergo training, according to the guidelines provided therein.

#### 2.1.2 General safety and use regulations

Before each activation, the Spreader must be checked for safe operation:

- Observe the generally applicable safety and accident-prevention regulations, and follow the information provided in this Instructions Manual;
- Observe all the safety symbols, warning and information inscriptions attached on the Spreader which provide important guidelines for safe operation
- Start the Spreader only if all the required accessories are connected and protected against unintentional disconnecting or opening (e.g. hitch and drawbar, couplings, PTO shaft);
- Before starting work, learn how to operate all devices and controls, and their functions. It will be too late to do this, when operating the machine.
- The Spreader must not be used by persons under the influence of alcohol or other stimulants, or those not trained in its operation, or not appropriately authorised to drive motor vehicles, which also includes children.

#### 2.1.3 Safety of operation

- 1) Before using the machine, the User must read and understand the content of this Instruction Manual. Observe all the guidelines included in this Instruction Manual, during operation.
- 2) If any information contained in this Instructions Manual is unclear, please contact the seller running an authorised technical-support service on behalf of the Manufacturer, or contact the Manufacturer directly.
- 3) Careless and improper use and operation of the Spreader, as well as failure to observe the recommendations contained in this Instructions Manual, are dangerous to health and life.
- 4) Failure to observe the rules of safe use poses a threat to the health and life of the operators and third parties.
- 5) Please note that during the Spreader operation some residual risks occur, so exercising safety rules must be a priority.
- 6) All safety-related information must also be passed on to all other Users and operators of the Spreader.
- 7) Any structural and functional modifications of the Spreader release Metal-Fach Sp. z.o.o. from liability for damage to property or health impairment.



- 8) Use only the recommended PTO shafts with the correct parameters to transmit power from the shaft.
- 9) Do not use of PTO shafts without guards for power transmission.
- 10) Before starting to drive, check that the parking brake is released and that the brake force control is in the correct setting for the load status (it applies to a dual-line pneumatic system with manual brake force control).
- 11) Before starting, check the immediate vicinity (for the presence of children or bystanders). Pay particular attention, if visibility is reduced.
- 12) After you finished spreading, lower the slide gate of the hopper completely, switch off the PTO drive, switch off the floor conveyor drive. Never leave the Spreader with the gate of the hopper open, if the PTO shaft drive or the floor conveyor drive are switched on, and/or the adapter shields removed, without supervision.
- 13) It is only allowed to enter the hopper, if the Spreader has come to a complete stop, the PTO shaft is disengaged, the tractor's engine switched off, and the machine is protected against unauthorized access.
- 14) Always activate and deactivate the PTO shaft and hydraulically-controlled components from the driver's seat.
- 15) Couple the Spreader, according to guidelines. Connect it only to the recommended equipment and couple the drawbar eye with the tractor's transport hitch.
- 16) Special care must be exercised, when coupling and uncoupling the Spreader to and from the tractor.
- 17) When installing and removing any supporting and safety devices, and ladders, always place them in a position ensuring safe operation.
- 18) Follow the acceptable axle loads, total weight, and transport dimensions.
- 19) Check for the transport equipment: connection and inspection of brakes and lights, a vehicle marking plate and other protective devices.
- 20) Before driving, check the operation of the lights and brakes, and prepare the Spreader, in accordance with the recommendations provided in the "Driving on public roads" section.
- 21) Ensure that the Spreader is loaded in such a way that the material does not contaminate surfaces when travelling on public roads.
- 22) After completion of work and before driving on public roads, remove any residues of the spreading material from the external parts of the machine, to prevent it from falling and contaminating roads.
- 23) Take notice of all changes in the behaviour of the vehicle, its steering and braking performance, resulting from the coupling of a loaded Spreader.
- 24) When driving with a coupled Spreader, take into account the distribution of the load and/or inertia forces, especially if the load distribution is asymmetrical.
- 25) Do not stand within range of the material being spread.
- 26) The spreading of manure can only be carried out, if:
  - the Spreader is coupled with the tractor,
  - the tractor and Spreader unit is standing on a firm surface,
  - the front-axle load of the tractor is at least 20% of the weight of the tractor,
  - there are no persons within the spreading area,
  - the tractor is aligned with the centre line of the Spreader,
  - a safe distance from power lines is kept,
  - no strong gusts of wind occur, which can carry the spreading material away outside the permitted spreading area.

- 27) If it is necessary to carry out the final stage of spreading on a slope, align the tractor and the Spreader in the direction of the downslope. When spreading on slopes, make sure that the surface inclination does not exceed 10°.
- 28) Exercise care when opening the shields, so your fingers and hands are not crushed.
- 29) When starting the Spreader, observe the signs warning against places, where crushing, dragging, and catching hazards can occur. When coupling to and uncoupling the Spreader from the tractor, there is a risk of crushing and injuring limbs.
- 30) No person is allowed to be present between the tractor and the Spreader, unless the vehicle is protected against rolling by the parking brake and/or wheel chocks.
- 31) Secure the Spreader and the tractor against rolling, when stationary.
- 32) It is forbidden to transport the Spreader with the raised slide gate of the hopper and the adapter covers removed.
- 33) Keep a safe distance from power lines, when lifting the slide gate of the hopper.
- 34) When carrying out repair and maintenance work, which requires entering the hopper, the tractor must be stationary and protected against the risk of starting the engine and the use of the control elements by unauthorised personnel.
- 35) Always adjust your driving speed to the existing conditions. Avoid sudden turns, when driving up or down a slope.
- 36) Maintain a sufficiently safe distance, when making a U-turn with the unit.
- 37) When reversing, ensure that you have sufficient visibility (if possible, have another person to assist you).
- 38) When cornering, take into account the inertia of the Spreader.
- 39) Observe a minimum turning radius of approx. 6m, when turning and reversing.
- 40) Eliminate any functional faults in the attached devices only with the engine switched off and the ignition key removed.
- 41) In the event of a failure of the hydraulic or pneumatic systems, the Spreader must be taken out of service, until the failure has been remedied.
- 42) It is forbidden to carry out maintenance or repair work, when the hopper is loaded.
- 43) Before carrying out any repair work on the hydraulic or pneumatic systems, reduce the oil or air pressure.
- 44) In the event of injuries sustained from a strong jet of hydraulic oil, consult a doctor immediately. Hydraulic oil can penetrate under the skin or into the eye, and cause infections.
- 45) Use the hydraulic oil recommended by the Manufacturer. Never mix two different types of oil.
- 46) Use the gear oil recommended by the Manufacturer. Never mix two different types of oil.
- 47) Switch off the engine and remove the ignition key, before leaving the tractor. Engage the parking brake and secure the Spreader with a chock.
- 48) Do not exceed the maximum permissible axle loads of the Spreader.
- 49) Exceeding the permissible design load carrying capacity of the Spreader can damage the machine, cause the loss of its stability while driving, spillage of the load, as well as compromise the safety of road traffic. The braking system has been adapted to the permissible total weight of the Spreader, which, if exceeded, will considerably reduce the performance of the main brake.
- 50) It is forbidden to exceed the permissible driving speed.
- 51) The maximum permissible pressure in the hydraulic system is 16MPa.

- 52) The maximum allowable pressure in a double-line pneumatic system is 0.80 MPa, and the minimum is 0.65 MPa.
- 53) Prepare the Spreader for operation (connect its hydraulic hoses, pneumatic system, PTO shaft, etc.), when the tractor's engine is switched off and the ignition key removed.
- 54) The Manufacturer delivers the Spreader fully assembled.
- 55) Change the hydraulic (rubber) lines every 4 years.
- 56) Noise – the equivalent A-weighted emission sound pressure level (LpA) should not exceed 75dB. The peak C-weighted instantaneous sound pressure value (LCpeak) is 82±1dB.
- 57) Keep the Spreader clean.



WARNING

**WARNING!**

If operated during a storm, there is a risk of lightning striking the Spreader.

#### **2.1.4 Working with the machine**

- When working with the machine, make sure that no people or animals are present in the vicinity of the spreading area.
- It is forbidden to stand within the spreading area, since the spreading material can contain stones, fragments of wood, or other objects.
- Before commencing work, check the condition of the adapter blades and their fasteners.
- Before loading, check the tension of the chains of the floor conveyor. Regularly check the tension of the conveyor chains.
- When working close to roads, drainage ditches, plot boundaries, and water bodies, make sure that designated spreading zone is not exceeded.

## 2.1.5 Pneumatic and hydraulic systems



CAUTION

### CAUTION!

The pneumatic braking system operates under high pressure. Before starting work on the system, switch off the tractor engine, secure the Spreader with the parking brake and support chocks and purge it.

- When connecting pneumatic lines to the pneumatic system of the tractor, make sure that the valves on the tractor and Spreader sides are not under pressure.
- Check the pneumatic connection on a regular basis and change damaged and ageing parts. When changing lines, comply with the technical requirements of the Manufacturer. Change flexible pneumatic lines every 5 years, unless damage is found earlier.
- Air leaks from the pneumatic braking system are not allowed.
- The hydraulic system is under high pressure during operations.
- Use the hydraulic oil recommended by the Manufacturer. Never mix two different types of oil.
- Regularly check the technical condition of the hydraulic connections and hoses.
- When connecting the hydraulic hoses to the tractor, make sure that the hydraulic systems of the tractor and the Spreader are not under pressure. If necessary, reduce the residual pressure of the system.
- In the event of injuries sustained from a strong jet of hydraulic oil, consult a doctor immediately. Hydraulic oil can penetrate under the skin or into the eye, and cause infections.
- Repair work on the pneumatic or hydraulic systems may only be carried out by an authorised representative of the Manufacturer of the Spreader.
- In the event of a failure of the hydraulic or pneumatic systems, the Spreader must be taken out of service, until the failure has been remedied.



Change flexible pneumatic lines every 5 years, unless damage is found earlier.

Change rubber hydraulic hoses every 4 years, regardless of their technical condition, unless a fault has been found earlier.



CAUTION

### CAUTION!

The required purity of hydraulic oil is 20/18/15, according to ISO 4406-1996.

### 2.1.6 Working with the PTO shaft

- The Spreader may only be connected to the tractor by means of an appropriately selected PTO shaft recommended by the Manufacturer.
- Before starting work, read the Instruction Manual of the PTO shaft and follow its guidelines.
- Connect and disconnect the PTO shaft only when:
  - the Spreader is coupled with the tractor hitch,
  - the tractor's engine is switched off,
  - the key is removed from the ignition switch,
  - the parking brake is pulled up,
  - and the PTO shaft is switched off.
- Before starting the tractor hitched with the Spreader, make sure that the PTO shaft drive in the tractor is switched off.
- The PTO shaft must have guards.
- It is forbidden to use the PTO shaft without its guards or with damaged components.
- Install the power take-off shaft, in accordance with the Instruction Manual provided by the Manufacturer of the shaft.
- Secure the guards of the PTO shaft against rotating, using chains. Fasten the chains of the shaft to the permanent structural components of the Spreader and the tractor.
- The guards of the PTO shaft are marked indicating which end of the shaft should be installed on the machine side and which on the tractor side. The protective couplings must always be fitted on the machine side.
- After installing the PTO shaft, make sure that it is correctly and safely connected to the tractor and the Spreader.
- Each time you start the Spreader, make sure that the PTO guards are in good technical condition, and that they are correctly positioned. Change any damaged or faulty components for new ones.
- When working with and maintaining the machine, it is forbidden to wear loose clothing, which can be caught by the rotating parts of the PTO shaft. Contact with a rotating PTO shaft can result in a serious injury or death.
- When working in conditions of reduced visibility, use the tractor's service lights to ensure adequate sight of the working PTO shaft and its immediate vicinity.
- Transport and store the PTO shaft horizontally with its chains fastened together, to prevent damage to the guards and other components.
- It is forbidden to overload the PTO shaft and the drive system of the Spreader's adapter. It is not allowed to start the PTO shaft of the tractor in a sharp manner. Before starting the PTO shaft, make sure that the direction of rotation is correct.
- **When in operation, keep the rotational speed of the PTO shaft at 540 rpm.** Operating at different speeds can damage the machine or its components.
- Switch off the PTO shaft drive, whenever there is no need to drive the machine, or when the tractor and Spreader are oriented at an unfavourable angle.
- Do not exceed the maximum permissible working length of the PTO shaft.
- When uncoupling the PTO shaft from the tractor, place it in a special holder designed for that purpose.

- It is forbidden to use chains for suspending or supporting the PTO shaft, when the Spreader is parked or transported.

## **2.2 Residual Risk**

### **2.2.1 Information about Residual Risk**

Although METAL-FACH in Sokółka assumes responsibility for the machine design and structure, in order to eliminate hazards, it is inevitable that some risks are present during the Spreader's operation.

Residual risk can result from incorrect behaviour by the Spreader's operator, e.g. carelessness, ignorance, or improper actions. The following prohibited actions cause the highest level of risk:

- 1) The operating of the Spreader by minors or persons without authorisation to drive a tractor, as well as by persons who have failed to read the Instruction Manual.
- 2) The operating of the Spreader by persons, who are sick or under the influence of alcohol or other intoxicating substances.
- 3) Using the Spreader for purposes other than those described in the Instruction Manual.
- 4) Standing between the tractor and the Spreader, while the tractor's engine is running.
- 5) Oil leakage and sudden movement of components caused by rupturing of hydraulic hoses.
- 6) Standing on the machine while operating or transporting.
- 7) Bystanders, children in particular, standing close to the running Spreader.
- 8) The presence of persons or animals in areas not visible from the position of the operator.
- 9) Cleaning, maintaining, and inspecting mechanisms of the Spreader connected to the PTO shaft, while the tractor's engine is running.
- 10) Checking its technical condition, when the Spreader is in operation.
- 11) Operating a defective power take-off shaft.
- 12) Exceeding the permitted speed and load carrying capacity.
- 13) Making modifications to the machine without the Manufacturer's consent.

When specifying the residual risks, we assume that the Spreader is a machine designed and manufactured, according to state of the art in the year of its manufacture.

### **2.2.2 The Assessment of Residual Risk**

Residual risk can be reduced to the minimum by applying the following recommendations:

- 1) Adhering to the safety rules described in the Instruction Manual.
- 2) Using common sense, when operating the machine.
- 3) Do not hurry, when operating the machine.
- 4) Maintain a safe distance from the restricted and dangerous places.
- 5) Do not reach into dangerous and/or restricted places with your hands.
- 6) Do not stand on the machine, while it is in operation.
- 7) Have repair and maintenance work performed by trained personnel.
- 8) Wear the appropriate protective clothing.

- 9) Prevent unauthorized access, especially children, to the machine.
- 10) Make sure there is no person present in the blind spot (especially when reversing and coupling).



CAUTION







**CAUTION!**

Failure to comply with the instructions and guidance provided in this Manual can result in the occurrence of residual risks!









### **2.3 Warning and information stickers**



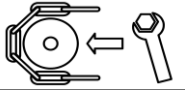
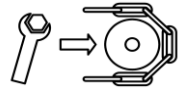

The Manure Spreader is marked with information and warning stickers. The User is obliged to ensure that the inscriptions, warnings and information pictograms provided on the Spreader are legible throughout the working life of the Spreader. If any information or warning sticker has been damaged or removed, have it ordered from the Manufacturer or the point of sale the machine was purchased from. Where necessary, re-apply stickers onto any new components installed during repair work. When cleaning, do not direct a strong jet of water at the labels and do not use any solvents.

**Table 2** information and warning stickers

No.	Safety symbol (sign)	Meaning of the symbol (sign) or content of the inscription	Location on the Spreader
1.		Caution! Before you start operating the machine, read the Instruction Manual.	On the front panel of the hopper
2.		Caution! Turn off the engine and remove the key before commencing any maintenance or repair work.	On the front panel of the hopper
3.		Caution! Risk of electric shock. Keep a safe distance from power lines.	On the front panel of the hopper
4.		Caution! Crushing of torso hazard. Stay clear of the area where the articulated coupling joints rotate, if the engine is running.	On the front panel of the hopper
5.		Risk of hand or arm being drawn in or caught by a driven, unprotected chain, or drive belt.	On the right and left panels of the hopper
6.		Caution! Thrown or flying materials. Hazard to the whole body. Keep a safe distance from the machine.	On the adapter frame
7.		Caution! Hand crushing hazard. Keep a safe distance from moving parts.	On the adapter frame

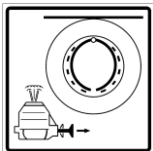

8.		<p>Caution!            Danger of hand or upper torso being dragged in by the rotors of the adapter.            Do not reach into the area of rotating parts.</p>	<p>On the rear panel of the hopper. Near the adapter.</p>
9.		<p>Caution!            Risk of falling.            Do not travel on platforms or ladders.</p>	<p>On the stanchion of the front panel</p>
10.		<p>Caution!            Danger of crushing toes or a foot.            Keep a safe distance from the support foot and the drawbar.</p>	<p>At the support foot</p>
11.		<p>Risk of crushing fingers or hands from the accessible moving machine parts.</p>	<p>On the right and left panels of the hopper</p>
12.		<p>Attachment points of the transport tie down straps</p>	<p>At the attachment points</p>
13.		<p>Lubricating points</p>	<p>At the back of the floor conveyor and suspension</p>
14.		<p>Tensioning the floor conveyor chain</p>	<p>On the left panel of the hopper</p>
15.		<p>Tensioning the floor conveyor chain</p>	<p>On the right panel of the hopper</p>
16.		<p>Speed limit of 30 km/h</p>	<p>On the lighting beam</p>

17.		Pneumatic brake release mechanism	On the front panel of the hopper
18.		PTO rotational speed	On the front beam of the top frame
19.		Jacking point	On the driving axles
20.		Adjust the length of the shaft	On the hitch
	<b>Warning inscriptions</b>	<b>Meaning of the symbol (sign) or content of the inscription</b>	<b>Location on the Spreader</b>
21.		Check chain tension regularly	On the right and left panels of the hopper
22.		Do not enter the hopper when the drive is enabled	On the right-hand panel of the hopper. On the ladder
23.		Tighten the wheel nuts after a few kilometres and then periodically	Above the road wheels
24.		Adapter weight: 440kg Adapter weight: 470 kg	On the adapter frame
25.		Load capacity: N280 – 6t N280/1 – 8t N280/2 – 10t	On the front panel of the hopper
26.		Switch off the PTO shaft drive when cornering.	On the front panel of the hopper
27.		Use a hitch for single-axle trailers to couple the trailer.	On the front panel of the hopper



CAUTION

**CAUTION!**

The User of the Spreader must maintain the legibility of all warning inscriptions and signs provided on the Spreader throughout the working life of the machine. If they are damaged or destroyed, change them to new ones.

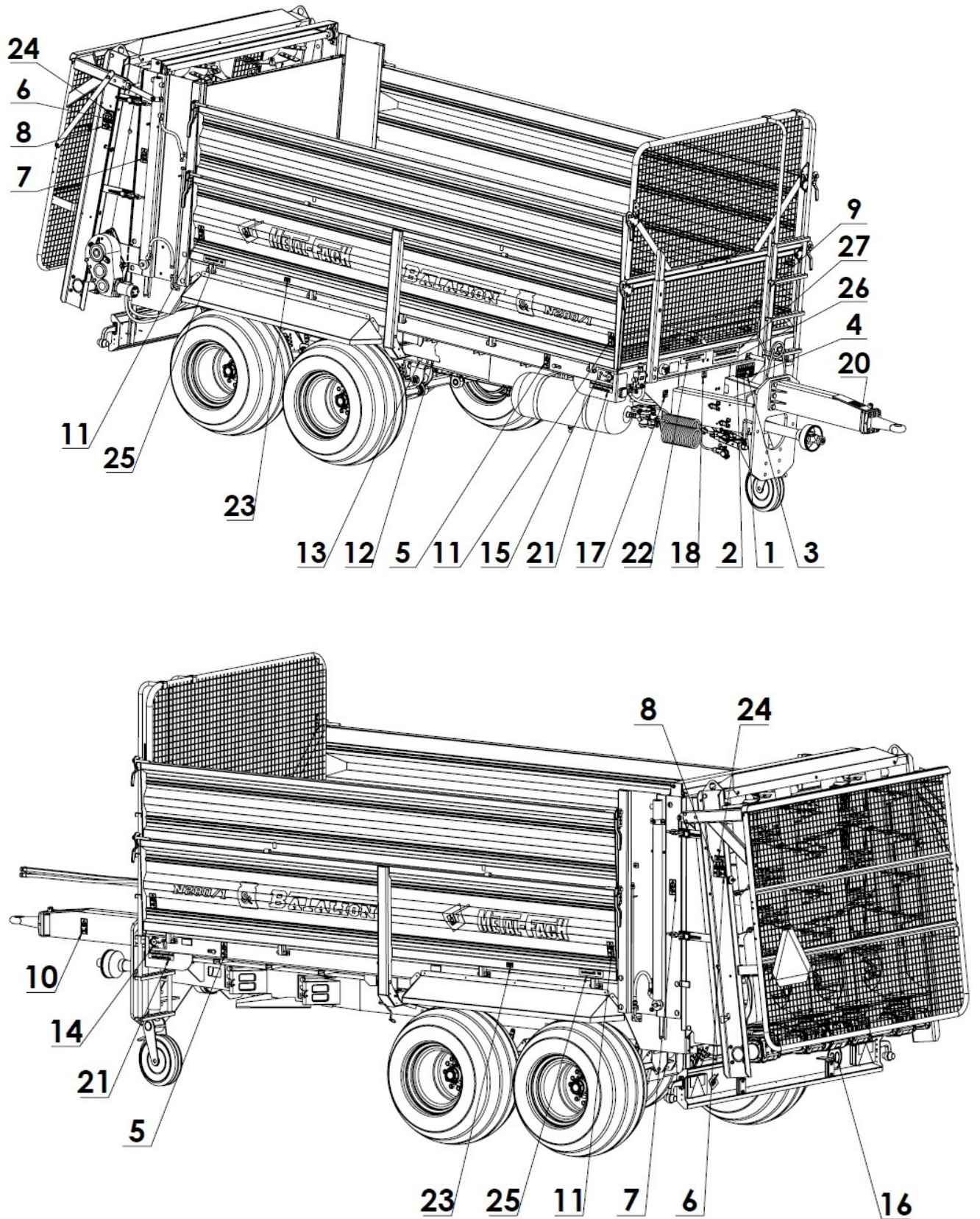

**Figure 3** The locations of warning and information stickers

### 3. The Design and Principles of Operation

#### 3.1 Basic Technical Data

**Table 3** Basic Technical Data

No.	General Data					
1.	Type of vehicle	Manure Spreader				
2.	Suspension	Tandem on 4 leaf springs				
3.	Type (Model)	N280 (6t); N280/1 (8t); N280/2 (10t) <b>BATALION</b>				
4.	Type of bodywork	Segmented hopper				
5.	The location of the rating plate	The front beam of the top frame				
<b>Overall dimensions</b>						
		<b>UoM</b>	<b>N280 (6t)</b>	<b>N280/1 (8t)</b>	<b>N280/2 (10t)</b>	
6.	Length	mm	6696	6696	7100	
7.	Width	Wheels 400/60-15.5 14PR	mm	2350		
		Wheels 500/50-17 14PR		2350		
8.	Height	Wheels 400/60-15.5 14PR	mm	2680	-	-
		Wheels 500/50-17 14PR		2695	2800	2790
9.	Wheel track	mm	1800			
<b>Loading height</b>						
10.	Loading height	Wheels 400/60-15.5 14PR	mm	2150	-	
		Wheels 500/50-17 14PR		2165	2250	2350
11.	Loading height with extensions	Wheels 400/60-15.5 14PR	mm	NO EXTENSIONS		
		Wheels 500/50-17 14PR				
12.	Ground clearance of the floor	Wheels 400/60-15.5 14PR	mm	1175	-	
		Wheels 500/50-17 14PR		1190		
<b>Internal dimensions of the hopper (segmented hopper)</b>						
13.	Length	mm	4120		4620	
14.	Width	mm	1960			
15.	Height	mm	1000 (panels 500+500)	1100 (panels 500+600)	1200 (panels 600+600)	
16.	Height with extensions	mm	NONE			
<b>Performance Parameters</b>						
17.	Permissible total weight	kg	9280	11460	13660	
18.	Load capacity	kg	6000	8000	10000	

		UoM	N280 (6t)	N280/1 (8t)	N280/2 (10t)	
19.	Permissible axle load	kg	8000	9900	11950	
20.	Kerb weight (max)	kg	3280	3460	3660	
21.	Drawbar eye load (max)	kg	1280	1560	1710	
22.	PTO rotational speed	rpm	540			
23.	Tractor power demand (min.)	HP	70	80	90	
24.	Cargo space	m <sup>3</sup>	8.07	8.9	10.8	
25.	Cargo space with extensions	m <sup>3</sup>	NONE			
26.	Effective spreading width	m	8			
27.	Maximum spreading width	m	8-12			
28.	Permissible transport speed	km/h	30			
29.	Working speed	km/h	4-10			
<b>Other Information</b>						
30.	Pressure in the hydraulic system (max)	MPa	16			
31.	Maximum pressure in the 2-line pneumatic braking system	MPa	0.80			
32.	Electrical system voltage	V	12			
33.	Types of hitch	Type of shock absorption	-	Unsprung, screwed on permanently		
		Coupling with the tractor		Lower hitch	YES	
				Upper hitch	YES	
34.	Drawbar eyes (types)	Standard	mm	Drawbar eye Ø40		
		Optional		Rotational drawbar eye Ø50		
		Optional		Drawbar eye Ø50		
		Optional		K80 ball drawbar eye		
35.	Driving axles	Standard	mm	Permanent □70		
		Optional		NONE		
36.	Brakes	Standard	-	Mechanical, drum, pneumatically-controlled		
		Optional		Pneumatic 2-line with ALB		
		Optional		Hydraulic 1-line		
		Optional		Hydraulic-pneumatic		
37.	Parking brake	-	Mechanical, drum, manually controlled via a worm gear			
38.	Tyre size	Standard	-	400/60-15.5 14PR	500/50-17 14PR	500/50-17 14PR
		Optional		500/50-17 14PR	-	-
39.	Adapter type	-	Vertical 4-rotor 2000 x 1180	Vertical 4-rotor 2000 x 1480		
			Fastened with eccentric clamps			

		UoM	N280 (6t)	N280/1 (8t)	N280/2 (10t)
40.	Adapter weight		kg	440	470
41.	Oil in the hydraulic system (HL-46)		L	6	
42.	Oil in the gearbox of the floor conveyor (gearbox oil 80W90)			4.3	
43.	Oil in the gearbox of the spreading adapter (gearbox oil 80W90)			12	
44.	Chain of the floor conveyor	Chain link	mm	Ø10 (10x35)	
		Number of rows	pcs.	4	
45.	Tensioning the chain of the floor conveyor	Tensioning mechanism on the side of the hopper	pcs.	2	
46.	The chain wheel scrapers in the floor conveyor	Front	-	YES	
		Rear		YES	
47.	Safeguards (overload couplings)	Adapter	-	PTO front, shear pin, WPT rear, friction clutch	
		The floor-conveyor gear		The cross-directional hydraulic valve	
48.	The slide gate-lifting indicator		-	NONE	
49.	The thickness of the hopper panel (steel grade)		mm	2 (S355)	
50.	Thickness of the hopper floor (wood class)		mm	34 (impregnated spruce board)	
51.	The wheel chocks included in the delivery		-	YES	
52.	Wheel mudguards	Optional	-	YES	
53.	Deflectors	Standard		NONE	
		Optional		YES	
54.	Adapter rear flap (cover)		-	Mesh, mechanically lifted up together with the slide gate	
55.	External ladder		-	Fixed permanently to the front panel of the hopper	
56.	Support wheel	Standard	-	Mechanical	
57.	Extensions	Optional	-	NONE	
<b>The hydraulic system</b>					
58.	The slide gate of the hopper		-	Hydraulically controlled	
59.	The drive of the floor conveyor		-	Hydraulically controlled	
60.	No distributor	Standard	-	2 pairs of conduits (2 sections)	
61.	Distributor	Optional	-	1 pair of conduits	
62.	Hydraulic brake / hydraulic-pneumatic brake	Optional	-	Additionally 1 hydraulic line	

**The User must observe the permissible transport speeds commensurate with the maximum load carrying capacity of the Spreader.**

If using a different brand of tyres, observe the parameters regarding that particular brand.



**DANGER**

**DANGER!**

Failure to adhere to the permissible speeds, tyre and axle loads can result in a serious accident.

### **3.2 The Design and Principles of Operation**

The design of the Spreader is shown in Figure 4. The main components of the Spreader include the bottom frame (21) on which the top frame (20) is mounted. The following components are mounted to the bottom frame (21): tandem sprung (5). Additionally, the front section of the bottom frame has a factory-mounted hitch adapter (2) with a drawbar eye (1), which comes in various configurations, depending on the customer's order. A support wheel (3) is also part of the standard accessories.

The top frame (20) features such components as the front panel (8), which contains the front mesh (19) and the ladder (13). There are side panels (14) on both sides. Both side panels are supported by stanchions (17) mounted on both sides of the Spreader.

The operating element of the Manure Spreader is a floor conveyor (24) equipped with bars. Spreading is carried out using the adapter (6) with a rear mesh (11), which protects against accidental injury. Each Spreader is equipped with a slide gate, lifted by means of hydraulic cylinders located on both sides of the machine. After removing the adapter (6), the Spreader can be used as a tipping manure conveyor.

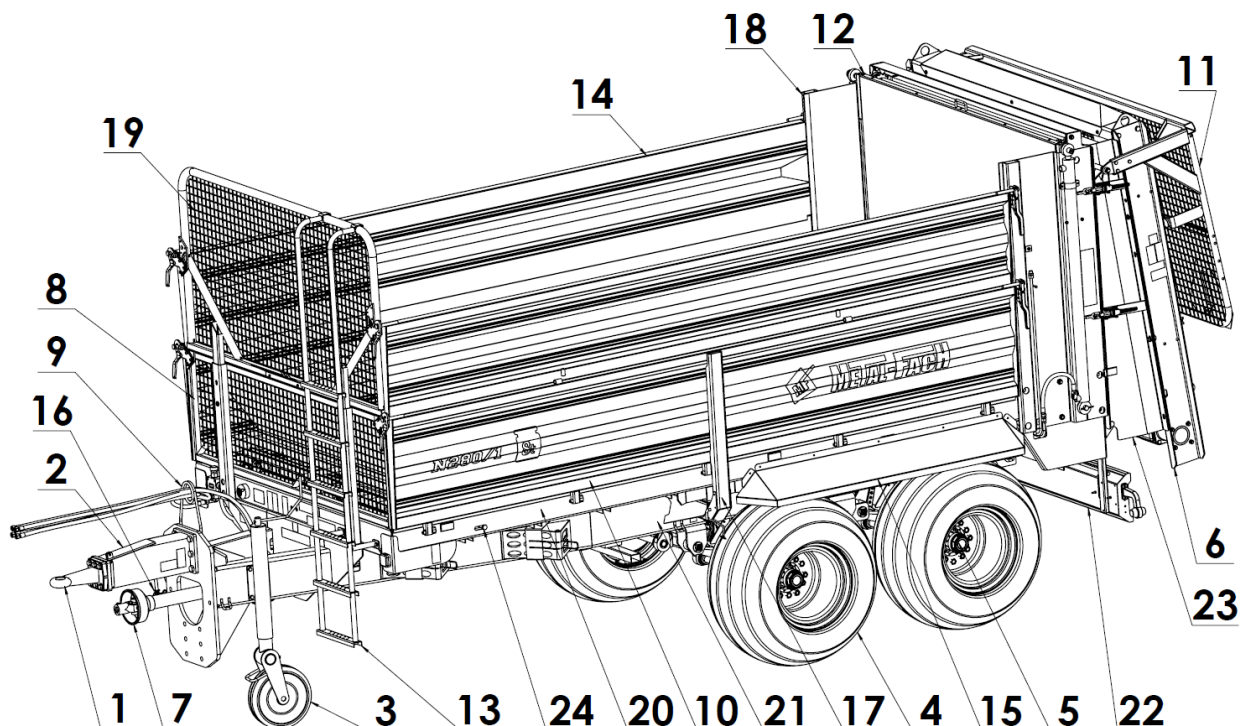

**Figure 4** General design of the Manure Spreader:

1 - drawbar eye, 2 - hitch, 3 - support wheel, 4 - wheels, 5 - suspension, 6 - 4-rotor adapter, 7\* - adapter drive unit, 8 - front panel, 9 - grommet, 10 - side panel, 11 - rear mesh, 12 - slide gate, 13 - ladder, 14 - extensions, 15\* - mudguards, 16 - hand brake, 17 - stanchion, 18 - panel base, 19 - front mesh, 20 - top frame, 21 - bottom frame, 22 - lighting beam, 23 - adapter connection, 24 - floor conveyor, \* - available as an option

### 3.2.1 The feeding mechanism

The feeding unit consists of a floor conveyor, a feeder roller, and a tensioning system. The entire mechanism is driven by the hydraulic system of the tractor.

The floor conveyor consists of two pairs of chains connected by scraping bars. The chains are driven by sprocket wheels mounted on the feeder roller. The feeder roller is driven by the reduction gear and the hydraulic motor. The front part of the Spreader contains a tensioning system that controls the tensioning of the chains of the feeder. The conveyor sprockets are fitted with scrapers to prevent the sprockets from clogging.

The floor conveyor is protected against damage by an overload hydraulic valve located at the hydraulic motor. If overloaded or blocked mechanically, the conveyor is paused immediately.



### 3.2.2 The drive unit of the adapter

The drive unit of the adapters consists of a PTO shaft coupled with the tractor, rotating at the nominal torque of 680Nm with a shear-pin coupling, a split quill shaft that transmits power from the front part to the rear part of the Spreader, and a PTO shaft that transmits power to the adapter.

**Table 4** The power take-off shafts

Symbol of the tractor's PTO shaft	Nominal torque	L min.	L max	Transmitted power	Overload coupling
	Nm	mm	mm	kW	Nm
60970/602.K6-1/5NW*	680	1010	1745	38	2000
60980/602.K6-1/4NW	680	1210	2000	38	2000
60680/S602.K6-1/5NW**	680	1210	2000	38	1860
Symbol of the adapter's PTO shaft	Nominal torque	L min.	L max	Transmitted power	Overload coupling
610442/602.C603E/5NW	630	710	1145	36	1300

### 3.2.3 The 4-rotor vertical spreading adapter

The 4-rotor vertical adapter is used for shredding and scattering the material supplied by the floor conveyor. The adapter is mounted in the rear section of the Spreader. The adapter is driven by the drive unit and the PTO of the tractor.

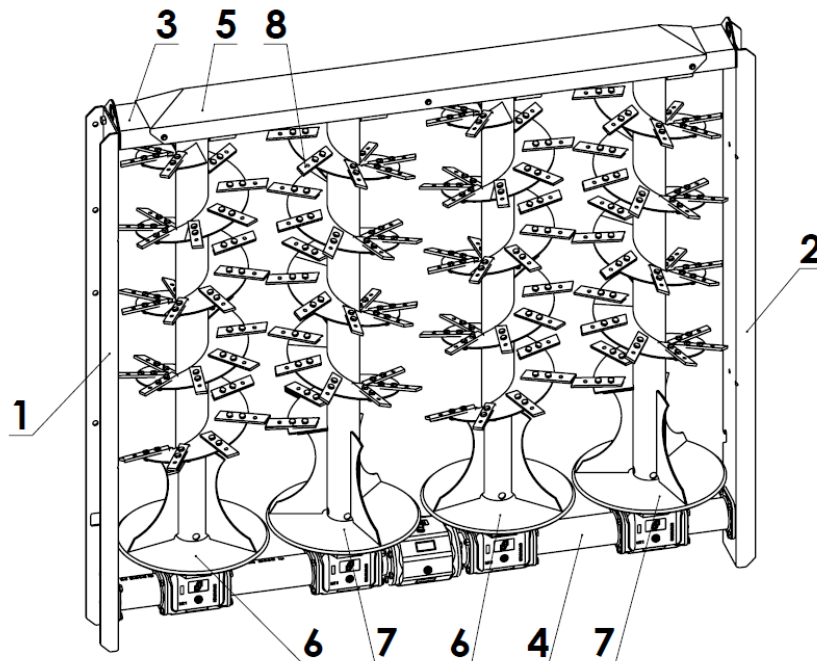

**Figure 5** 2-rotor vertical adapter

The adapter consists of the left side beam (1), the right side beam (2) and the upper beam (3), all of which form the frame of the adapter. In its lower part, there is a gear (4) featuring vertical rotors (6) and (7), which are installed in such a way that the material is spread along two paths. The main workings tools are the replaceable blades (8) screwed on to the

rotor segments. When revolving, the rotors shred the fed material and eject it backwards and sideways.

The bottom section of the rotors features discs with blades, which increase the spreading width of the material. The top beam is finished with a top cover (5) which covers the bearings of the adapter drums.

The adapter is connected to the hopper using eccentric clamps. To disassemble the adapter, do the following:

- disconnect the PTO shaft from the adapter gear,
- remove the adapter covers,
- uncouple the adapter from the hopper,
- use a lifting device with the minimum lifting capacity of 500kg to remove the adapter,
- after removing the adapter, place it on a solid surface and secure against tipping over.

### **3.2.4 Adapter cover**

The back cover of the adapter is made of mesh and it is designed to protect outsiders against sharp parts protruding from the adapter drums (i.e. the blades), and to protect against the rotating parts that could be accidentally triggered by improper handling.

The rear cover is controlled automatically, when activating the lifting of the slide gate (the inner hydraulic panel). The sliding movement of the slide gate upwards causes the rear cover to swing upward by means of a system of towing eyes. The downward movement of the slide gate lowers the rear cover.

### **3.2.5 Slide gate of the hopper**

Hoppers in the N280 series Manure Spreaders feature a slide gate in the hopper. It separates the transported material from the adapter. It is supported in the side guides which seal and protect the material against penetrating outside the hopper. The bottom section of the slide gate is reinforced, which protects the gate against damage resulting from excess manure pressing on it. The bottom section of the gate (the same as at the front of the hopper) features a rubber sealing belt matching the shape of the conveyor chains.

The slide gate is opened by hydraulic cylinders controlled by the external hydraulic system of the tractor, which lift the gate upwards.

### **3.2.6 The main braking system**

The Spreader can be equipped with one of the three types of main braking systems:

- A two-line pneumatic system (Figure 6),
- A two-line pneumatic system with an ALB valve (Figure 7),
- A single-line hydraulic braking system (Figure 9),
- A pneumatic-hydraulic braking system (Figure 10),
- A pneumatic-hydraulic braking system with an ALB valve (Figure 11).

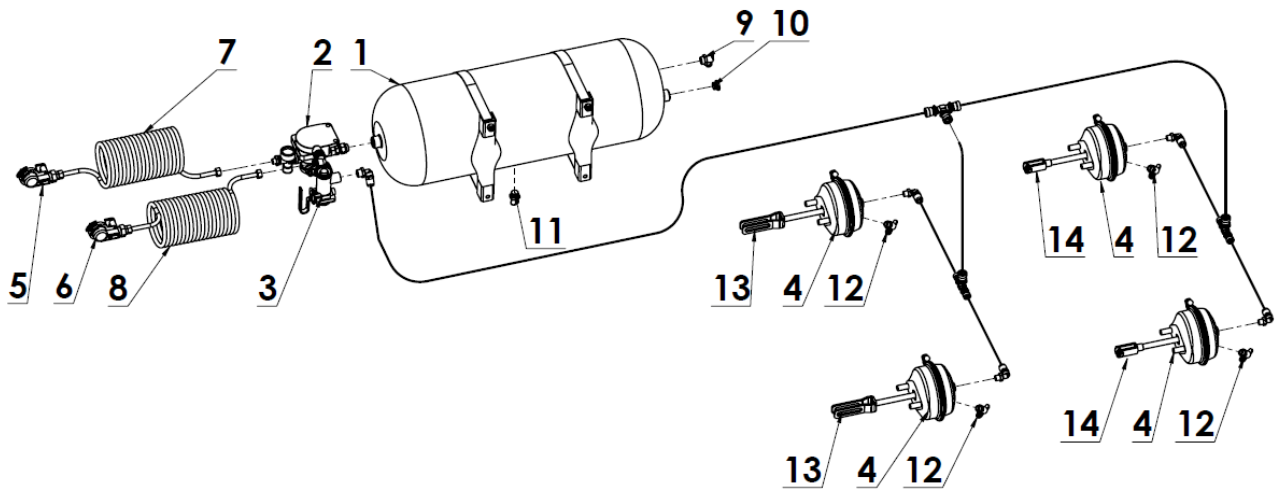

**Figure 6** 2-line pneumatic braking system:

1 - air tank, 2 - control valve, 3 - braking-force regulator, 4 - pneumatic cylinder, 5 - conduit connection (red), 6 - conduit connection (yellow), 7 - helical conduit (red), 8 - helical conduit (yellow), 9 - air tank monitoring connection, 10 - plug, 11 - drain valve, 12 - pneumatic cylinder monitoring connection, 13 - long fork of the pneumatic cylinder, 14 - short fork of the pneumatic cylinder

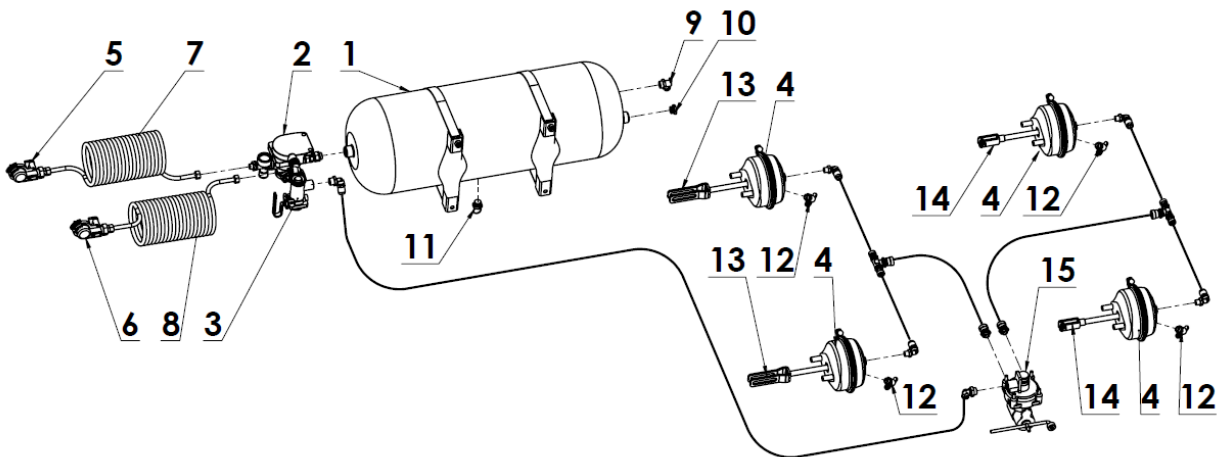

**Figure 7** 2-line pneumatic braking system with an ALB valve:

1 - air tank, 2 - control valve, 3 - braking-force regulator, 4 - pneumatic cylinder, 5 - conduit connection (red), 6 - conduit connection (yellow), 7 - helical conduit (red), 8 - helical conduit (yellow), 9 - air tank monitoring connection, 10 - plug, 11 - drain valve, 12 - pneumatic cylinder monitoring connection, 13 - long fork of the pneumatic cylinder, 14 - short fork of the pneumatic cylinder, 15 - ALB valve

The main brake is activated from the driver's seat by pressing the brake pedal of the tractor. The pneumatic control valve (2) applied in the pneumatic system actuates the brakes of the Spreader simultaneously with the brakes of the tractor.

In the event of an accidental disconnection of the conduits (5) and (6) the control valve will automatically activate the brakes of the machine.

The braking-force regulator (2) – see Figure 8 – applied in the pneumatic braking system adjusts the braking force, according to the hopper load. Switching to the correct working mode is done manually, by shifting the position of the lever (4). This is done by the operator, before starting to drive. The following three working positions are available: (A) “UNLADEN”, (B) “HALF LOAD”, (C) “FULL LOAD”.

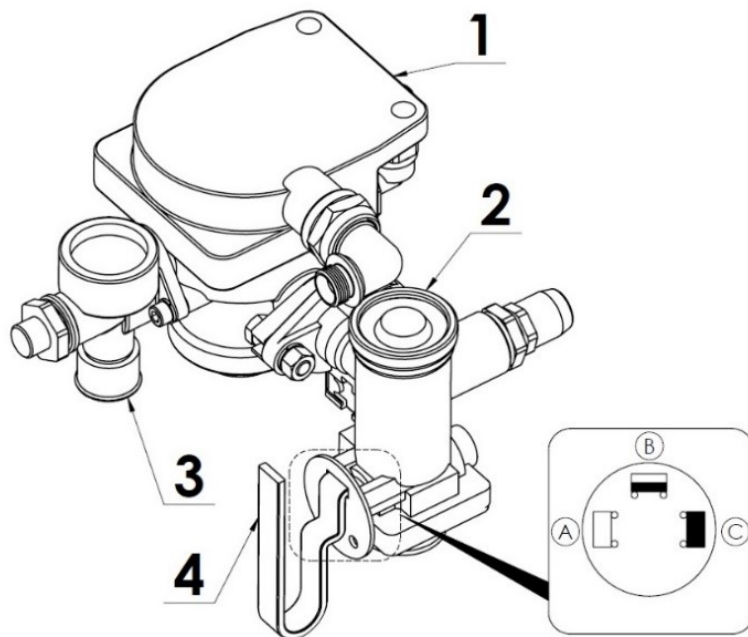

**Figure 8** The control valve and the braking-force regulator for 2+line pneumatic brakes:  
 1 - control valve, 2 - braking-force regulator, 3 - brake release button, when the Spreader is parked, 4 - the lever for working mode selection: (A) "UNLADEN", (B) "HALF LOAD", (C) "FULL LOAD".



CAUTION

**CAUTION!**

It is not allowed to drive with a full load, when the following settings of the braking-force regulator are selected: (A) "UNLADEN" and (B) "HALF LOAD" Failure to follow this guidance can result in an accident.

The Spreader can be optionally equipped with a 1-line hydraulic braking system - see Figure 9. The brake is activated from the driver's seat by pressing the brake pedal of the tractor. The Spreader brake is supplied and activated directly from the hydraulic braking system of the tractor. In the event of an accidental disconnection of the Spreader coupled with the tractor, the emergency valve (1) will activate the brakes of the machine by means of the chain (5).

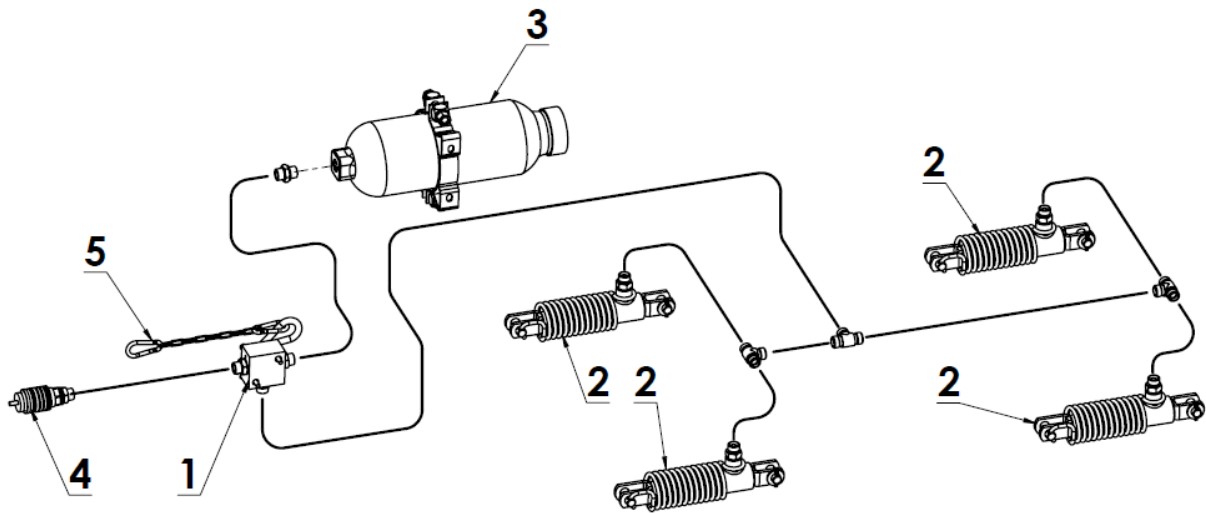

**Figure 9** 1-line hydraulic braking system:

1 - emergency valve, 2 - brake actuator, 3 - hydraulic accumulator, 4 - hydraulic quick coupling, 5 - actuation chain for emergency valve

Another option for the braking system is the hydraulic-pneumatic braking system and the hydraulic-pneumatic braking system with an ALB valve. This system is a combination of the 2-line hydraulic and pneumatic braking systems. Depending on the type of trailer brakes featured in a particular tractor, it is possible to connect a hydraulic or a pneumatic braking system, respectively – see Figure 10 & 11.

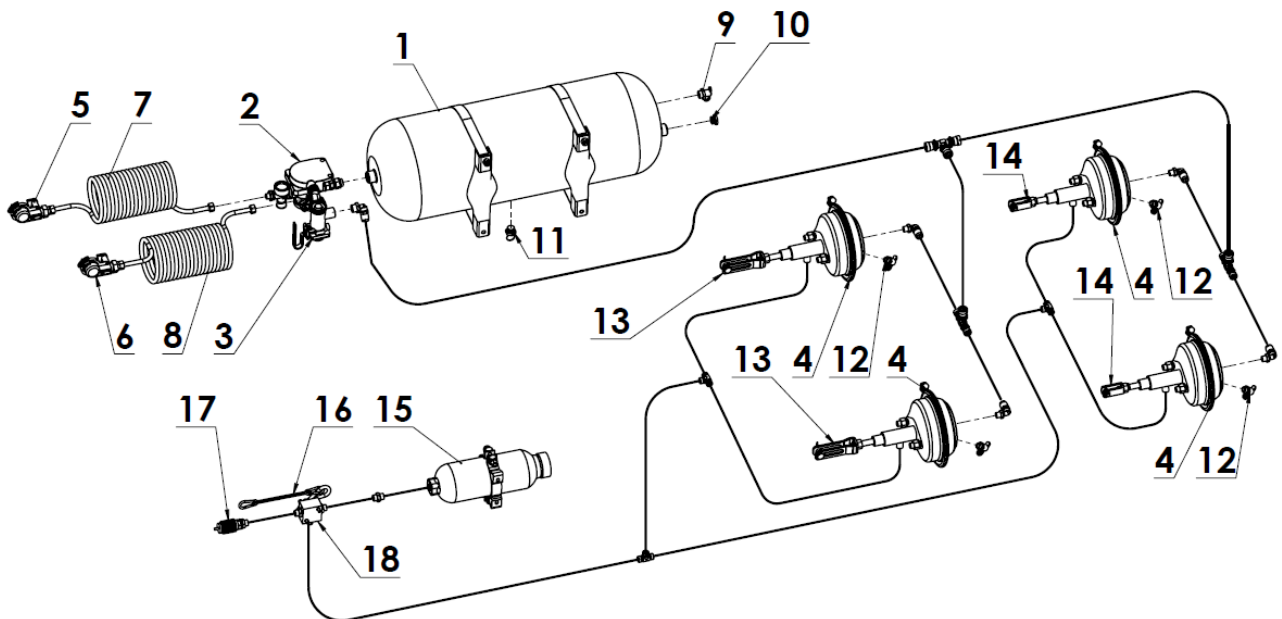

**Figure 10** The hydraulic-pneumatic braking system:

1 - air tank, 2 - control valve, 3 - braking-force regulator, 4 - pneumatic-hydraulic cylinder, 5 - conduit connection (red), 6 - conduit connection (yellow), 7 - helical conduit (red), 8 - helical conduit (yellow), 9 - air tank monitoring connection, 10 - plug, 11 - drain valve, 12 - pneumatic-hydraulic cylinder monitoring connection, 13 - long fork of the pneumatic-hydraulic cylinder, 14 - short fork of the pneumatic-hydraulic cylinder, 15 - hydraulic accumulator, 16 - actuation chain for emergency valve, 17 - hydraulic quick coupling, 18 - emergency valve.

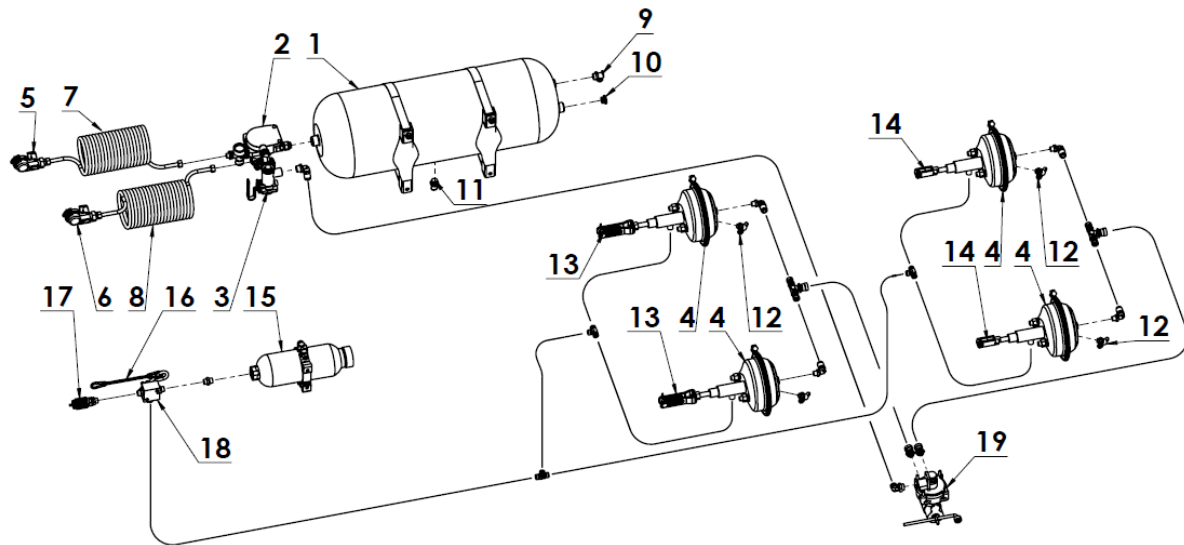
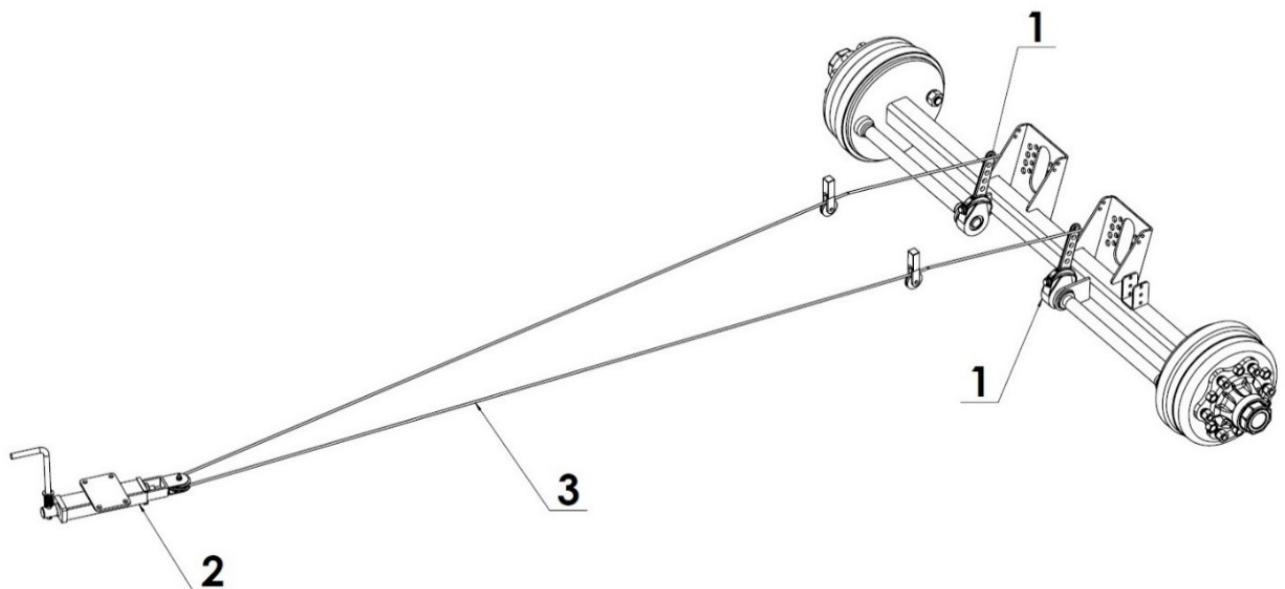

**Figure 11** The hydraulic-pneumatic braking system with an ALB valve:

1 - air tank, 2 - control valve, 3 - braking-force regulator, 4 - pneumatic-hydraulic cylinder, 5 - conduit connection (red), 6 - conduit connection (yellow), 7 - helical conduit (red), 8 - helical conduit (yellow), 9 - air tank monitoring connection, 10 - plug, 11 - drain valve, 12 - pneumatic-hydraulic cylinder monitoring connection, 13 - long fork of the pneumatic-hydraulic cylinder, 14 - short fork of the pneumatic-hydraulic cylinder, 15 - hydraulic accumulator, 16 - actuation chain for emergency valve, 17 - hydraulic quick coupling, 18 - emergency valve, 19 - ALB valve.

### 3.2.7 Parking brake

The parking brake is used to immobilise the Spreader, while it is parked. The components of the system are shown in Figure 12.



**Figure 12** Parking brake:

1 - brake-expander lever, 2 - brake tension, 3 - steel cord

The tensioning mechanism (2) is fixed to the right-hand side of the hopper. The expander levers (1) of the driving axle are connected to the crank device by means of a steel cord (3). Turning the crank of the tensioning mechanism clockwise tightens the cord (3) and

swings the expander lever to activate the brakes of the Spreader. The brake is released by turning the crank of the tensioning mechanism anticlockwise.

### 3.2.8 The electrical and lighting systems

The electrical system of the Spreader can supply power from a 12VDC power source of the electrical system of the tractor. Connect the electrical system of the Spreader to the electrical system of the tractor system by means of a connecting cable supplied with the machine. The wiring diagram is shown in Figure 13 and the arrangement of lights in Figure 14.

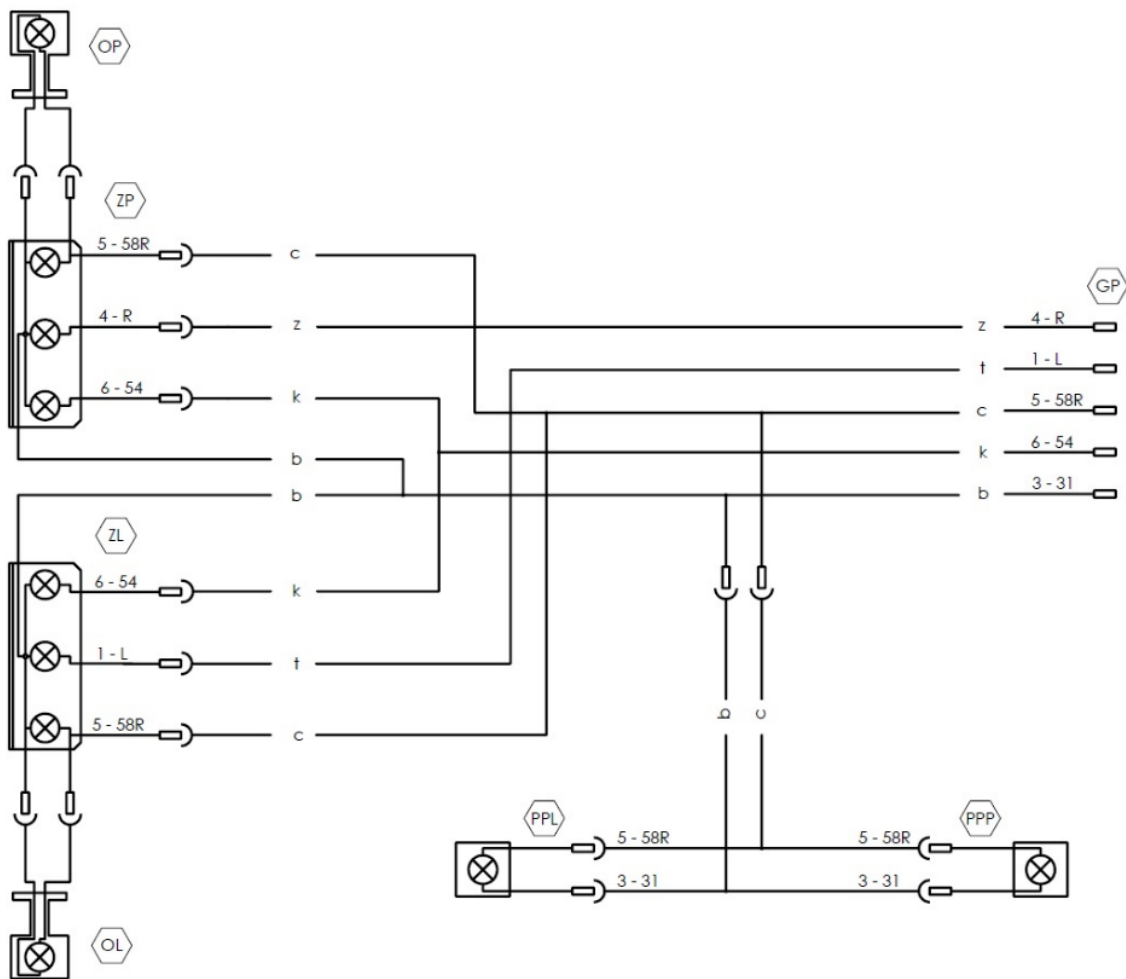

**Figure 13** Wiring Diagram

The colour code for wires, electrical parts and connections are given in Tables 5, 6 and 7.

**Table 5** Cable colour code

Designation	Colour
c	Black
b	White
k	Red
t	Green
z	Yellow

**Table 6** List of codes for electrical parts

Symbol	Name
ZP	Rear-light cluster, right
ZL	Rear-light cluster, left
GP	Connection socket
OP	Marker lamp, right
OL	Marker lamp, left
PPP	Front running light, right
PPL	Front running light, left

**Table 7** The designation of the terminals in the connection socket

Designation	Function
1 - L	Traffic indicator lamp, left
3 - 31	Earth
4 - R	Traffic indicator lamp, right
5 – 58R	Running lights
6 - 54	Brake light



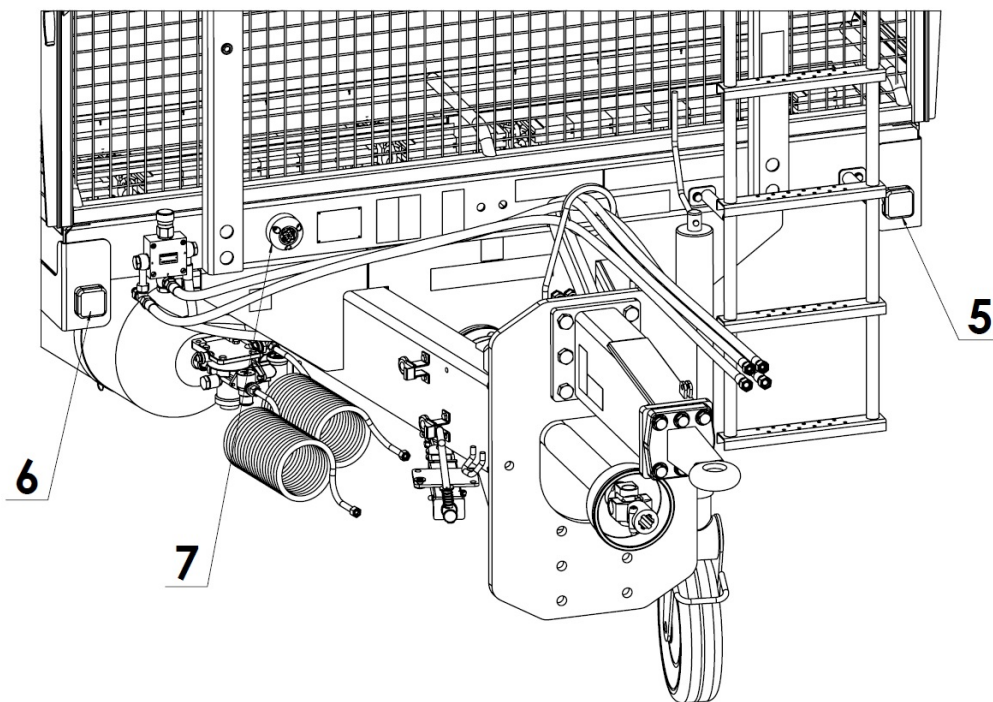
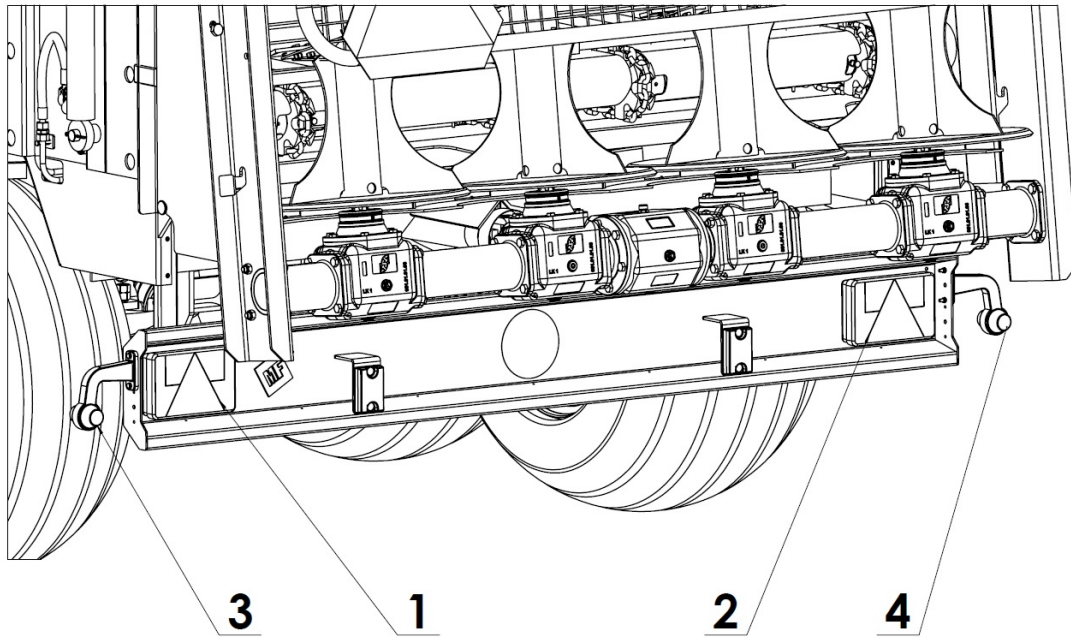

**Figure 14** Arrangement of the electrical system components:  
 1 - rear left lamp cluster, 2 - rear right lamp cluster, 3 - left marker light, 4 - right marker light, 5 - front left running light, 6 - front right running light, 7 - 7-pin connection socket

## 4. Instructions for Use

### 4.1 Preparing the Machine for Operation

#### 4.1.1 Checking the Spreader after Delivery

The Spreader is delivered to the User completely assembled and does not require any additional assembly. However, this does not exempt the User from the obligation to check the machine before purchasing and commissioning it.

Before coupling the Spreader, make sure that the tractor is suitable for this purpose. The Spreader can only be coupled with a tractor which meets the requirements listed in Table 1.



CAUTION

#### CAUTION!

Before coupling and putting the Spreader into operation for the first time, it is mandatory to learn the design of the Spreader, the layout of individual components, as well as read and follow the contents of this Instruction Manual and the PTO shaft Instruction Manual. Observe the guidelines provided in the instructions supplied with the machine.

The Spreader can only be coupled to a farm tractor, which features a hitch suitable for connecting to single-axle trailers, as well as suitable connection sockets for the braking, hydraulic, and electrical systems.

The oil applied in the external hydraulic system of the tractor must be compatible or miscible with the oil used in the hydraulic oil of the Spreader.

Before connecting the machine to the tractor, the operator must verify the technical condition of the Spreader and prepare it for the initial start-up. To this end, verify the following:

- the completeness of the machine;
- the condition of the paint coating and mechanical damage to individual components;
- the technical condition of the protective guards and the correctness of their assembly;
- the technical condition of the hydraulic and pneumatic conduits;
- the technical condition of the PTO shafts and their guards;
- the hydraulic system and gears for leaks.

#### 4.1.2 Preparing the Spreader for the initial start-up

Before starting the trailer for the first time, check the following:

- lubricating points and, if necessary, lubricate the components;
- the correct tightening of screwed connections (road wheels, drawbar, components of the spreading adapter);
- oil level in the gears of the adapter and the floor conveyor;
- the tensioning the chains of the floor conveyor;

- Make sure that the PTO shaft transmitting power from the tractor has a sufficient length in all possible configurations of the tractor in relation to the machine, when coupled (Figure 15);
- whether the speed of the tractor's PTO shaft matches the required rotational speed of the Spreader drive.



CAUTION

**CAUTION!**

Under normal operating conditions, the tubular profiles of the PTO shaft should work overlapped by 1/2 of the shaft's length, and by 1/3 of the shaft's length, under extreme operating conditions.

Observe the instructions of the shaft Manufacturer, when fitting the PTO shaft.

If fitted incorrectly, the PTO shaft transmitting power from the tractor can be damaged or destroyed, when driving on an uneven terrain and when cornering.



The PTO shaft can only be adapted to the one type of the tractor which works with the Spreader. If the machine is coupled with a different tractor, re-check the correctness of coupling the PTO shaft.

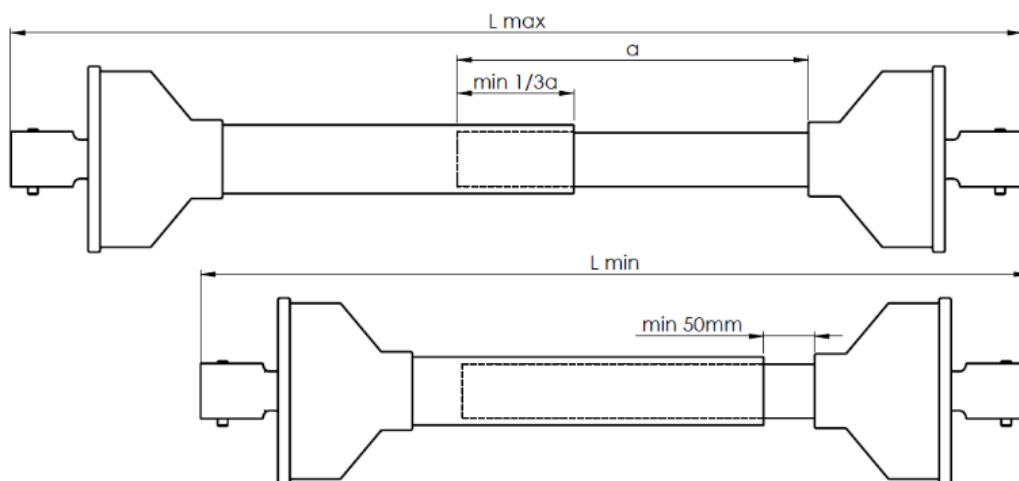
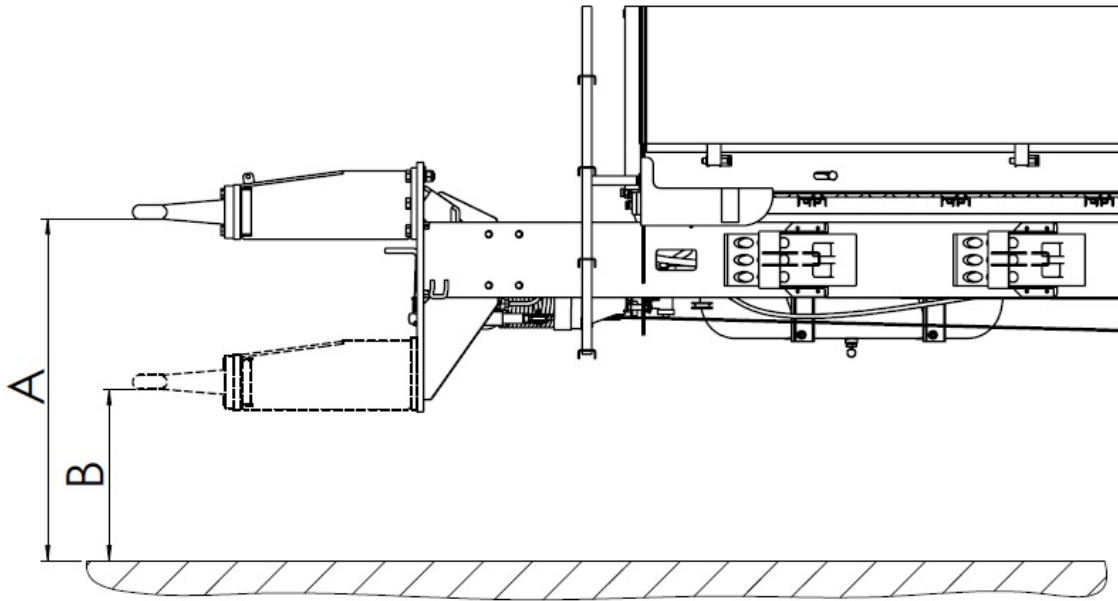

**Figure 15** Adjusting the length of the PTO shaft when the Spreader is coupled with the tractor

#### 4.1.3 Changing the Position of the Hitch

The pre-assembled Spreader is designed to be coupled to the tractor's lower hitch. The hitch can be repositioned to adapt it to coupling with the lower hitch of a tractor - see Figure 16. This is done by undoing the screws securing the hitch and moving the hitch along the holes to a the lower position. Changing the position of the hitch should only be carried out, if it is not possible to couple it with the upper hitch of the tractor. See Table 8 for the estimated heights of the position of the drawbar eye in relation to the ground. Tighten the M20 10.9 screws fixing the hitch to 468.9Nm, while the M16 10.9 screws fixing the hitch eye to 237.4Nm.

See Table 8 for the estimated height ranges between the drawbar eye and the ground.



**Figure 16** Position of the drawbar in relation to the ground

**Table 8** The estimated range of heights of the drawbar in relation to the ground

Wheel sizes \ Position of the drawbar eye	Spreader N280 (6t)		Spreader N280/1 (8t), N280/2 (10t)	
	A [mm]	B [mm]	B [mm]	B [mm]
400/60-15.5"	905	415	---	---
500/50-17"	920	430	920	430

#### 4.1.4 Initial start-up

If the preparatory work has been completed and the Spreader is in a good working order, couple it with the tractor. After starting the tractor, check the function of each individual system, when parked and unladen. Follow the sequence of actions discussed below to start the machine for the first time:

- 1) Couple the Spreader with a compatible tractor hitch.
- 2) Connect the power take-off shaft and secure it correctly.
- 3) Connect the braking, hydraulic, and electrical conduits/lines.
- 4) Lift the support foot to its uppermost position.
- 5) Check the proper operation of the lighting system.
- 6) Release the parking brake of the Spreader.
- 7) Start the tractor.
- 8) Check the operation of the main brake, as soon as starting to drive.
- 9) Check the operation of the floor conveyor:
  - set the feed rate in the range from "3" to "10" on the flow controller mounted on the right panel of the hopper,
  - use the appropriate distributor lever of the tractor to start the floor conveyor,

- look through the openings in the front shields to observe the movement of the conveyor bars and make sure that they move in the right direction; shift the distributor lever in the tractor to change the direction of movement of the conveyor.
- 10) Check the correctness of opening of the slide gate in the hopper and the adapter cover:
    - Use the appropriate distributor lever in the tractor to open and close the slide gate in the hopper.
  - 11) Start the PTO shaft drive at low engine speed (start the drive of the adapter rotors).
  - 12) Allow the adapter run at low engine speed for a few minutes and check, whether:
    - there is no knocking sound or any other disturbing sounds coming from the drive system and the adapter,
    - the adapter rotors rotate smoothly without jamming.
  - 13) Switch off the PTO shaft drive and the tractor engine, and uncouple the Spreader from the tractor.



CAUTION

**CAUTION!**

Do not operate the PTO shaft at other rotational speeds than the ones specified in Table 3.

If all preparatory work has been completed successfully, the Spreader can be approved for operation. If any malfunction or faults of individual systems are found during the initial start-up, report them to the point of sale or directly to the Manufacturer to have the problem solved or to carry out repairs.



CAUTION

**CAUTION!**

Failure to follow the recommendations in the Instruction Manual or starting up the machine incorrectly can result in damage.

Ensure that there are no reservations as to the technical condition of the Spreader, before it is put into operation.

## 4.2 Coupling and Decoupling of the Spreader

The machine can only be coupled with a farming tractor in good working order, fitted with all the necessary connections (braking, pneumatic, hydraulic, and electrical connections), and a hitch meeting the requirements of the Manufacturer of the Spreader.

Before coupling the Spreader to the tractor, make sure that the Spreader has been secured with the parking brake.



CAUTION

**CAUTION!**

Before coupling the machine, check the technical condition of the hitching mechanisms of the tractor and the Spreader, as well as the connecting elements of the braking, hydraulic, and electrical systems.



CAUTION

**CAUTION!**

Exercise extra care, when coupling the Spreader.

The hydraulic oils applied in the tractor and the Spreader must be miscible.

After coupling the Spreader to the tractor, secure the braking, hydraulic, and electrical lines in such a way that they will not break, wear, bend, crush, or accidentally disconnect, while driving.

For travel and operation, raise the support foot to its uppermost position, and close the hydraulic valve retaining the foot.

### **Coupling the Spreader**

To couple the Spreader, follow the sequence of actions below:

- 1) Use the parking brake to immobilise the Spreader and put the protective chocks under the wheels.
- 2) Align the position of the tractor straight in front of the Spreader's hitch.
- 3) Set the drawbar eye to the height that enables coupling the machine:
  - turn the crank of the support foot in the correct direction, until the drawbar eye is at the required height.
- 4) reverse the tractor and couple the Spreader to the tractor's hitch. Check the securing pin of the coupling preventing the machine against accidental disconnecting:
  - if the tractor is fitted with an automatic hitch, make sure that the coupling is completed and the drawbar eye is secured.



DANGER

**DANGER!**

It is not allowed for bystanders to stand between the Spreader and the tractor, during the coupling procedure.

When coupling the machine, the operator of the tractor should exercise particular caution and make sure that no unauthorized persons are in the danger zone.

When connecting the hydraulic lines, make sure that the hydraulic systems of the tractor and Spreader are not pressurised.

- 5) Use the distributor lever to lift the support foot to its uppermost position.
- 6) Activate the parking brake of the tractor, switch off the tractor's engine, remove the key from the ignition switch, and secure the tractor against unauthorised access.

- 7) Connect the conduits of the 2-line pneumatic braking system; connect the yellow pneumatic conduit to the yellow pneumatic socket in the tractor and the red pneumatic conduit to the red pneumatic socket in the tractor:
  - if the Spreader is fitted with hydraulic brakes, connect the hydraulic conduit of the Spreader's brakes to the plug of the hydraulic braking system in the tractor. Then, connect the activating chain of the emergency braking valve to the permanent element on the tractor;
  - if the Spreader is equipped with hydraulic-pneumatic brakes, connect the pneumatic or hydraulic braking system, respectively, depending on the type of the braking control mechanism installed in a particular tractor.
- 8) Connect the hydraulic conduits of the driving system of the floor conveyor.
- 9) Connect the hydraulic conduits of the slide gate system.
- 10) Install the PTO shaft and secure the shields against rotating.
- 11) Release the parking brake of the Spreader.

### Uncoupling the Spreader

To uncouple the Spreader, follow the sequence of actions below:

- 1) Support the Spreader on the support foot in such a way that the position of the drawbar eye makes it possible to uncouple the tractor safely:
  - turn the crank in the correct direction, until the drawbar eye is at the required height,
- 2) Activate the parking brake of the tractor, switch off the tractor's engine, remove the key from the ignition switch, and secure the tractor against unauthorised access.
- 3) Stop the Spreader using the parking brake and place the protective chocks under the wheels.
- 4) Close the locking valve of the hydraulic support foot (located directly at the drawbar).
- 5) Release pressure in each of the hydraulic systems in the tractor.
- 6) Uncouple the hydraulic hoses of the floor conveyor, slide gate, adapter covers of the support foot, secure them with covers, and hang the plugs in the holder located on the holder for conduits.
- 7) Disconnect the conduits of the braking system.
- 8) Disconnect the power take-off shaft and secure it correctly.
- 9) Uncouple the Spreader's hitch from the tractor hitch and move the tractor away.



CAUTION

#### CAUTION!

Exercise extra care, when uncoupling the Spreader from the tractor.

It is not allowed to uncouple the Spreader from the tractor, if it is loaded and supported on the foot.

It is not allowed to disassemble the support foot and support the machine with makeshift elements.

### 4.3 Loading the hopper

Before loading, drive and park the correctly coupled tractor and Spreader on a stable, horizontal ground. Park both machines in a straight-ahead position and secure them both with the parking brake.

Before loading, make sure that there are no persons, objects (stones, pieces of wood, etc.) inside the hopper, whether the slide gate is fully lowered, and the floor conveyor is not damaged.



**CAUTION!**  
When transporting and operating a laden Spreader, the front-axle load of the tractor must equal at least 20% of the tractor weight.

**CAUTION**

Use suitable loaders, front loaders, or conveyors for loading. Start loading manure at the rear of the hopper, layer by layer. When loading, empty the bucket smoothly from the lowest possible height. Do not try compacting the manure on purpose.

Ensure an even distribution of the load to achieve the optimum spreading conditions. Due to the differences in the density of the spreading material, using the entire hopper capacity can result in the exceeding of the permissible design load bearing capacity of the Spreader. Therefore, observe the permissible gross weight. See Table 9 for the estimated densities of selected materials.

**Table 9** The estimated densities of selected materials

Type of Material	Density [kg/m <sup>3</sup> ]
Fermented manure	700-800
Composted manure	800-950
Fresh manure	700-750
Compost	950-1100
Peat	330-650
Agricultural lime	2700-3400

Regardless of the type of transported material, the User is obliged to secure it in such a way that it cannot move freely and pollute the road. If this requirement cannot be met, do not transport such materials.



**CAUTION!**  
It is forbidden to exceed the gross weight.  
Unevenly distributed load causes uneven spreading of the material in the field.

**CAUTION**



### 4.3.1 Loading and Spreading of Lime

It is allowed to spread loose agricultural lime and its derivatives. Failure to observe the following guidance can result in damage to the Spreader.

The general recommendations for spreading agricultural lime:

- 1) The maximum weight of loaded lime must not exceed 3t for N280 Spreaders (0.3m from the floor); 3.5t for N280/1 Spreaders (0.35m from the floor); 4t for N280/2 Spreaders (0.4m from the floor), i.e. 1/3 of the height of the hopper.
- 2) Spread lime immediately after loading, as it can set permanently on the floor of the Spreader after a long period of time, which could stop the movement of chains and bars.
- 3) Once loaded with lime, the Spreader cannot have any contact with moisture, and it is not allowed to start the drive of the floor conveyor during precipitation of any kind (unload it manually, if water gets inside the Spreader loaded with lime).
- 4) Due to its compaction properties, lime can accumulate in chain links and sprockets. Therefore, regularly inspect the technical condition of all components of the floor conveyor (preferably, after each pass).
- 5) Thoroughly clean the chains, feeder bars, and sprockets, after each spreading of lime (it is recommended to use a pressure washer with clean water or appropriate agents). Washing and drying must be carried out at temperatures above zero.
- 6) Degrease all greasy or oily surfaces with extraction naphtha or degreasing agents, and then wash them with clean water mixed with a detergent.

Manure Spreaders are not typically designed for spreading lime and its derivatives. When spreading lime with Spreaders, it is not possible to achieve the optimum spreading parameters, when compared to lime spreading using machines specifically designed for that purpose.



CAUTION

#### CAUTION!

Strictly adhere to the recommendations regarding lime spreading.

Failure to adhere to the guidelines regarding lime spreading with the Spreader can result in damage to the machine.

When spreading lime or lime-derivative fertilisers, use suitable protective clothing and PPE, and observe the general regulations for fertiliser application.

## 4.4 Adjusting Fertiliser Doses and Manure Spreading

### 4.4.1 Adjusting Fertiliser Doses

Dosage of spreading material over a certain area of the field depends on the following factors:

- 1) The speed of the floor conveyor.
- 2) The driving speed.
- 3) The loading height of the hopper.
- 4) The effective spreading width, depending on the type of spreading material.

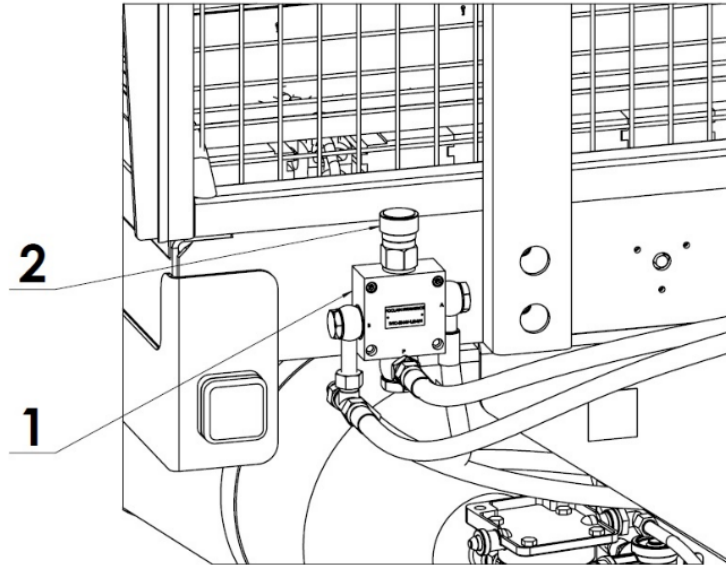

**Figure 17** Adjusting the Speed of the Floor Conveyor:  
1 - oil flow regulator, 2 - regulator knob

Select the feeding speed of the floor conveyor by trial and adjust it with a knob (2) on the flow controller (1) located on the front beam of the hopper – see Figure 17.

#### **Adjusting the Speed of the Floor Conveyor:**

- reducing the speed of the floor conveyor: turn the knob of the controller clockwise towards “0”.
- To increase the speed of the floor conveyor: turn the knob of the controller anticlockwise towards “10”.



Low driving speeds and high speeds of feeding the load result in high dosages of fertilisation.  
High driving speeds and low speeds of feeding the load result in low dosages of fertilisation.

**Table 10** Dosage of manure (the density of 950kg/m<sup>3</sup>), depending on the feeding speed of the floor conveyor and the actual working speed.

Setting No.	Conveyor Capacity [kg/s]	The Working Speed of the Spreader [km/h]						
		4	5	6	7	8	9	10
		Dose of manure [t/ha]						
2	4.4	4.8	3.6	3.2	2.9	2.6	2.2	1.8
3	5.4	6.1	4.9	4.1	3.5	3.0	2.7	2.4
4	12.1	13.6	10.9	9.1	7.8	6.8	6.1	5.4
5	21.7	24.4	19.5	16.3	13.9	12.2	10.9	9.8
6	32.3	32.3	36.3	29.1	24.2	20.8	18.2	16.2
7	42.1	47.4	37.9	31.6	27.1	23.7	21.1	18.9
8	54.4	61.2	49.0	40.8	35.0	30.6	27.2	24.5
9	64.7	72.8	58.2	48.5	41.6	36.4	32.4	29.1
10	83.8	94.3	75.4	62.9	53.9	47.1	41.9	37.7

#### 4.4.2 Spreading of manure

Before starting to spread manure, re-check the condition of the hydraulic connections and safety guards.



**DANGER**

#### **DANGER!**

Operating the Spreader with safety guards removed or with damaged PTO shaft poses a direct risk to the life and health of the operators.

It is not allowed for bystanders or animals to be present in the spreading zone.

Keep a safe distance from power lines, especially when working with the slide gate of the hopper raised.

Do not operate the PTO shaft at other rotational speeds than the those specified in Table 3. Using different PTO speeds can damage the adapter or its drive.

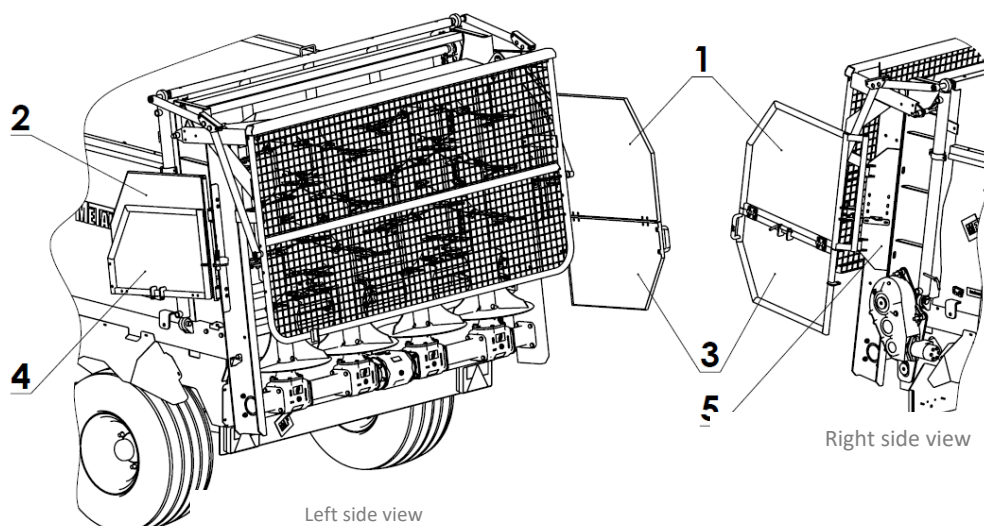

**Figure 18** Spread limiting screens in the “closed” and “open” positions:

- 1 - top right wing of the screen, 2 - top left wing of the screen, 3 - bottom right wing of the screen, 4 - bottom left wing of the screen, 5 - set of fixing elements

Adjust the correct working position of the right or left spread-limiting screens (optional accessories) to limit spreading and ensure the accurate fertilising of the field along the boundaries – see Figure 18.

### **The Procedure for Starting Manure Spreading**

- 1) Align the tractor and Spreader unit in a straight-ahead position at the place where fertilisation will start.
- 2) Fold out the right or left spread-limiting screen, if spreading is to be carried out along the perimeter of a field, a water reservoir, a drainage ditch, etc. - or keep a sufficient distance from the areas which should not be fertilised, when spreading.
- 3) Make sure that the PTO shaft of the tractor is adjusted to the correct range of rotational speed.
- 4) Start the PTO shaft at a low engine speed and increase the engine speed, until the adapter rotors have reached the correct speed, and keep it within this range.
- 5) Fully raise the slide gate of the hopper.
- 6) Use the correct distributor lever to start the drive of the floor conveyor, and verify the correct direction of feeding.
- 7) Engage the tractor gear and start working as soon as the sufficient amount of manure has been fed onto the rotors of the adapter.

### **Ending the Spreading Procedure:**

- 1) It is recommended to lower the slide gate of the hopper to the height of the fed material, in the final phase of spreading.
- 2) In order to obtain a uniform dose of spreading material in the final stage of spreading, reduce the travel speed, or use the knob on the flow controller to increase the feeding speed of the floor conveyor.
- 3) Switch off the drive of the floor conveyor, after the hopper has been emptied completely.
- 4) Fully lower the slide gate in the hopper.
- 5) Reduce the rotational speed of the engine and switch off the PTO shaft drive.

- 6) Fold the right or left spread-limiting screen to the transport position, if it was folded out to the working position during spreading. When travelling on public roads, the spread-limiting screens should be folded to the transport position.
- 7) Clean the Spreader after each completion of spreading, if you intend to drive on public roads, in order to avoid surface contamination.



CAUTION

#### CAUTION!

Strictly observe the Spreader starting sequence provided herein. Following any different sequence can damage the Spreader and endanger the health or life of the operators.

When driving on headlands, first switch off the drive of the floor conveyor, and the PTO shaft of the tractor.

The direction of movement of the floor conveyor can only be reversed, if the rotors of the adapter are locked. It is not allowed for the load to come into contact with the front panel of the hopper, when the load is moving forward.

#### 4.4.3 Clogging the Spreading Adapter

When spreading manure, the spreading adapter can get clogged, which stops the rotors of the adapter, resulting from the shearing of the safety pin in the PTO shaft transmitting power from the tractor to the Spreader. If the rotors of the adapter come to a stop during spreading, immediately switch off the drives of both the floor conveyor and the PTO shaft drive in the tractor.

Causes of the adapter's clogging:

- objects such as stones, wood, etc. get into the adapter together with manure,
- the feeding speed of the floor conveyor is too high,
- the rotational speed of the PTO shaft is kept too low,
- inadequate speed of the PTO shaft,
- the load is too dense.

#### Unclogging the spreading adapter:

- 1) Switch off the PTO shaft drive and uncouple the PTO shaft from the tractor.
- 2) Reverse the floor conveyor by switching the distributor lever in the tractor in the direction opposite to the normal working position of the feeder.
  - Perform this action in phases.
  - Reverse the conveyor only as much as required for the load not to press on the rotors of the adapter.
  - It is not permitted to move the conveyor forward, when the load is in contact with the front panel of the hopper.
- 3) Switch off the tractor's engine, activate the parking brake to stop the tractor and the Spreader, remove the key from the ignition switch, and secure the tractor against unauthorised access
- 4) Use suitable tools to remove any objects blocking the rotors of the adapter.
- 5) Install the coupling screw in the PTO shaft and connect it to the tractor.
- 6) Start the tractor's engine and switch on the PTO shaft to clean the rotors of the adapter off any residual material.

## 5. Technical Maintenance

### 5.1 Checking and Adjusting the Tension of the Floor Conveyor Chains

Check the tensioning of the floor conveyor chains during operation daily, especially during the initial period of operation.

Use the adjusting screws on the upper frame rails to tighten the chains of the conveyor – see Figure 19. The adjustment is made by turning the screw (3) to obtain the correct chain tension, but if the tension of one of the chains is different, the settings should be corrected by means of a fastener (7). If the adjustment range of the screw (3) has been exhausted, adjust the wedge support (5) using the screws (10) and the tappet block (4).

To correct the adjustment of tensioners, when the adjustment range of the screw (3) is exhausted, move the tensioner tappet block (4) using the screws (10), and lock the position of the screw with the nut (9).

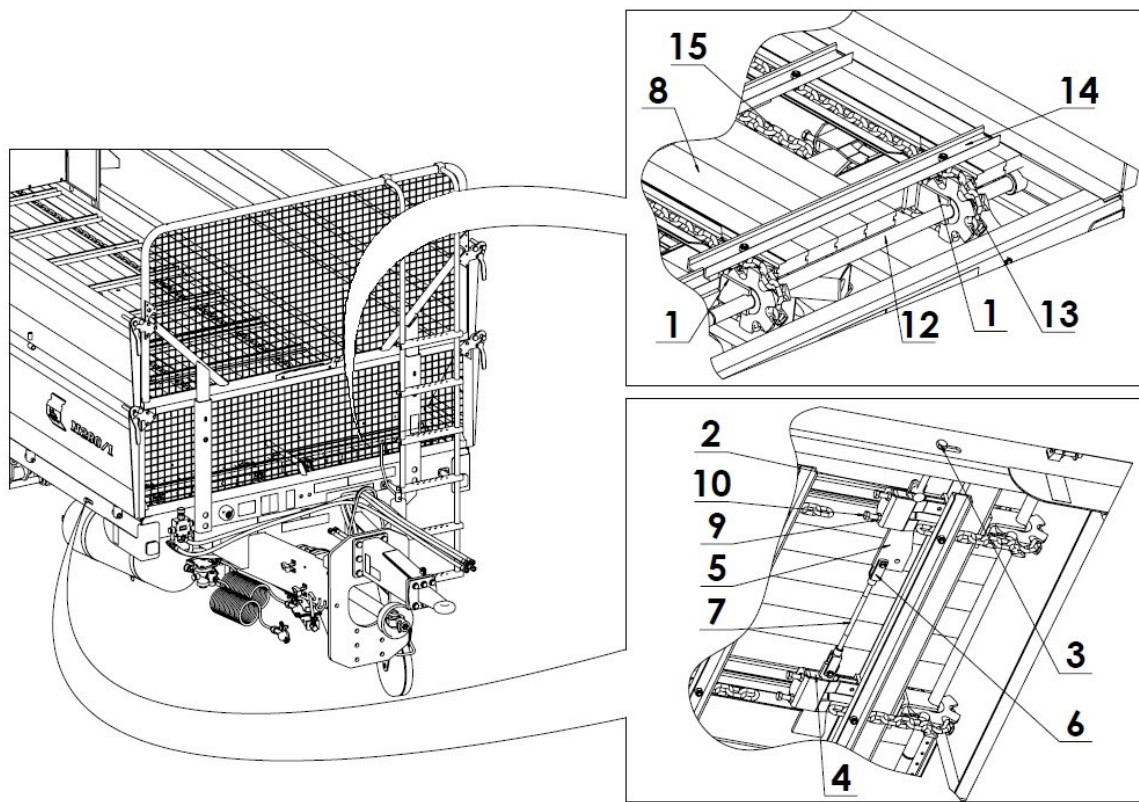

**Figure 19** Tensioning the chains of the floor conveyor:  
1 - adjusting screw, 2-3 - nuts, 4 - bearing unit of the tensioner

If tensioned correctly, the chain can be raised to a height of 40-80mm, when applying a force of 50kg to the chain in the middle of the length of the hopper.

If the entire range of adjusting chain tensioning is used up, it is possible to shorten the chain of the conveyor by removing 2 links of the chain at the point of their connecting. Excessive extending of the chains can result from the incorrect adjustment of their tensioning and clogging of the sprocket wheels of the floor conveyor. Clogging the sprocket wheels is caused by damaged or worn chain sprocket scrapers. Therefore, check them regularly for their working condition and change them, if necessary.

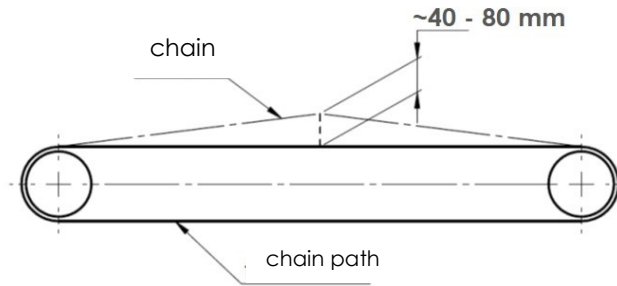

**Figure 20** Checking the tensioning of the chains in the Spreader



CAUTION

**CAUTION!**

All conveyor chains must be tensioned equally.

If too loose, the chains can damage the Spreader and pose a direct risk to bystanders or operators.

## 5.2 Maintaining the Hydraulic System

The hydraulic system of the Spreader must be leak-proof. It is not allowed to operate the Spreader with a leaking hydraulic system. To check the tightness of the system, activate each individual circuit of the hydraulic system several times. If oil leakage is found, seal the connection or change the leaking line.

**Table 11** The specifications of the HL-46 hydraulic oil

No.	Name	Value
1	Viscosity grade as per ISO 34448VG	46
2	Kinematic viscosity	41.4 - 50.6mm <sup>2</sup> /s (40°C)
3	Quality class as per ISO 11158	HL

Each new Spreader has its hydraulic system factory-filled with the HL-46 oil. The oil in the hydraulic system of the tractor should be of the same grade as the oil used in the hydraulic system of the Spreader. It is permitted to mix oils of the same grade, provided that it is approved by the oil Manufacturer. The hydraulic system of the Spreader is not equipped with a filter, which means that the cleanliness of the oil in the system depends on the condition of the filters in the hydraulic system of the tractor. The correct and trouble-free operation of the hydraulic system depends on the cleanliness of the hydraulic oil.

Keep both the hydraulic quick couplings of the Spreader and the hydraulic sockets of the tractor clean. After disconnecting the conduits from the tractor, wipe the plugs of quick couplings with a clean and dry cloth, and then secure them with protective caps.



Change rubber hydraulic conduits every 4 years, regardless of their technical condition, unless a fault has been found earlier.

Change the filters and oil in the hydraulic system of the tractor on a regular basis to ensure reliable and stable operation of the hydraulic system of the Spreader.



CAUTION

**CAUTION!**

The hydraulic system is under high pressure during operations. Check the tightness of the hydraulic system and the technical condition of the conduits on a regular basis, and eliminate any leaks on an ongoing basis.

Use the hydraulic oil recommended by the Manufacturer.

Never mix two different types of oil.

Contaminated oil can cause the failure of hydraulic components.

The oil used in the hydraulic system is not listed as a hazardous substance, but prolonged skin exposure can cause irritation. Use soap and water to wash the skin that has come into contact with oil.

**5.3 Gear maintenance**

The maintenance of the gear of the Spreader involves checking the level of, topping up, and changing the gear oil.

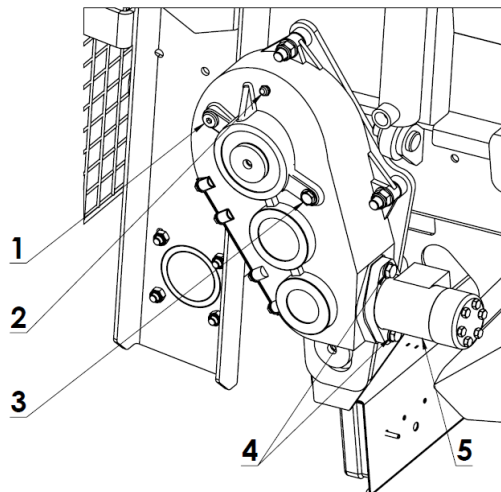

**Figure 21** Oil level control points in the gear of the floor conveyor:

1 - oil filler, 2 - air vent, 3 - oil-level sight glass, 4 - hydraulic motor fixing screws, 5 - hydraulic motor

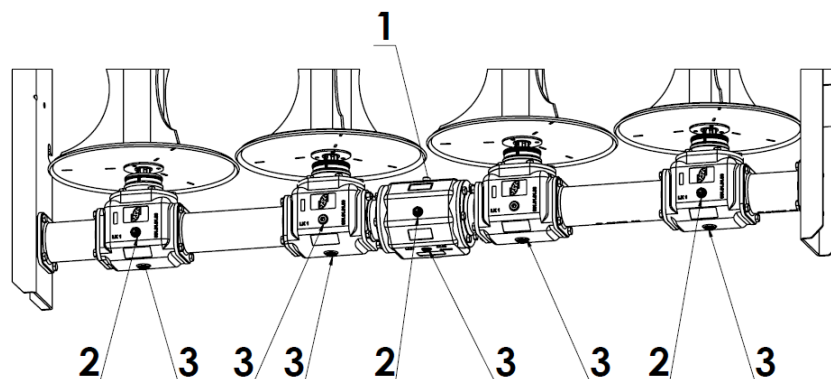

**Figure 22** Oil level control points in the gear of the adapter:

1 - oil filler (vent), 2 - oil-level sight glass, 3 - drain plugs



Change oil at the operating temperature, immediately after work is completed, when the oil is still hot. Carry out the work by driving the Spreader on hardened, level ground. When changing oil, wear suitable protective clothing, tools, and tanks. Store waste oil in appropriately marked containers and dispose of it, in accordance with the applicable regulations.

To drain oil from the gear of the floor conveyor (Figure 21), undo the screws (3) and pull out the hydraulic motor (4). Fill the gears with new oil through the oil filler (1), until oil becomes visible in the sight glass (3). If oil is visible in the middle of the sight glass, its level is correct.

To drain oil from the gear of the adapter (Figure 22), undo the drain plugs (3). Fill the gears with new oil through the oil filler (1), until oil becomes visible in the sight glass (2). If oil is visible in the middle of the sight glass, its level is correct. All the gear housings are interconnected in gear of the adapter, which means that you only need to use the filler plug (1) on the central housing to top up and check the level of oil in the entire unit.



Each time before you start the machine, check the oil level in the gears of the adapter and the floor conveyor, via the sight glass.



Change the oil in the gears of the adapter and the floor conveyor after the first 50 hours of operation, and then every 700 hours of operation.

**Table 12** Quantity of oil in the gear

Name	Type of oil	Volume
The adapter gear	Hipol GL 4 80/W90	12 L
The floor-conveyor gear	Hipol GL 4 80/W90	4.3 L



**DANGER!**  
 When changing oil, use the appropriate personal protective equipment, such as safety clothing, gloves, glasses, and footwear.  
 Avoid contact of oil with the skin.  
 Oil can cause an allergic skin reaction.  
 Oil has harmful long-term effects on aquatic species.

**DANGER**

### 5.4 Lubrication

Proper lubrication is one of the most important factors which determine the efficient operation of each individual unit and the mechanisms of the Spreader.

Complying with the lubrication recommendations of the Manufacturer will significantly reduce the possibility of damage or premature wear and tear of individual parts. Lubrication points are indicated in Figures 23, 24, 25, and 26, while the lubrication schedule in Table 13.

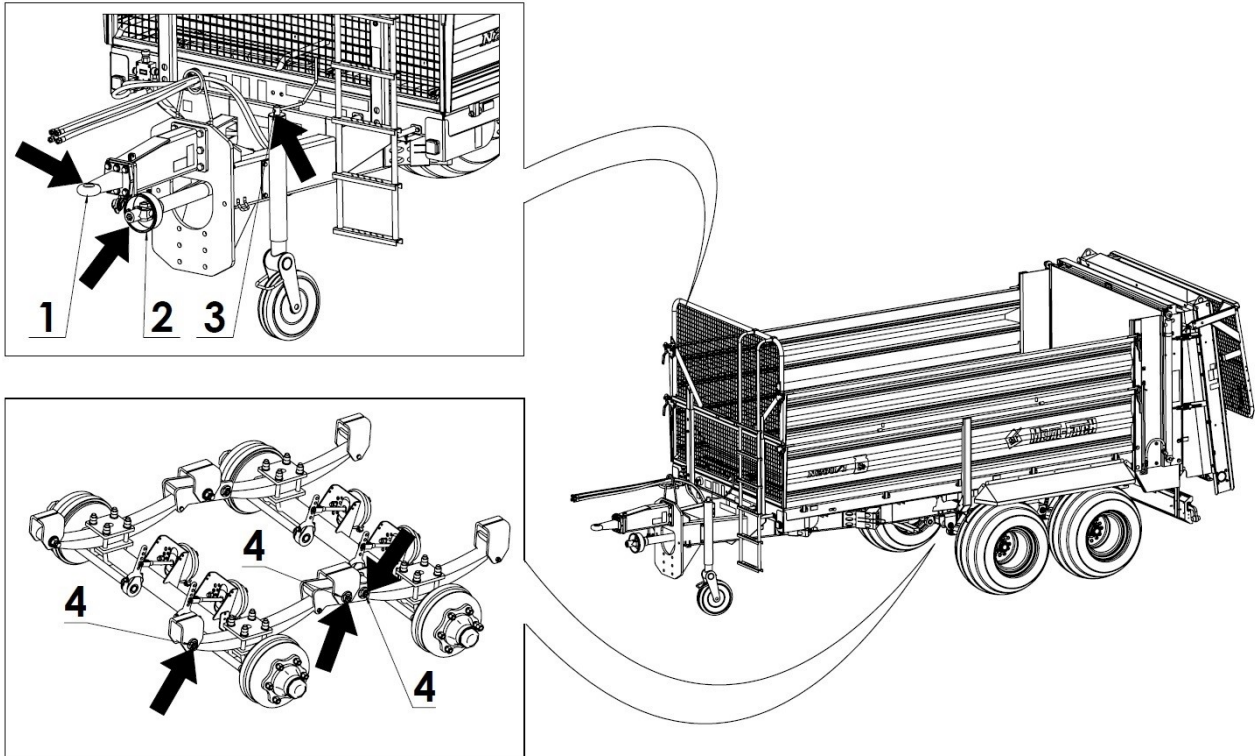

**Figure 23** Lubricating points common to the N280, N280/1, and N280/2 Spreaders

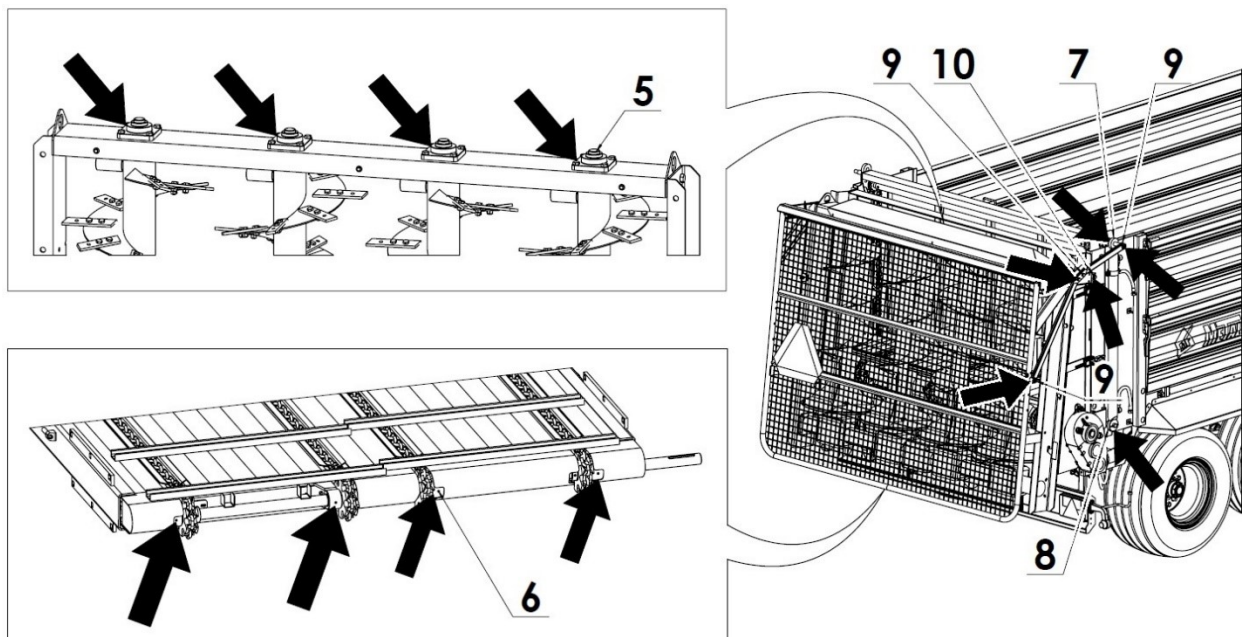

**Figure 24** Lubricating points

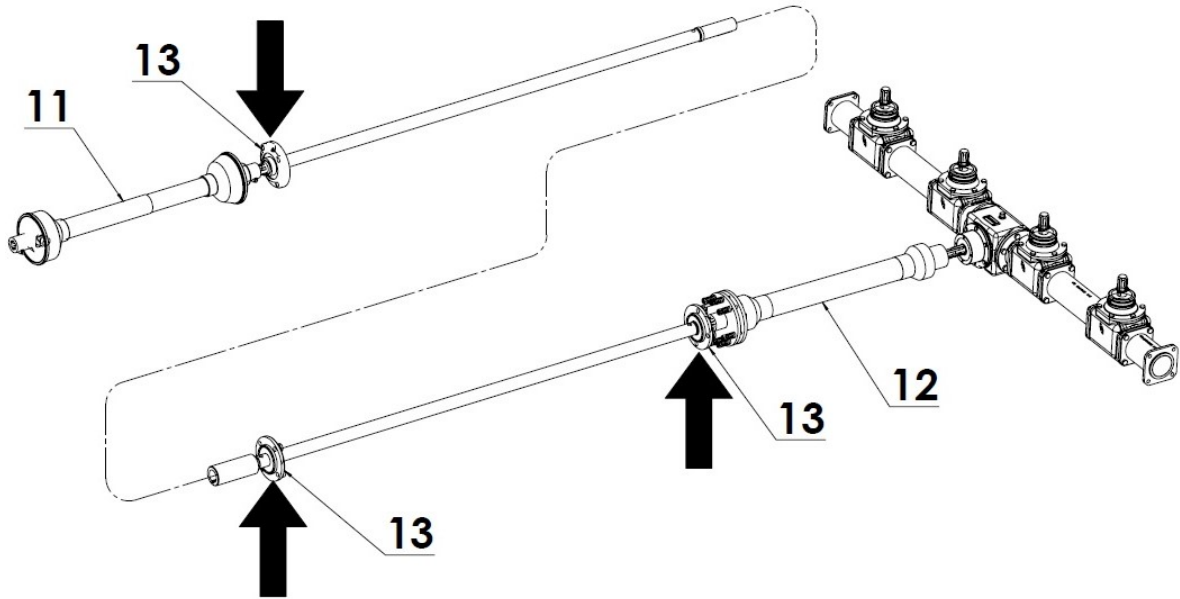

**Figure 25** Lubricating points

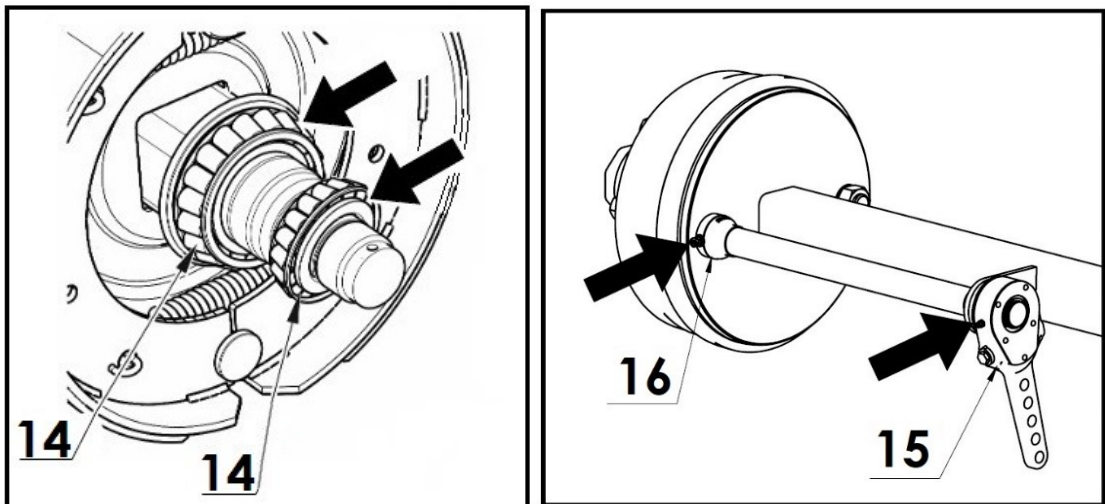

**Figure 26** Lubricating points

**Table 13** The lubrication schedule

No.	Name of mechanism	Number of lubricating points	Grease type	Interval
1.	Drawbar eye	1	ŁT	2D
2.	The splines of the shaft of the drive system	1	ŁT	6M
3.	Support foot	1	ŁT	6M
4.	Suspension spring pins	6	ŁT	24H
5.	Upper bearings of the adapter	4	ŁT	24H
6.	Bearings of the driving shaft of the conveyor	4	ŁT	8H
7.	Plain bearing of the piston rod of the cylinder	2	ŁT	6M
8.	Plain bearing of the cylinder housing	2	ŁT	6M
9.	Drawbar sleeves of the adapter cover	8	OM	6M
10.	Hinges of the adapter cover	2	OM	6M
11.	Front PTO shaft	*	*	*
12.	Rear PTO shaft	*	*	*
13.	Bearings of the drive train of the adapter	3	ŁT	6M
14.	Bearings of the wheel hub	8	ŁT	24M
15.	Lever of the brake expander	4	ŁT	6M
16.	Sleeves of the expander shafts	4	ŁT	6M

\* - Observe the guidelines provided in the Instruction Manual supplied with the PTO shaft

Lubrication interval codes: H - working hour, D - working day, M - month

When lubricating, follow the guidelines below:

- clean the lubricating nipple, before starting to pump grease;
- pump grease, until fresh grease appears in the slots (through which used grease is squeezed out during pumping); after finishing lubrication, leave a little grease on the nipple head.

**Table 14** Lubricants

Codes from Table 10	Description
ŁT	ŁT-42, ŁT-43 General purpose grease
OM	Machine oil

Use a clean cloth to wipe the parts to be lubricated with machine oil, and then apply a small amount of oil to the lubricated parts. Wipe off excess oil.

To lubricate the bearings of the wheel hubs, disassemble the hub, remove used grease, and apply fresh grease. Each time when changing grease, assess the condition of the bearings and change them, if necessary. After mounting the hub, adjust the bearing play.



CAUTION

**CAUTION!**

It is not allowed to drive the Spreader without hub caps. Dirt entering wheel bearings will damage them irreparably.

## 5.5 Maintaining the Pneumatic System

Have the pneumatic braking system components repaired, changed, and regenerated by professional workshops having all appropriate qualifications and tools to perform this type of work.

Maintaining the pneumatic system carried out by the User is narrowed down to:

1. Checking the air-tightness of the system and its visual inspection
2. Cleaning the air filters.
3. Draining the air tank and cleaning the drain valve.
4. Changing the flexible connection conduits.
5. Cleaning and maintaining the connections of pneumatic conduits.



CAUTION

**CAUTION!**

It is not allowed to operate the Spreader, if the braking system is non-operational.

### 5.5.1 Checking the air-tightness and visual inspection of the pneumatic braking system



Checking air-tightness and visual inspection of the system:

- at start-up,
- after the first 1,000km,
- each time system components are repaired or changed annually.

Checking the air-tightness of the pneumatic system:

- Couple the tractor with the Spreader,
- use the parking brake to immobilise the tractor and the Spreader, and put chocks under the wheel of the Spreader,
- start the tractor's engine to supply air to the braking system of the Spreader,
- switch off the tractor's engine,
- check the air-tightness of the pneumatic components after releasing the brake pedal in the tractor,
- check the air-tightness of the pneumatic components, when the brake pedal in the tractor is pressed (it is required to have another person to assist you).

If the system is leaky, air will escape through points of damage producing a distinctive hissing sound. Minor leaks can be detected by applying a layer of foaming agent to the inspected parts (washing-up liquid or soap).

Change the damaged parts or have them repaired. Eliminate any leaks in the joints by tightening the joint or changing the fitting or sealing.

When checking air-tightness of the system, carry out a simultaneous visual inspection of the pneumatic braking system. Pay particular attention to the condition of the pneumatic conduits, the manner of their fastening, and the cleanliness and completeness of the components. Conduits must not show any signs of wearing, permanent deformation, partial splitting, or bending. It is not allowed for the system's components to be contaminated with oil and grease.



CAUTION

**CAUTION!**

Have the pneumatic system components repaired, changed, and regenerated by professional workshops only.

### 5.5.2 Cleaning air filters



DANGER

**DANGER!**

Before dismantling the filters, reduce the pressure in the braking system of the Spreader.

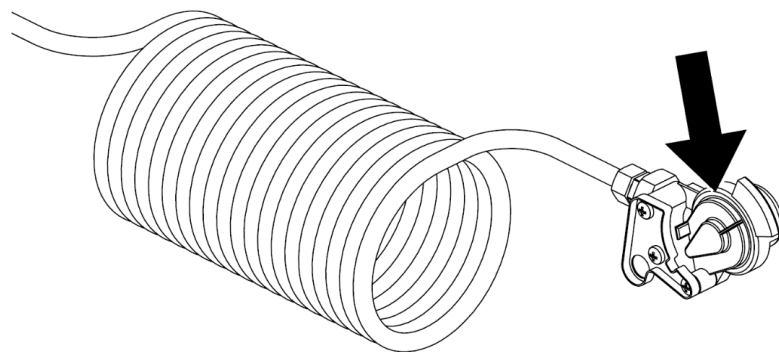

**Figure 27** Haldex air filters for the braking system

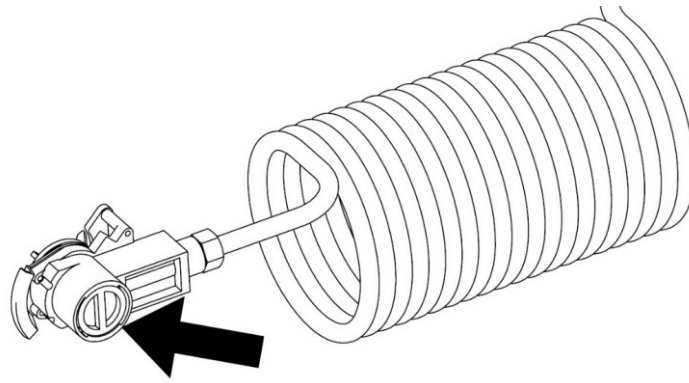

**Figure 28** Knorr-Bremse air filters for the braking system

Clean the air-filter elements, according to their operating conditions, but at least every 6 months. The filters located in the fittings of pneumatic conduits - see Figures 27 & 28. The air filter elements are reusable and it is not required to change them, unless damaged.

### 5.5.3 Draining the air tank

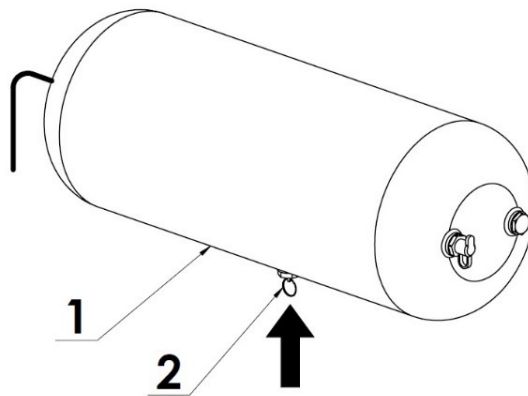

**Figure 29** Draining the air tank:  
1 - air tank, 2 - drain valve



Drain the air tank, after every 7 days of use.

Draining the air tank:

- Pull the stem of the drain valve (2) to let water escape (compressed air will make water escape outside),
- release the stem of the drain valve (the valve will close automatically and cut off the airflow).

If the drain valve is leaking, it must be dismantled and cleaned, or changed, if necessary.

### 5.5.4 Changing the flexible connection conduits

Change all flexible connection conduits every 5 years, unless damage (permanent deformation, wearing, or cutting) has been found earlier.

To change the conduits, do the following:

- purge the system completely,
- unscrew the pneumatic fittings from the conduits,
- unscrew the flexible conduits from the brake valve,
- fit new conduits,
- check the air-tightness of any new connections.

### 5.5.5 Cleaning and maintaining the connections of pneumatic conduits



DANGER

**DANGER!**

Faulty, damaged, or dirty connections of the pneumatic conduits can cause malfunctions of the braking system.

If the connections of pneumatic conduits show any signs of damage, change them for new ones and fully efficient parts. If exposed to oils, petrol, greases, etc., gaskets in the connections can be damaged or age prematurely.

If the Spreader is uncoupled from the tractor, the connections must always be protected with caps and placed in the appropriate holders. It is recommended to preserve the gaskets in the connections with a suitable agent, e.g. silicone spray for rubber parts, after the season is over.

Before each coupling of the machine, check the technical condition of the pneumatic connections in the Spreader and the tractor. Keeping the connections clean extends their service life and ensures the correct operation of the entire braking system.



Always check the technical condition of the pneumatic connections, before coupling the Spreader with the tractor.

## 5.6 Maintaining the driving axle and brakes

### 5.6.1 Maintaining the driving axle

It is recommended to check the bearings of the driving axle for play - see Figure 30. Carry out this inspection on a newly purchased machine, after the first 100km. Then, after driving about 1,500-2,000km, carry out the same inspection again and adjust, if necessary.



To adjust bearing play, do the following:

1. couple the Spreader with the tractor and engage the parking brake in the tractor.
2. Lift one side of the Spreader, so that the wheel does not touch the ground, and secure it against falling.
3. If the wheel shows excessive play, remove the hub cap and the securing pin to prevent the castellated nut from unscrewing.
4. Turn the wheel while simultaneously tightening the castellated nut, until the wheel has stopped completely.
5. Loosen the nut by  $1/6 \div 1/3$  of a turn, until the nearest pin groove overlaps with the hole on the hub spigot.
6. Secure the nut with a new pin, replace, and fasten the hub cap.

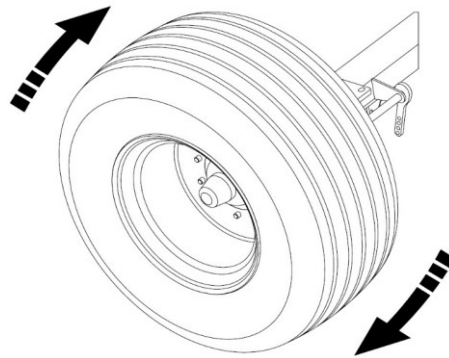

**Figure 30** Checking wheel bearing play

If bearing play is adjusted correctly, the wheel should rotate freely, without jamming or evident resistance (other than the rubbing of the brake shoes against the drum). It is completely normal to experience a slight rubbing of the brake shoes against the drum, particularly in a new trailer or after changing brake shoes for new ones. Drive a few kilometres to finally check the correctness of the bearing-play adjustment, by checking the degree to which the wheel hubs have heated up. In addition to the incorrect adjustment of the bearing play, considerable resistance during wheel rotation and heating of the hubs can be caused by impurities present in grease, or damaged bearings. The afore-mentioned symptoms make it necessary to disassemble the wheel hub to eliminate the malfunction.

### 5.6.2 Maintaining the brakes

After purchasing the Spreader, the User must carry out a general inspection of the braking system on the driving axle, and then repeat it periodically.

Have brake components repaired, changed, and regenerated by professional workshops with all the appropriate and tools to perform this type of work.

The User is responsible for carrying out the following maintenance of the driving axle brake:

- functional checks of the brakes,
- inspections of the brake-linings for wear,
- adjusting the service brake,
- functional check of the parking brake,
- changing the parking-brake cable and adjusting its tension.

**Functional checks of the brakes:**

- couple the Spreader with the tractor and place chocks under the tractor wheels,
- check the manner of fastening the pneumatic cylinder and its forks on the brake lever arm,
- check the axle brake components (pins, cotter pins, nuts, etc.) for completeness,
- activate and release the main brake, and repeat the same with the parking brake (the action of the brakes should be smooth and they should retract without resistance or jamming),
- check the stroke of the cylinder piston rod,
- check the pneumatic cylinders for air-tightness,
- carry out a test run, when unladen, by activating the main brake several times to check its functioning.

**Inspections of the brake linings for wear**

Look through the inspection windows in the brake drum cover to check the brake linings for wear - see Figure 31. Change brake shoes, when the thickness of brake lining has exceeded the minimum value specified by the Manufacturer.

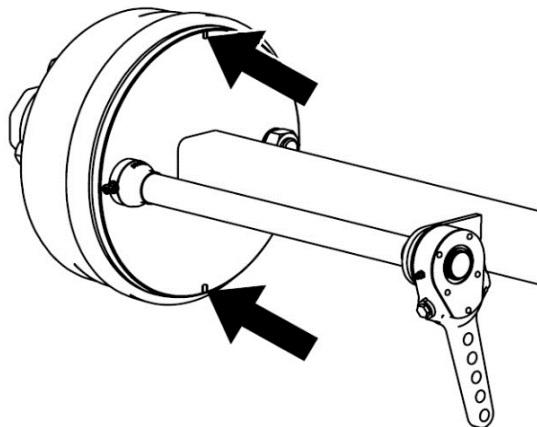

**Figure 31** Inspections of the brake linings for wear



The minimum thickness of brake lining is 5mm.



Inspection of brake lining for wear:

- every 3 months of operation,
- if the stroke of the cylinder piston rod takes significantly longer than normal,
- or if any strange noises are coming from around the brake drum.

### Adjusting the service brake

As brake linings wear, the working stroke of the pneumatic cylinder piston rod increases. Excessive stroke can reduce the effectiveness of braking. Therefore, check and adjust, if necessary, the working stroke of the brake to keep it within the specified operating range. If the brake is adjusted correctly, the angle between the piston rod and the expander lever will be 90° in the braking position - see Figure 32.

To check the functioning of the brake, measure the stroke length of the piston rod in each pneumatic cylinder. If stroke of the piston rod is longer than the maximum value (45mm), the system must be adjusted.

Adjust the stroke of the cylinder piston rod and the angle of the expander lever, by correct setting of the cylinder forks (3) and adjusting the stroke with the adjusting screw (7). Carry out this adjustment for both the cylinder and the expander lever, maintaining the same set values.



The correct stroke of the piston rod should be within the range 25-45mm.

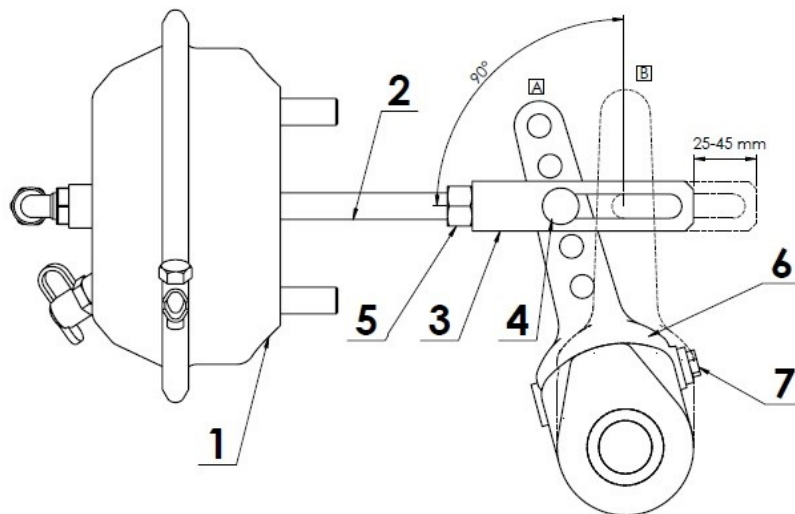

**Figure 32** Adjustment of the parking brake

1 - pneumatic cylinder, 2 - cylinder piston rod, 3 - cylinder forks, 4 - fork pin, 5 - fork lock nut, 6 - expander lever, 7 - adjusting screw:

(A) The lever position when releasing the brake, (B) The lever position when activating the brake



Checking the technical condition of the brake:

- after the first 100km,
- every 6 months,
- after repairing the braking system,
- if the wheels of the Spreader brake non-uniformly.

**CAUTION****CAUTION!**

Improperly adjusted brakes can cause the brake shoes to rub against the drum, which could result in the accelerated wearing of the brake linings and/or the overheating of the brake.

**CAUTION****CAUTION!**

The mounting positions of the pneumatic brake cylinder in the holes of the bracket and of the fork pin of the cylinder in the holes of the expander lever are defined by the Manufacturer and it is not allowed to change them.

**Adjusting the parking brake**

The correct functioning of the parking brake depends on the effectiveness of the driving axle brakes and the correct tensioning of the brake cables.



Check and/or adjust the parking brake:

- every 12 months,
- if required.

Adjust the cable of the hand-brake, if:

- the cable is stretched,
- the cable is damaged,
- the cable clamps are loose,
- the driving axle brake has been adjusted,
- after repairing the mechanism of the driving axle brake,
- after repairing the mechanism of the parking brake.

If the parking brake requires adjusting, make sure that the brake on the driving axle is adjusted correctly and works efficiently.

Adjust the tension of the parking brake cable by its pre-tensioning, which consists in setting the correct length of the loops at its ends. Carry out this adjustment, when the brake of the driving axle is released, and the crank mechanism of the parking brake is fully loosened.

**5.6.3 Tyre Maintenance, Disassembly of the Wheels**

Secure the machine with the parking brake and the wheels with chocks, when maintaining the tyres. Changing the wheel is only permitted, if the hopper is empty. Use suitable tools to repair the wheels. The person carrying out the repairs should be trained in such operations, as maintaining and repairing of tyres involves some risk. It is recommended to check the tightness of the nuts, before the initial start-up, after the first laden drive, and then after each intensive use of the machine, after every 100 kilometres. Repeat these inspection activities after each disassembling of the wheels.

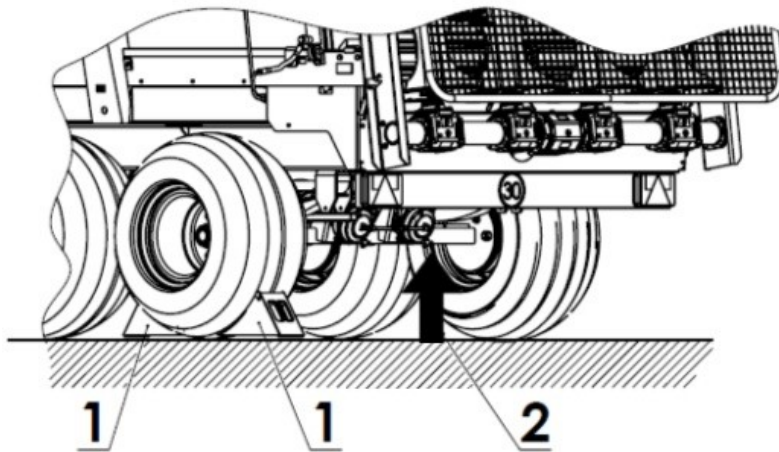

**Figure 33** Jacking points:  
1 - chocks, 2 - jack

If it is necessary to disassemble the wheel, observe the jacking points (2) under the axle. See Figure 33 for the jacking points. Place the protective chocks (1) under one wheel only.



Regularly check the air pressure. Maintain the recommended air pressure. The correct pressure value is indicated on the tyre or as a sticker on the Spreader.



CAUTION

**CAUTION!**

Inspect the tightness of the wheel nuts on a regular basis.  
M18x1.5 = 270Nm, M20x1.5 = 350Nm, M22x1.5 = 475Nm.

- Regularly check and maintain the correct tyre pressure, as recommended in the Instruction Manual and/or the information provided on the tyre.
- Do not exceed the permissible load capacity of the tyres, according to the Instruction Manual and/or information provided on the tyre.
- Do not exceed the permissible speed of the Spreader, according to the Instruction Manual and/or information provided on the tyre.
- Secure tyre valves with protective caps.
- If work continues for the whole day, regularly check the temperature of the tyres and, if they heat up, take 30-minute breaks to cool them down.
- Avoid driving on excessively bumpy terrain, making random manoeuvres, and high speeds, when cornering.
- Regularly check the condition of the tyres and change them if split or damaged.



CAUTION

**CAUTION!**

Do not exceed the permitted transport speed, working speed, and load capacity of the Spreader.

## 5.7 Maintaining the Electrical System and Warning Symbols



CAUTION

**CAUTION!**

The electrical system of the Spreader is supplied with 12V voltage.

The User is responsible for the following maintenance activities on electrical system:

- the technical inspection of the electrical system and retro-reflectors,
- changing light bulbs.

Have the components of the electrical system repaired or regenerated by professional workshops having all appropriate qualifications and tools to perform this type of work.



CAUTION

**CAUTION!**

It is not allowed to drive, when the lighting system is non-operational. Damaged lamp lens and burnt bulbs must be immediately changed, before starting to drive. Change damaged or lost retro-reflectors.

Before driving on a public road, make sure that the lights and retro-reflectors are not dirty.

The scope of maintenance:

- check the condition of the electrical connection cable and the socket in the Spreader,
- check the lighting system for completeness, technical condition, and correctness,
- check all retro-reflectors for completeness and technical condition,
- check for the correct installation of the indicating plate for slow moving vehicles installed in the bracket,
- before driving on a public road, make sure that the tractor is equipped with a retro-reflective warning triangle,
- before driving on a public road, make sure that the lights and retro-reflectors are not dirty.

**Table 15** List of light bulbs

Lamp	Type of lamp	Bulb identification/ number	Number of lamps
Rear-light cluster, right	HOR45-LZT 478	C5W / 1 item P21W / 2 item	1
Rear-light cluster, left	HOR45-LZT 471	C5W / 1 item P21W / 2 item	1
Marker lamp, right	LO 355	C5W / 1 item	1
Marker lamp, left	LO 355	C5W / 1 item	1
Front running light, right	LO 093	W5W / 1 item	1
Front running light, left	LO 093	W5W / 1 item	1



Check the electrical system:

- each time the Spreader is coupled.

The Spreader lights are equipped with replaceable bulbs. If it is required to change the bulbs, remove the lens and change the bulbs to new ones with the same power rating and marking as the original ones. See Table 15 for a list of bulbs used in the Spreader lights.

## 5.8 Cleaning, Maintenance, and Storage

It is recommended to clean the Spreader thoroughly of any residual manure, after the completion of work.

After each “seasonal” manure spreading, thoroughly wash the Spreader with clean water, dry it, and carry out maintenance work. It is recommended to use pressure washers for cleaning. When cleaning, exercise particular caution.

Cleaning guidelines:

- Do not hold the water jet closer than 40cm from the surface to be cleaned. Washing surfaces with a strong jet of water from a short distance can damage lacquered surfaces,
- The water temperature must not exceed 50°C,
- Do not point the water jet directly at the following: electrical components, hydraulic and pneumatic components (cylinders, valves, connections), warning and information stickers, rating plate, lubricating points, etc.,
- If it is necessary to use cleaning agents, carry out a trial washing of the surface on an inconspicuous spot,
- Use petroleum ether or a degreasing agent to clean greasy parts, and then clean them with clean water,
- Do not use organic solvents or substances of unknown origin,

- Use suitable cleaning products to clean plastic or rubber surfaces,
- Wash the Spreader at locations designated for such purposes, according to the environmental protection regulations,
- Clean and dry the Spreader at a temperature above 0°C.



DANGER

**DANGER!**

Before cleaning, switch off the drive of the tractor, disconnect its PTO shaft, and shut down the engine. Remove the key from the ignition switch. Secure the tractor against unauthorised access.

It is only allowed to enter the hopper, when the machine is completely stationary.



CAUTION

**CAUTION!**

When washing, use the appropriate protective clothing and personal protective equipment.

Refer to the instructions for use, regarding cleaning products and the pressure washer.

After the thorough cleaning and drying of the Spreader, carry out proper maintenance work, replace missing paint coating, and lubricate the machine. After lubricating using the appropriate lubricating points, activate all mechanisms of the Spreader to distribute the grease.

Apply a small amount of oil or anti-corrosive products in the locations where the lacquered surface has rubbed off naturally as a result of friction of moving material or friction between the parts rubbing against one another.

Store the Spreader in a roofed area, adequately protected against unauthorised access. If stored outdoors, the Spreader will be exposed to corrosive agents and UV radiation, which cause ageing of the lacquer coating.



## 5.9 Tightening torques of screw connections

The optimum tightening torques for screws with metric threads are shown in Table 16.

**Table 16** Tightening torques for screws with metric threads

Screw		Tightening torques for screws with metric threads [Nm]					
Diameter d [mm]	Pitch of thread [mm]	Screw strength classes					Wheel nuts, wheel screws
		4.8	5.8	8.8	10.9	12.9	
3	0.50	0.9	1.1	1.8	2.6	3.0	
4	0.70	1.6	2.0	3.1	4.5	5.3	
5	0.80	3.2	4.0	6.1	8.9	10.4	
6	1.00	5.5	6.8	10.4	15.3	17.9	
7	1.00	9.3	11.5	17.2	25	30	
8	1.25	13.6	16.8	25	37	44	
8	1.00	14.5	18	27	40	47	
10	1.50	26.6	33	50	73	86	45
10	1.25	28	35	53	78	91	
12	1.75	46	56	86	127	148	
12	1.50						80
12	1.25	50	62	95	139	163	
14	2.00	73	90	137	201	235	
14	1.50	79	96	150	220	257	140
16	2.00	113	141	214	314	369	
16	1.50	121	150	229	336	393	220
18	2.50	157	194	306	435	509	
18	1.50	178	220	345	491	575	300
20	2.50	222	275	432	615	719	
20	1.50	248	307	482	687	804	400
22	2.50	305	376	502	843	987	
22	2.00						450
22	1.50	337	416	654	932	1090	500
24	3.00	383	474	744	1080	1240	
24	2.00	420	519	814	1160	1360	
24	1.50						550
27	3.00	568	703	100	1570	1840	
27	2.00	615	760	1200	1700	1990	
30	3.50	772	995	1500	2130	2500	
30	2.00	850	1060	1670	2370	2380	

## 5.10 Defects and Methods of Elimination

**Table 17** Defects and Methods of Elimination

Defect	Cause	Method of Elimination
Impacts on the conveyor during operation	Incorrect adjustment of the conveyor chain tension. Excessive extension of conveyor chains.	Check and adjust the tensioning of the chains.
Blocking the spreading adapter	The feeding speed of the floor conveyor is too high.	Reverse the floor conveyor to unblock the adapter and reduce the feeding speed.
	Blocking objects entering the spreading mechanism together with the manure.	Eliminate the cause of stopping the rotors of the adapter.
	Incorrect rotational speed of the PTO shaft of the tractor.	Change the rotational speed of the PTO shaft of the tractor.
	The PTO shaft operates at low speed.	Maintain the correct speed of the tractor's engine.
The floor conveyor does not deliver the loaded material towards the adapter	The knob on the flow controller is set to "0-1".	Increase the setting value on the flow controller.
	The weight of the material is too high – the floor conveyor is overloaded.	Unload part of the material.
	Low pressure in the hydraulic system of the tractor.	Check the pressure in the hydraulic system of the tractor. The minimum required hydraulic pressure in the tractor, measured with hot oil: 14MPa (140bar).
	The overload valve in the hydraulic engine of the floor conveyor is dirty and seized up.	Change the overload valve for a new one. Check the condition of the filters in the hydraulic system of the tractor - if necessary, change both filters and oil.
	Interrupted oil supply to the hydraulic motor of the conveyor.	Check the connection and airtightness of the hydraulic system.
The spread width is too small	Incorrect rotational speed of the PTO shaft of the tractor.	Change the rotational speed of the PTO shaft of the tractor.
	The PTO shaft operates at low speed.	Maintain the correct rotational speed of the tractor's engine.

## INDEX OF NAMES AND ABBREVIATIONS

**dB (A)** – scale A decibel, sound pressure unit;

**kg** – kilogram, weight unit;

**km** – kilometre, a commonly used multiple measure of the metre, the basic unit of length in the SI system;

**kPa** – Kilopascal, a pressure unit;

**HP** – horse power, power unit;

**m** – metre, length unit;

**mm** – millimetre, an auxiliary length unit equal to 0.001m;

**kPa** – Megapascal, a pressure unit;

**N** – Newton – a force unit in the SI system;

**Nm** - Newton-metre, a unit for the moment of force in the SI system;

**Pictogram** – an information plate;

**t** – tonne, a mass unit;

**Rating plate** - a Manufacturer's plate unambiguously identifying the machine;

**V** – Volt, a voltage unit;

**UV** – ultraviolet radiation, invisible electromagnetic radiation causing negative effects on human health; UV radiation has a negative effect on rubber parts;

**PTO** – Power take-off shaft;

**Transport hitch** – hitching components of a farm tractor (see the Instruction Manual of the tractor).

## ALPHABETICAL INDEX

### A

Adapter cover	34
Adjusting Fertiliser Doses	50

### B

Bearing-play adjustment	65
Bearings	60
Brake	38

### C

Chain-tensioning	54
Cleaning	64, 71
Coupling	45

### D

Defects	74
Design description	28
Draining	63
Drive unit	33

### E

Electrical system	39
Equipment	12

### F

Filter cleaning	62
-----------------	----

### G

Gear	56
------	----

### H

Hydraulic conduits	20
Hydraulic system	20, 34, 55

### I

Identification of the Spreader	9
Initial start-up	44
Intended use	10

### L

Lighting system	39
Load	28
Loading the hopper	48
Lubricating points	58-59
Lubrication	57

<b>O</b>	
Operating principle - brakes	34
Operation	42
<b>P</b>	
Pneumatic system	20, 34, 61
Preparing the machine for operation	42
PTO	21
<b>R</b>	
Rating plate	9
Residual Risk	23
<b>S</b>	
Safety	16
Shaft length adjustment	43
Slide gate	34
Spreading	49, 51
Spreading adapter	33
Stickers	23
Storage	71
Suspension	28
<b>T</b>	
Technical Data	28
The braking system	34
The feeding mechanism	32
Tightening torques	74
Transport	12
Tyres	68
<b>W</b>	
Withdrawal from use	15

## NOTES

Ruled area for notes, consisting of multiple horizontal dashed lines.





Since Metal-Fach Sp. z o.o. is continuously improving its products and adapting its commercial offer to fit the customers' needs, we reserve the right to modify our products without prior notice. Therefore, we advise contacting an authorised dealer or sales representative of Metal-Fach Sp. z o.o., before you make a decision about purchase. Metal-Fach Sp. z o.o. will not accept any complaints, regarding the data and pictures contained in the catalogue, as the presented range of products shall not constitute an offer, within the meaning of the provisions of the Civil Code.

The pictures do not necessarily show standard accessories.

Original spare parts are available from authorised dealers, both in Poland and abroad, and also at the Metal-Fach retail outlet.

#### **TECHNICAL SERVICE**

16-100 Sokółka, ul. Kresowa 62  
Tel.: +48 85 711 07 80; Fax: +48 85 711 07 93  
[serwis@metalfach.com.pl](mailto:serwis@metalfach.com.pl)

#### **SALE**

16-100 Sokółka, ul. Kresowa 62  
Tel.: +48 85 711 07 78; Fax: +48 85 711 07 89  
[handel@metalfach.com.pl](mailto:handel@metalfach.com.pl)

#### **SPARE PARTS WHOLESALE STORE**

16-100 Sokółka, ul. Kresowa 62

Wholesale:

Tel.: +48 85 711 07 80; Fax: +48 85 711 07 93  
[serwis@metalfach.com.pl](mailto:serwis@metalfach.com.pl)

Retail sale:

Tel.: +48 85 711 07 80; Fax: +48 85 711 07 93  
[serwis@metalfach.com.pl](mailto:serwis@metalfach.com.pl)

YOU CAN FIND CURRENT INFORMATION ABOUT OUR PRODUCTS ON [WWW.METALFACH.COM.PL](http://WWW.METALFACH.COM.PL)

