



METAL-FACH



MANURE SPREADER

N272/1 & N272/2

INSTRUCTIONS MANUAL – PART I

TRANSLATION OF THE ORIGINAL INSTRUCTIONS MANUAL

REVISION I

JANUARY 2019



EC DECLARATION OF CONFORMITY

The undersigned,	Jacek Kucharewicz, Chairman of the Board,	
hereby declares, with full responsibility, that the complete machine		
MANURE SPREADER		
1.1.	Brand (trading name of the manufacturer)	Metal-Fach
1.2.	Type	N272/1, N272/2
1.2.1.	Variant	-
1.2.2.	Version	-
1.2.3.	Product name(s) (if any)	Manure Spreader
1.3.	Category, Subcategory and Vehicle-Speed Indicator	R
1.4.	Company name and manufacturer's address	Metal-Fach sp. z o.o. ul. Kresowa 62 16-100 Sokółka, Poland
1.4.2.	Name and address of the authorised representative of the manufacturer (if applicable)	-
1.5.1.	Location of the rating plate of the manufacturer	On the front wall of the spreader structure
1.5.2.	Method used to fix the rating plate of the manufacturer	Riveted, glued
1.6.1.	Location of the vehicle-identification number on the chassis	On the front wall of the spreader structure
2.	Machine-identification number	
<p>complies with all the relevant regulations of Directive 2006/42/EC and the Regulation of the Minister of the Economy dated 21 October 2008 on the principal requirements for machines (Journal of laws of 2008, No. 199, item 1228, as amended)</p> <p>The following harmonised standards were applied to assess the compliance <u>PN-EN 690:2014-02, PN-EN ISO 12100:2012, PN-EN ISO 4254-1:2016-02,</u> <u>PN-EN ISO 13857:2010</u></p> <p>and standards PN-ISO 36002015, PN-ISO 116841998, and the Regulation of the Minister of the Infrastructure dated 31 December 2002 on the technical conditions of vehicles and the range of their essential equipment (Journal of Laws of 2003, No. 32, item 262, as amended).</p> <p style="text-align: center;">Safety-Testing Report No. LBC/49/11</p> <p style="text-align: center;">This declaration of conformity EC becomes null and void if the machine is modified or reconstructed without the manufacturer's consent.</p>		

Sokółka
(Place)

30/11/2011
(Date)

Jacek Kucharewicz
(Signature)

Chairman of the Board
(Position)

Machine data

Type of machine	Manure Spreader
Type designation	N272/1, N272/2
Serial number/ VIN ⁽¹⁾	_____
Machine manufacturer	METAL-FACH Sp. z o.o. ul. Kresowa 62 16-100 Sokółka Phone (0-85) 711 98 40 Fax (0-85) 711 90 65
Seller	_____
Address	_____ _____
Phone/Fax	_____ _____
Delivery date	_____
Owner or User	Name _____
Address	_____ _____
Phone/Fax	_____

⁽¹⁾The data is located on the machine-rating plate located on the front part of the machine's main frame

Table of contents

PART I

INTRODUCTION	7
1. General description	9
1.1 Introduction.....	9
1.2 Identifying the N272/1 and N272/2 Manure Spreaders	9
1.3 The intended use of the Manure Spreader.....	10
1.4 Basic equipment.....	12
1.5 Transport.....	12
1.6 Environmental hazards	14
1.7 Scrapping the machine	15
2. Safety of use	16
2.1 General safety principles	16
2.1.1 The obligation to provide information	16
2.1.2 General safety and use regulations	16
2.1.3 Operational safety.....	16
2.1.4 Machine operation	19
2.1.5 The pneumatic and hydraulic systems	20
2.1.6 PTO (Power Take Off) operation	21
2.2 Residual Risk	22
2.2.1 Forms of residual risk	22
2.2.2 Residual-risk assessment.....	22
2.3 Warning and information stickers.....	23
3. The design and principles of operation.....	28
3.1 The main technical data.....	28
3.2 The design and principles of operation	30
3.2.1 The feeding unit.....	31
3.2.2 The beater-drive unit.....	31
3.2.3 The 2-auger vertical beater unit	32
3.2.4 The 4-auger vertical beater unit	33
3.2.5 The 2-auger horizontal disc beater unit.....	34
3.2.6 The beater-unit shields	34
3.2.7 The spreader-structure gate	35
3.2.8 The main braking system.....	35
3.2.9 The parking brake.....	40
3.2.10 The electrical and lighting system	41
NAME AND ABBREVIATION INDEX.....	44
ALPHABETICAL INDEX	45
NOTES	47

PART II

4.	Instructions for use	7
4.1	Preparing the machine for operation	7
4.1.1	Checking the spreader after delivery	7
4.1.2	Preparing the spreader for start-up	7
4.1.3	Shifting the hitch position	9
4.1.4	Start-up	10
4.2	Coupling and decoupling the spreader	11
4.3	Loading the spreader structure	14
4.3.1	Loading and spreading lime	15
4.4	Fertiliser application-rate control and manure spreading	16
4.4.1	Fertiliser-application-rate control	16
4.4.2	Spreading manure	18
4.4.3	Clogged spreader beater unit	20
5.	Technical-service activities	21
5.1	Checking and adjusting the tension of the floor-conveyor chains	21
5.2	Checking the tension and tensioning the chains of the 2-auger horizontal disc-beater unit	22
5.3	Hydraulic-system maintenance	22
5.4	Gearbox maintenance	24
5.5	Lubrication	26
5.6	Pneumatic-system maintenance	30
5.6.1	System tightness and visual inspection of the pneumatic braking system	31
5.6.2	Air-filter cleaning	32
5.6.3	Draining the air tank	33
5.6.4	The replacement of flexible connection hoses	33
5.6.5	Cleaning and maintaining the pneumatic hose fittings	34
5.7	Driving-axle and brake maintenance	34
5.7.1	Driving-axle maintenance	34
5.7.2	Brake maintenance	35
5.7.3	Tyre maintenance - wheel changing	38
5.8	Maintaining the electrical system and warning devices	39
5.9	Cleaning, maintenance and storage	41
5.10	Tightening the torques of bolt connections	43
5.11	Faults and troubleshooting	44
	NAME AND ABBREVIATION INDEX	45
	ALPHABETICAL INDEX	46
	NOTES	48

INTRODUCTION

The information included in the Instructions Manual is valid as of the date of issue. The manufacturer reserves its right to make design changes to machines, and, due to this fact, some values or illustrations might not correspond to the actual state of the machine supplied to the user. The manufacturer reserves its right to make design changes without changing these instructions. The Instructions Manual is included as the basic equipment of the machine. The user is obliged to read the contents of this manual before commencing operation and to meet the recommendations included in it. It will ensure safe working.

The machine was constructed in compliance with the standards in force, and the current legal provisions. This instructions manual describes the basic safety and operational principles of the Manure Spreader made by Metal-Fach, types N272/1 and N272/2.

The material obligations of the manufacturer are presented in the Guarantee Certificate, which includes the complete regulations currently in force in the guarantee coverage.

If the information included in the instructions manual proves to be incomprehensible, you should address the seller from whom the machine was purchased, or the manufacturer directly, for assistance.

The spare-parts catalogue functions as a separate list, and is attached in the form of a CD during the machine purchase, and is also available on the Manufacturer's website www.metalfach.com.pl.

This Instructions Manual, according to the Act of 4 February 1994 on copyrights, and the related Laws Journal of Laws of 2018, item 1191, is protected by copyright. It is prohibited to copy and distribute the contents and Figures without the consent of the proprietor of the copyright.

The warranty card, together with the warranty terms, is attached to this Instructions Manual as a separate document.

The manufacturer's address

Metal-Fach sp. z o.o.

ul. Kresowa 62

16-100 Sokółka

Telephone

Phone (0-85) 711 98 40

Fax (0-85) 711 90 65

The symbols used in the instructions



DANGER

Hazard warning symbol - points to the occurrence of a serious hazard condition, which, if not avoided, can result in death or serious injury. The symbol warns against the most-dangerous situations.



NOTE

The symbol pointing to especially important information and recommendations. Non-compliance with the described recommendations threatens serious damage to the machine due to its incorrect operation.



WARNING

The symbol indicating the possibility of the occurrence of a hazard, which, if not avoided, can result in death or serious injury. This symbol indicates a smaller level of risk of injury than the symbol including the word "DANGER".



The symbol indicating useful information.



The symbol indicating service operations which should be performed periodically.

1. General description

1.1 Introduction

THIS USER MANUAL IS PART OF THE BASIC ACCESSORIES OF THE MANURE SPREADER

The machine may be operated only by persons who have read this Instructions Manual, know the design and functioning of the Manure Spreader, and the functioning of the tractor it works with.

To operate the machine safely, adhere to and follow all the Instructions set out in this Instructions Manual. Adhering to the guidelines of the Instructions Manual ensures the User works safely and the machine's service life is longer.

1.2 Identifying the N272/1 and N272/2 Manure Spreaders

The Manure Spreader should be identified using the nameplate, which is permanently attached to the loading box.

The data on the rating plate of the manure spreader are shown in Figure 1. The positions of the rating plate and serial number are shown in Figure 2.

METAL-FACH®		CE	
ul. Kresowa 62, 16-100 Sokółka, Poland tel.: +48 (85) 711 98 40-45, fax: +48 (85) 711 90 65			
Rozrzutnik obornika			
Typ/Wariant	N272/1	Masa własna	5920 kg
Data prod.	201	Nacisk na zaczep	30 kN
Nr fabr.	XXXXXXXXXXXX	KJ	
Dopuszczalna masa całkowita			17920 kg
Dopuszczalne obciążenie osi			145,8 kN
www.metalfach.com.pl			
METAL-FACH®		CE	
ul. Kresowa 62, 16-100 Sokółka, Poland tel.: +48 (85) 711 98 40-45, fax: +48 (85) 711 90 65			
Rozrzutnik obornika			
Typ/Wariant	N272/2	Masa własna	6160 kg
Data prod.	201	Nacisk na zaczep	30 kN
Nr fabr.	XXXXXXXXXXXX	KJ	
Dopuszczalna masa całkowita			20160 kg
Dopuszczalne obciążenie osi			167,8 kN
www.metalfach.com.pl			

Figure 1 The rating plate

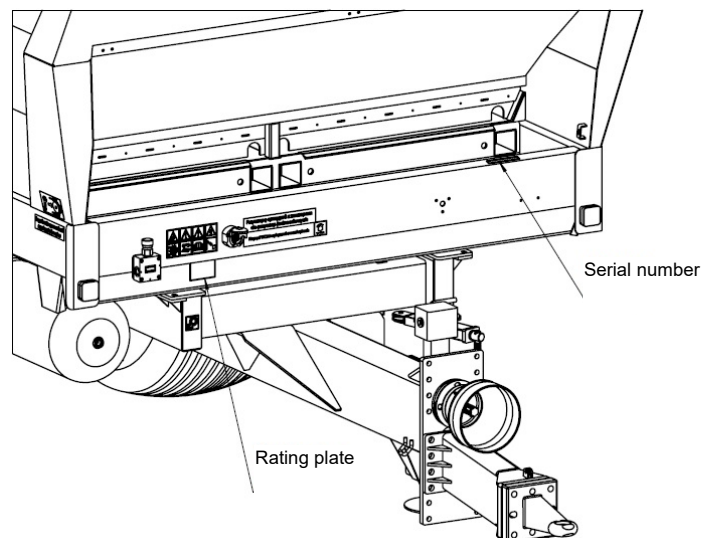

Figure 2 The positions of the rating plate and serial number

**NOTE****NOTE!**

Entering public roads without a rating plate or with an illegible rating plate is prohibited.



During the purchase, check the compliance of the factory number located on the machine-rating plate with the number written in the Instructions Manual and Guarantee Certificate - this is crucial for recognising the guarantee. In the event of user contact with the service, seller, or manufacturer, the user is obliged to quote the information included on the machine-rating plate.



The Instructions Manual is provided as part of the basic equipment of each Manure Spreader.

In the event of selling on the Spreader to another user, it is obligatory to provide the Instructions Manual. It is recommended for the Spreader supplier to keep a record of the Instructions Manual's receipt confirmation of receipt by the purchaser, to be submitted with the machine to the new user.

Please read the Instructions Manual carefully!

Applying its recommendations will allow you to avoid hazards, efficiently and productively operate the machine, and secure the guarantee for the duration period granted by the manufacturer.

**NOTE****NOTE!**

It is prohibited for persons who have not read this instructions manual to use the Spreader.

1.3 The intended use of the Manure Spreader

The manure spreader is designed for the even spreading of manure, peat, compost, etc., and for the transporting of agricultural products on farms and on public roads. It is not permitted to use the spreader in any other way than as described above.

The operator must use the machine in accordance with its intended use by carrying out activities involving the correct and safe operation and maintenance of the spreader, which should include

- reading and understanding the spreader's principles of operation
- the safe and correct operation of the machine
- the timely and regular maintenance of the machine
- compliance with the general safety regulations
- compliance with the provisions of the Road Traffic regulations.



DANGER

DANGER!

The Spreader must not be used contrarily to its intended purpose, in particular to

- carry people and/or animals
- operate it with exceeded payloads
- spread and transport toxic and flammable materials
- distribute liquids, sand, or fibrous substances
- carry goods, machinery, and equipment not secured, which, while driving, can shift their position, or affect the stability of the spreader
- carry out the transporting of building materials, individual objects, or any materials which are not included in its intended use

Unauthorised structural changes to the spreader voids the manufacturer's liability for consequential damage.

Table 1 The requirements for agricultural tractors

Description	Requirements	SU
Braking system Two-line braking system System rated pressure	Sockets acc. to PN-ISO-17282007 min. 650	kPa
Hydraulic system Hydraulic oil Nominal pressure Oil cleanness	HL 46 16 20/18/15 acc. to ISO 4406-1996	MPa
Electrical system Electrical-system voltage Connection socket	12 7-pole acc. to ISO 1724	V
Tractor hitch Minimum vertical load-bearing capacity of the hitch	3000	Kg
Minimum power demand of the tractor	N272/1 - 120 N272/2 - 120	HP
Minimum turning radius	6	m

1.4 Basic equipment

The basic equipment of each spreader includes

- The Instructions Manual
- Guarantee Certificate and warranty conditions
- Bracket for the plate indicating slow-moving vehicles
- Two-line pneumatic brakes with brake-force control (double-line pneumatic ALB (Anti-Lock Brakes), hydraulic, pneumatic-hydraulic, pneumatic-hydraulic ALB - optional)
- Parking brake
- Lighting system

1.5 Transport

The spreader is ready for sale fully assembled, and does not require further assembly. Delivery to the user takes place by road transport, or after coupling with a tractor for independent transport.



NOTE

NOTE!

The general health-and-safety regulations must be observed when loading and unloading the spreader. The persons operating the loading and unloading equipment must have the required authorisation to use the equipment.



NOTE

NOTE!

It is forbidden to attach slings of lifting devices to the upper mounting brackets of the structure and the beater unit to lift, load, or unload a complete spreader.

Fasten the spreader to be transported onto a platform by means of tie-down straps or chains, thus providing a tensioning mechanism. The fasteners must have a valid safety certificate. Place chocks or other parts without sharp edges under the wheels of the spreader to prevent the machine from rolling. The wedges must be attached to the platform of the means of transport. Special attention must be paid during loading and unloading so as not to damage the equipment of the spreader and its paint coating. Attach the fastening straps or chains to the lifting points/shipping brackets welded to the lower frame. The horizontal sections or other strong frame parts can also be used for this purpose.

Before loading onto the platform, connect it to the tractor's hitch and connect the brake-system lines. Loading onto a low-floor trailer must be done using unfolded ramps.



DANGER

DANGER!

The improper use of fasteners can cause an accident.



NOTE

NOTE!

Pay particular attention to the angle of inclination of the ramps of a low-loading platform. It may not exceed 10°.

The excessive inclination of the ramps can lead to damage to both the spreader and the transport trailer.

The spreader may be driven on public roads as a machine attached to the **lower or upper hitch** of the farming tractor.

Before merging with the traffic on public roads, make sure that the traffic is fully manoeuvrable. The front-axle load of the tractor must be at least 20% of the tractor's weight, which also applies during transporting and loaded-spreader operation. If this condition is not met the front axle of the tractor must be loaded.

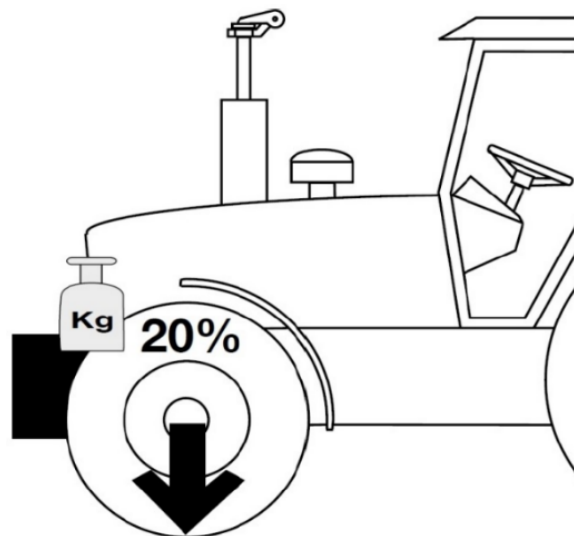

Figure 3 The minimum front-axle load of the tractor



NOTE

NOTE!

During the transporting of the machine on public roads, adapt the speed to the traffic conditions, and do not exceed 40km/h.

Prior to spreader transportation make sure that

- the spreader is properly coupled to the tractor and the hitch device is secured against accidental disconnection
- both the spreader's and the tractor's braking systems are functioning correctly
- both the spreader's and the tractor's lighting are working correctly and the front-position lamps of the spreader are in transport setting
- the beater shields are closed
- the structure gate is in its lowest position
- the hydraulic and pneumatic hoses are arranged in such a way that they are protected from damage during travel
- the support leg is lifted to its maximum setting and the hydraulic valve of the support leg is closed
- the parking brake is released.

During the transporting of the spreader on public roads, adhere to the road-traffic regulations.

During an emergency pulling over of the tractor with the machine attached the driver must

- ensure that any hazard to safety on the road is avoided when stopping the vehicle
- park the vehicle as close to the edge of the road as possible, parallel to the road's centre line
- stop the tractor's engine, remove the key from the key switch, engage the auxiliary brake, and place chocks under a spreader wheel
- outside built-up areas, place a warning triangle between 30 and 50 metres behind the vehicle and switch on the hazard lights
- in built-up areas, switch on the hazard lights and place a warning triangle behind the vehicle (if it is not mounted on a bracket on the rear of the machine) and always ensure that other road users can see it clearly
- in the event of a breakdown, take the appropriate steps to secure the area where the breakdown has occurred.

1.6 Environmental hazards

Direct causes of environmental hazard include hydraulic and gear-oil leakage. When oil-leakage risks occur, carry out all maintenance and repairs rooms with an oil-resistant surface. If oil is leaking, close off the source of the leakage and collect the spilled oil. Use absorbent materials to mop up the oil residues. Store all pollutants thus collected in tightly closed, oil-resistant, and marked, containers.



DANGER

DANGER!

Store used hydraulic and gear oil or any collected residues mixed with absorbent materials in tightly sealed containers. Do not use food containers for this purpose.



NOTE

NOTE!

Send all waste oil for disposal in accordance with the applicable regulations.

It is forbidden to dispose of oil into drains or water reservoirs.

1.7 Scrapping the machine

If you decide to scrap the machine, you must comply with the national regulations for the destruction and recycling of end-of-life machines. Before dismantling, remove all oil from the hydraulic system and gearboxes. Reduce the air pressure in the braking system to a minimum.



DANGER

DANGER!

When dismantling, use suitable tools, lifting equipment, and personal protective equipment, such as gloves, shoes, protective clothing, goggles, etc.

Avoid skin contact with oil. Do not allow oil leaks.

Send all waste oil for disposal in accordance with the applicable regulations.

When replacing worn, damaged, or unrepairable parts and components, send them to recyclable material sites.

2. Safety of use

2.1 General safety principles

2.1.1 The obligation to provide information



NOTE

NOTE!

If the spreader is sold to further users, attach the Instructions Manual, and ensure the purchaser of the spreader undergoes training as indicated in the Manual.

2.1.2 General safety and use regulations

Before each commissioning, the spreader must be checked for safe operation.

- Observe the generally applicable safety and accident-prevention regulations and follow the information in this Instructions Manual
- Observe all the safety symbols, warnings, and information notes affixed to the spreader which provide important guidelines for safe operation
- Operate the spreader only if all the required devices are connected and protected against unintentional disconnection or opening (e.g. hitch and drawbar, couplings, PTO shaft)
- Before starting work, learn how to operate all devices and controls and their functions, as it will be too late to do this during the operation
- Persons under the influence of alcohol or other stimulants, and those who are not trained and do not hold proper driving licences, are forbidden to operate the spreader

2.1.3 Operational safety

- 1) Before using the product, the user must read and understand the contents of this Instructions Manual. Observe all Instructions in this Manual during operations.
- 2) If the information contained in this Manual is unclear, please contact the distributor running an authorised technical service on behalf of the Manufacturer, or contact the Manufacturer directly.
- 3) Careless and improper use and operation of the spreader, as well as failure to observe the recommendations contained in this Manual pose health risks.
- 4) Failure to observe the safety rules use poses a threat to the health and life of the operators and third parties.
- 5) Please note that during spreader operations some residual risks occur, so practising the safety rules must be a priority.
- 6) All safety-related information must also be passed on to all other spreader users and operators.
- 7) Any structural and functional modifications of the spreader release Metal-Fach Sp. z o.o. from liability for damage to property and/or health.
- 8) For power PTO transmission use only recommended PTO shafts with the correct parameters.
- 9) The use of PTO shafts without guards for power PTO transmission is prohibited.

- 10) Before starting to drive, check that the parking brake is released, and that the brake-force control is in the correct setting for the load status (this applies to a dual-line pneumatic system with manual brake-force control).
- 11) Check the immediate vicinity (children, bystanders) before starting. Pay particular attention in the event of reduced visibility.
- 12) After you have finished spreading, lower the gate completely, switch off the PTO drive, switch off the floor conveyor drive, and close the beater shields. Never leave the spreader with the gate open, the PTO shaft drive switched on, the floor conveyor drive switched on, or the beater shields open without supervision.
- 13) Mount the structure only when the spreader has come to a complete stop, the PTO shaft disengaged, the tractor's engine switched off, and the machine protected against unauthorised access.
- 14) Always regulate the switching on and off of the PTO shaft and hydraulically controlled components from the driver's seat.
- 15) Couple the spreader as prescribed, and only connect it to the recommended equipment, and secure the drawbar eye, with the tractor's transport hitch.
- 16) Special care must be observed when coupling and uncoupling the spreader to and from the tractor.
- 17) When installing and removing any support and safety devices and ladders, always position them so as to ensure safe operation.
- 18) Observe the acceptable axle loads, total mass, and transporting dimensions.
- 19) Check for the transporting equipment's connection, and inspect the brakes and lights, the vehicle's marking plate, and other protective devices.
- 20) Before driving, check the functioning of the lights and brakes and prepare the spreader in accordance with the Instructions provided in "Driving on public roads".
- 21) Ensure that the spreader is loaded in such a way that the material does not contaminate surfaces when travelling on public roads.
- 22) After you complete your work, and before you drive on public roads, remove any spreading material from the external parts of the machine to prevent it from being dropped and contaminating the road.
- 23) Note all changes in vehicle behaviour, steering, and braking performance, due to the loaded spreader's being coupled to it.
- 24) When driving with a coupled-up spreader, note how the load and/or inertia forces are distributed, especially if the load distribution is asymmetrical.
- 25) Do not stand within the range of the material being spread.
- 26) The spreading of manure is allowed only if
 - the spreader is coupled to the tractor
 - the tractor and spreader unit are standing on solid ground
 - the front axle load of the tractor is at least 20% of the tractor weight
 - no persons are standing in the spreading area
 - the tractor is aligned with the centre line of the spreader
 - a safe distance from power lines is kept
 - no strong gusts of wind are occurring, which can cause the spreading material to drift outside the permitted spreading area
- 27) If it is necessary to continue the final stage of spreading on a slope, drive the tractor and trailer down the slope. When spreading on sloping terrain, the ground slope should not exceed 10°.
- 28) Take care to avoid your fingers' and hands' being crushed when opening the shields.

- 29) Observe the signs warning against crushing, dragging, and snatching points when starting the spreader. There is a risk of crushing and injury when coupling and uncoupling the spreader to the tractor.
- 30) No person may stand between the tractor and the spreader unless the vehicle is protected against rolling with the use of a parking brake and/or wheel chocks.
- 31) Secure the spreader and the tractor against rolling when stationary.
- 32) Transporting the spreader with the structure gate raised, beater shields open, and ladder unfolded, are not allowed.
- 33) Keep a safe distance from power lines when lifting the structure gate.
- 34) When carrying out repair and maintenance work which requires that you enter the spreader structure, the tractor must be stationary and protected against the risk of the engine's starting and/or the unauthorised use of control components.
- 35) Always adapt your driving speed to the ambient conditions. Avoid sudden up or downhill turns on sloping terrain.
- 36) Maintain a sufficient safety clearance within the turning area of the unit.
- 37) When reversing, ensure that you have sufficient visibility (opt for another person's assistance).
- 38) When cornering, take into account the inertia of the spreader.
- 39) Observe a minimum turning radius of approx. 6 m when turning and reversing.
- 40) Remove any functional faults in the attached devices only with the engine switched off and the ignition key removed.
- 41) In the event of a failure of the hydraulic or pneumatic system, the spreader must be taken out of service until the failure has been remedied.
- 42) It is forbidden to carry out maintenance or repair work when the spreader structure is loaded.
- 43) Before carrying out repair work on the hydraulic or pneumatic systems, the oil and/or air pressure must be reduced.
- 44) In the event of injuries sustained from a strong hydraulic oil jet, consult a physician immediately. Hydraulic oil can penetrate under the skin or into the eyes and cause infections.
- 45) Use the hydraulic oil recommended by the Manufacturer. Never mix two types of oil.
- 46) Switch off the engine and remove the ignition key before leaving the tractor. Engage the parking brake and secure the spreader with a chock.
- 47) When driving on public roads, do not exceed the 150.1 kN the maximum-permissible load on both axles for the N272/1, and 172.1 kN for the N272/2.
- 48) Exceeding the permissible technical payload volume of the spreader can lead to damage to the machine, loss of stability while driving, and spillage of the load, as well as compromising the road safety. The braking system has been adapted to the maximum-permissible weight of the spreader, which, if exceeded, will considerably reduce the main brake performance.
- 49) It is forbidden to exceed the permissible driving speed.
- 50) The maximum allowable pressure in the hydraulic system is 16 MPa.
- 51) The maximum allowable pressure in a double-line pneumatic system is 0.80 MPa, and the minimum is 0.65 MPa.
- 52) Preparing the spreader for operation (connecting hydraulic hoses, pneumatic systems, PTO shaft, etc.) must be made with the tractor's engine switched off and the ignition key removed.
- 53) The Manufacturer provides the spreader fully assembled.

54) Replace the hydraulic (rubber) lines every 4 years.

55) Noise – the equivalent A-weighted emission sound pressure level (LpA) should not be above 75 dB. The peak C-weighted instantaneous sound-pressure value (LCpeak) is 82±1 dB.

56) Keep the spreader clean.



WARNING

WARNING!

The risk of lightning strikes during the spreader's operations.

2.1.4 Machine operation

- While working, make sure that no people or animals are in the vicinity of the spreading area.
- It is forbidden to stand in the spreading area, because of the risk that the spreading material contains stones, wood fragments, or other objects.
- Before starting work, check the condition of the beater blades and their fasteners.
- Check the tension of the floor conveyor chains before loading. Regularly check the tension of the conveyor chains.
- When working next to roads, drainage ditches, plot boundaries, and water bodies, do not work beyond the designated spreading zone.

2.1.5 The pneumatic and hydraulic systems



NOTE

NOTE!

The pneumatic braking system is under high pressure.

Before starting work on the system, switch off the tractor's engine, secure the spreader with the parking brake and support chocks and depressurise it.

- When connecting pneumatic lines to the tractor's pneumatic system, ensure that the valves on the tractor's and spreader's sides are not under pressure.
- Check the pneumatic connection on a regular basis, and replace damage and ageing parts. The replacement of lines must comply with the manufacturer's technical requirements. Replace flexible pneumatic lines every 5 years, unless damage has been found earlier.
- Air leaks from the pneumatic braking system are not permitted.
- The hydraulic system is under high pressure during operation.
- Use the hydraulic oil recommended by the Manufacturer. Never mix two types of oil.
- Regularly check the technical condition of the hydraulic hose lines and connections.
- When connecting the hydraulic hoses to the tractor, ensure that the hydraulic system of the tractor and spreader is not under negative pressure. If necessary, reduce the residual pressure of the system.
- In the event of injuries sustained from a strong hydraulic oil jet, consult a physician immediately. Hydraulic oil can penetrate the skin and cause infections.
- Repair work on the pneumatic or hydraulic systems may only be carried out by an authorised representative of the spreader manufacturer.
- In the event of a failure of the hydraulic or pneumatic system, the spreader must be taken out of service until the failure has been remedied.



Replace flexible pneumatic lines every 5 years, unless damage is found earlier.

Replace rubber hydraulic hoses every 4 years, regardless of their technical condition, unless a fault is found earlier.



NOTE

NOTE!

Maintain the required cleanness of the 20/18/15 hydraulic oil according to ISO 4406-1996.

2.1.6 PTO (Power Take Off) operation

- The spreader may only be connected to the tractor by means of an appropriately selected PTO shaft recommended by the manufacturer.
- Before starting work, read and follow the Instructions Manual for the drive shaft.
- Connect and disconnect the PTO shaft only when
 - the spreader is coupled to the tractor hitch
 - the tractor's engine is switched off
 - the key is removed from the ignition
 - when the parking brake is applied
 - the PTO shaft is switched off
- Before starting the tractor with the spreader hitched, make sure that the PTO shaft drive in the tractor is switched off
- The PTO shaft must be fitted with guards
- It is forbidden to use the PTO without guards or with damaged components
- Mount the PTO shaft in accordance with the Operating Instructions provided by the manufacturer of the shaft
- Secure the PTO shaft sheaths against rotating, using chains; fasten the shaft chains to the fixed components of the spreader and the tractor
- The PTO sheath is marked indicating which end of the shaft to mount on the machine side and which on the tractor side; the protective couplings must always be fitted on the machine side
- After installing the PTO, make sure that it is correctly and safely connected to the tractor and spreader
- Each time you start the spreader, make sure that the PTO sheaths are in good working order and that they are correctly positioned; replace damaged or faulty components
- It is forbidden to wear loose clothing which can be caught by the rotating parts of the PTO shaft; contact with the rotating PTO shaft can result in serious injury or death
- When working in conditions of reduced visibility, use the tractor's service lights to ensure adequate sight of the working PTO shaft and its immediate area
- Transport and store the PTO shaft horizontally with chains fastened to prevent damage to sheaths and other components
- It is forbidden to overload the PTO shaft and the drive system of the spreader beaters; rapid starting of the tractor's PTO shaft is not permitted; before starting the PTO shaft, check that the direction of rotation is correct
- **Employ the appropriate PTO shaft speed during operation** - working at different speeds can damage the machine or its components
- Switch off the PTO shaft drive whenever there is no need to drive the machine, or when the tractor and spreader are in an unfavourable angular position
- Do not exceed the maximum-permissible operating length of the PTO shaft
- When uncoupling the PTO shaft from the tractor, place it in the specially designed holder
- It is forbidden to use chains for suspending or supporting the PTO shaft while the spreader is parked or transported.

2.2 Residual Risk

2.2.1 Forms of residual risk

Although METAL-FACH, with its office in Sokółka, assumes responsibility for the machine design and structure in order to eliminate hazards, some risks ensuing during the spreader's operation are inevitable.

Residual risk can occur due to the incorrect behaviour of the spreader operator, e.g. his or her carelessness, ignorance or improper behaviour. The following prohibited actions create the highest level of risk.

- 1) Operation of the spreader by minors and persons without a tractor driving licence, as well as persons who have failed to read the Instructions Manual.
- 2) Operation of the spreader by persons who are sick or under the influence of alcohol or other intoxicating substances.
- 3) Using the spreader for purposes other than those described in this Instructions Manual.
- 4) Standing between the tractor and the spreader while the tractor's engine is running.
- 5) Oil leakage and sudden movement of components caused by breakage of hydraulic hoses.
- 6) Standing on the machine during operation or transport.
- 7) Bystanders, children in particular, standing close to the running spreader.
- 8) The presence of persons or animals in areas not visible from the operator's position.
- 9) Cleaning, maintaining, and inspecting the spreader assemblies connected to the PTO shaft while the tractor's engine is running.
- 10) Checking the technical condition of the trailer during operation.
- 11) Operating defective power take-off shafts.
- 12) Exceeding the permitted speed and payload.
- 13) Making changes to the machine without the manufacturer's consent.

When specifying the residual risks, we assume that the spreader is a machine which was designed and manufactured state-of-the-art in the year of its manufacture.

2.2.2 Residual-risk assessment

Residual risk can be reduced to a minimum by applying the following recommendations

- 1) Adhere to the safety rules described in this instructions manual.
- 2) Use common sense when operating the machine.
- 3) Do not hurry when operating the machine.
- 4) Maintain a safe distance from prohibited and dangerous places.
- 5) Reaching into dangerous and prohibited places with your hands is forbidden.
- 6) It is forbidden to stand on the machine while it is in operation.
- 7) Have repair and maintenance work performed by trained personnel.
- 8) Wear the appropriate safety clothing.
- 9) Prevent unauthorised access, especially by children, to the machine.
- 10) Make sure no one is in the blind spot (especially when reversing and coupling).



NOTE





NOTE!









Failure to comply with the Instructions and guidance provided herein can result in residual risks!





2.3 Warning and information stickers

The manure spreader is marked with information and warning stickers. The user is obliged to ensure that the inscriptions, and warning and information pictograms on the spreader, are legible throughout the life of the spreader. If any information or warning sticker has been damaged or removed, place an order with the manufacturer or the distributor from whom the machine was purchased. Re-attach stickers to any new components which have been fitted during repair work. When cleaning, do not point a strong jet of water at the labels and do not use solvents.

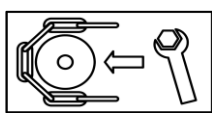
Table 2 Information and warning stickers

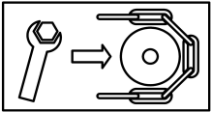
No.	Safety sign (mark)	Meaning of the sign (mark) or content of the inscription	Location on the machine
1.		Attention! Before you start operating the machine, read the Instructions Manual.	On the front wall of the spreader structure.
2.		Attention! Switch off the engine and remove the key before maintenance or repair.	On the front wall of the spreader structure.
3.		Attention! Risk of electric shock. Keep a safe distance from power lines.	On the front wall of the spreader structure.
4.		Attention! Torso-crushing hazard. Do not stand near the motion zone of the articulated coupling joints if the engine is running.	On the front wall of the spreader structure.

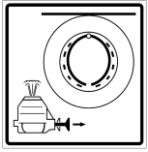
5.		<p>Attention! Danger of being dragged in by the drive train. Do not reach into the area of rotating parts.</p>	<p>On the hitch and at the rear on the right-hand side of the spreader structure.</p>
6.		<p>Attention! Ejected or dropped objects. Risk to the entire structure. Keep a safe distance from the machine.</p>	<p>On the beater frame.</p>
7.		<p>Attention! Hand-crushing hazard. Maintain a safe distance from moving parts.</p>	<p>On the beater frame.</p>
8.		<p>Attention! Danger of hand or upper torso's being dragged in by the augers of the beaters. Do not reach into the area of rotating parts.</p>	<p>At the rear on the spreader-structure wall. Near the beater unit.</p>
9.		<p>Attention! Risk of falling. Do not ride on platforms or ladders.</p>	<p>On the right wall of the spreader structure. Next to the ladder</p>
10.		<p>Attention! Danger of crushing toes or feet. Keep a safe distance from the support leg and drawbar.</p>	<p>Next to the support leg</p>
11.		<p>Attachment points of the transport tie-down straps</p>	<p>Next to the attachment points</p>
12.		<p>Lubrication points</p>	<p>Next to the key lubrication points</p>
13.		<p>Tensioning the floor conveyor chain</p>	<p>On the left wall of the spreader structure</p>

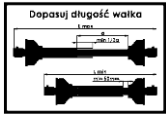
14.		Tensioning the floor conveyor chain	On the right wall of the spreader structure
15.		Speed limit 40 km/h	At the rear, on the lighting beam
16.		Pneumatic brake-release mechanism	On the front wall of the spreader structure
17.		PTO rotational speed	On the front sheath
18.		Jack-attachment point	On wheel drive axles
19.		Adjust the length of the shaft	On the hitch

	Warning inscriptions	Meaning of the sign (mark) or content of the inscription	Location on the spreader
20.		Check chain tension regularly	On the right and left sides of the spreader structure
21.		Do not enter the spreader structure when the drive is enabled	On the right wall of the spreader structure, next to the ladder
22.		Tighten the wheel nuts after a few kilometres, and then periodically	Above the ground wheels
23.		Beater unit weight kg	On the beater frame
24.		Payload capacity 14t – N272/2, 12t – N272/1	On the front wall of the spreader structure
25.		Switch off the PTO shaft drive when cornering.	On the front wall of the spreader structure

26.		Use a hitch for single axle trailers to couple a trailer.	On the front wall of the spreader structure
-----	--	---	---



NOTE

NOTE!

The user of the spreader must maintain the legibility of all warning inscriptions and signs attached to the trailer over the whole period of operation. If they are damaged or destroyed, replace them with new ones.

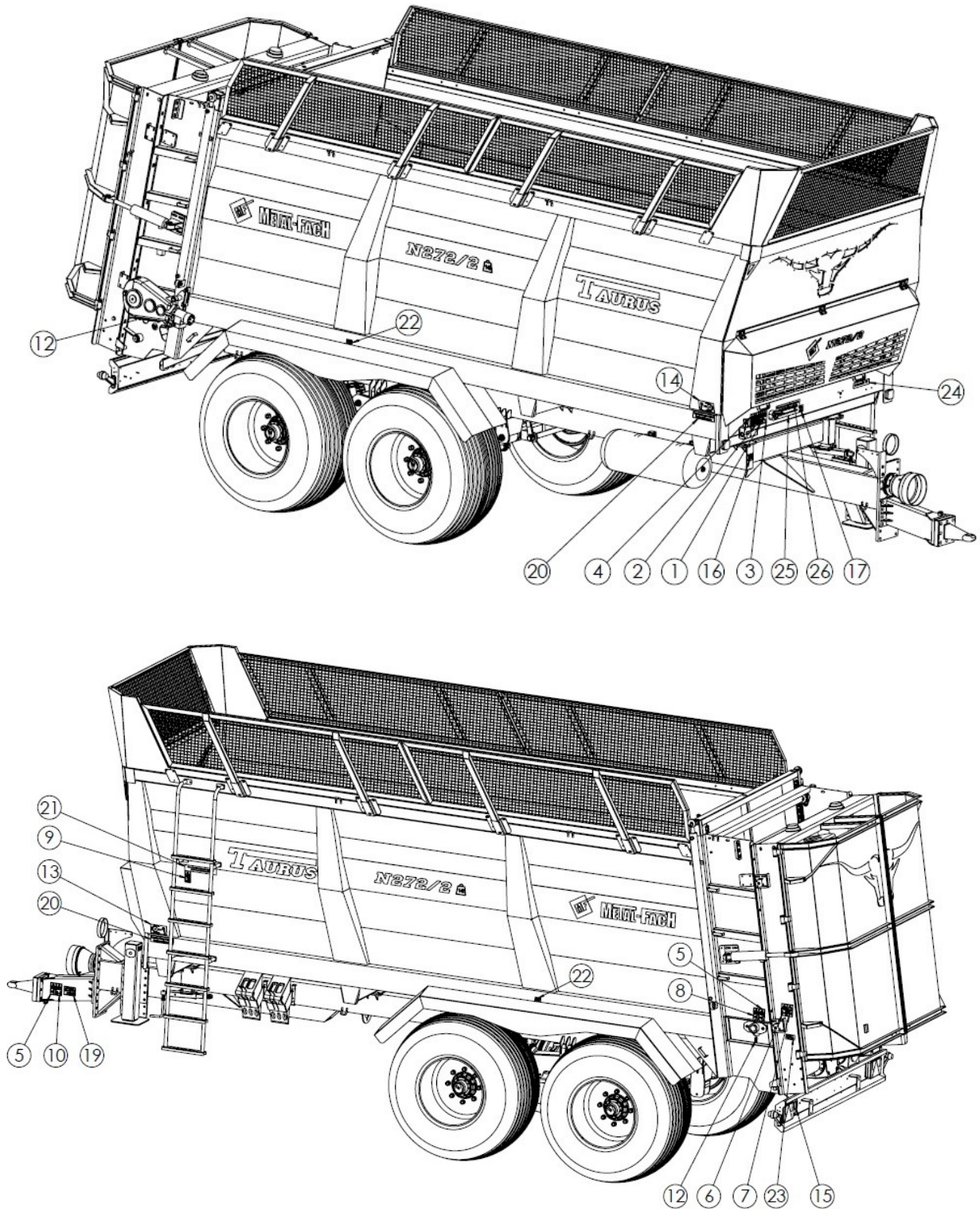

Figure 4 The location of warning and note stickers

3. The design and principles of operation

3.1 The main technical data

Table 3 The main technical data

No.	General data				
1.	Type of vehicle	Manure Spreader			
2.	Manufacturer	METAL-FACH Sp. z o.o., ul. Kresowa 62, 16-100 Sokółka			
3.	Type (Model)	N272/1, N272/2			
4.	Type of structure work	Monococque			
5.	Rating-plate location	Front-structure beam			
Dimensions					
		UOM	N272/1	N272/2	
6.	Length	mm	7900	7900	
7.	Width	mm	2545	2545	
8.	Height	Wheel 550/60-22.5"	mm	3330	3450
		Wheel 600/55-22.5"		3350	3470
9.	Wheel track	Wheel 550/60-22.5"	mm	1900	1900
		Wheel 600/55-22.5"		1900	1900
Internal dimensions of the spreader structure					
10.	Length	mm	5000	5000	
11.	Width (top/bottom)	mm	2000	2000	
12.	Height	mm	1280	1400	
Operating Parameters					
13.	Permissible total weight	With 2- and 4-auger vertical beater unit	kg	17920	20160
		With 2-auger horizontal disc beater unit		18360	20600
14.	Load capacity	kg	12000	14000	
15.	Permissible axle load	With 2- and 4-auger vertical beater unit	kg	14920	17160
		With 2-auger horizontal disc beater unit		15360	17600
16.	Kerb weight	With 2- and 4-auger vertical beater unit	kg	5920	6160
		With 2-auger horizontal disc beater unit		6360	6600
17.	Drawbar eye load (max.)	kg	3000	3000	
18.	Payload volume	m ³	12.6	13.8	
19.	Tractor power demand (min.)	HP	min. 120	min. 120	
20.		2-auger vertical beater unit	rpm	1000	1000

	PTO rotational speed	2-auger horizontal disc beater unit		1000	1000
		4-rotor vertical beater unit		540	540
21.	Maximum spreading width		m	8-12	8-12
22.	Maximum transport speed		km/h	40	40
23.	Working speed		km/h	4-10	4-10
Other data					
24.	Loading height	Wheel 550/60-22.5"	mm	2790	2910
		Wheel 600/55-22.5"		2810	2930
25.	Pressure in the hydraulic system (max.)		MPa	16	16
26.	Maximum pressure in the 2-line pneumatic braking system		MPa	0.80	0.80
27.	Electrical system voltage		V	12	12
28.	Wheelset (suspension)		-	Tandem, spring-mounted	
29.	Service brake		-	Mechanical, drum, pneumatically or hydraulically controlled	
30.	Parking brake		-	Mechanical, drum, hand-operated, via a worm gear, braking the front axle	
31.	Tyre size	Standard	-	550/60-22.5"	550/60-22.5"
		Optional		600/55-22.5"	600/55-22.5"
32.	Beater-unit type	Standard	-	Vertical 2-auger 2000x1680, fastened with bolts	
		Optional		Horizontal, disc, 2-auger 200x1830, fastened with bolts	
		Optional		Vertical 4-rotor 2000x1480, fastened with bolts	
33.	Beater-unit weight	2-auger, vertical	kg	960	
		2-auger horizontal disc		1000	
		4-rotor, vertical		470	
34.	Effective spreading width		m	8	8
35.	Spreading-strip width		m	12-15	12-15
36.	Spreader structure gate		-	Hydraulic control	
37.	Parking support		-	Hydraulic control	
38.	External ladder		-	Fixed with bolts on the left-hand side of the structure	
39.	Floor conveyor		-	Hydraulic drive	
40.	Tractor coupling type		-	Bottom or top hitch	

41.	Hydraulic oil (HL-46)		L	6	6.5
42.	Gearbox oil for floor feeder (gearbox 80W90)		L	4.3	4.3
43.	Gearbox oil for beater unit (gearbox 80W90)	2-auger vertical and horizontal	L	13.5	13.5
		4-auger vertical		7.5	7.5

The user must observe the permissible transport speeds for the maximum payload of the spreader.

If another brand of tyre is used, observe its parameters.

 <p>DANGER</p>	<p>DANGER!</p> <p>Failure to adhere to the permissible speed, tyre, and axle loads, can result in a serious accident.</p>
--	--

3.2 The design and principles of operation

The components of the spreader are shown in Figure 5. The main structural parts include a lower frame (4) with a tandem spring-mounted suspension (5) on which the spreader structure (7) is supported. A rigid hitch (2), equipped with a fixed drawbar eye (1), is used for connection with the tractor's lower or upper hitch. It is also possible to mount the eye for a rotary and ball drawbar. A hydraulic support foot (3) is attached to the drawbar to support the spreader when it is not connected to the tractor, and to adjust the height of the drawbar during coupling. A fixed ladder (17) is installed on the left-hand side of the structure wall to inspect the load compartment and enter the inside of the structure during cleaning or maintenance works. There is a hydraulically controlled gate (11) at the rear of the structure, to separate the loaded material from the beaters and prevent it from falling out during transport. The main operation component is the spreading beater unit (10) with two vertical augers. The loaded material is moved towards the beater unit by the chain feeder (13) fitted to the floor of the spreader structure. The beater unit is fitted with hydraulically controlled protective shields (10) to be used as spreading limiters (deflectors) during operation.

After installing the side-wall extensions (20) and removing the beater unit (10), the spreader can be used as a tipping manure conveyor.

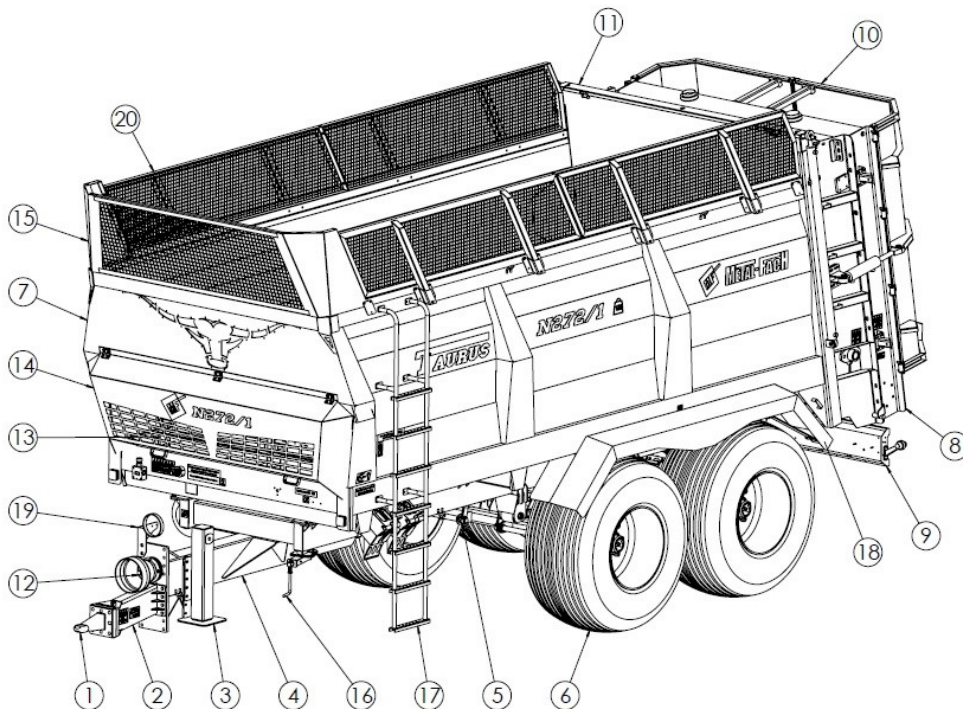

Figure 5 The main components of the manure spreader

1 - drawbar eye, 2 - hitch, 3 - support leg, 4 - bottom frame, 5 - suspension, 6 - ground wheel, 7 - structure, 8 - beater unit, 9 - lighting beam, 10 - beater shield, 11- structure gate, 12- drive unit, 13 - chain feeder, 14 - front guard, 15 - front extension, 16 - parking brake, 17 - ladder, 18 - mudguards, 19 - cable bracket, 20 - side extension

3.2.1 The feeding unit

The feeding unit consists of a floor conveyor, a feeder roller, and a tensioning system. The entire unit is driven by the tractor's hydraulic system.

The floor conveyor consists of two pairs of chains connected by scraper bars. The chains are driven by sprockets mounted on the feeder roller. The roller is supplied by a speed reducer and hydraulic motor. In the front part of the spreader there is a tensioning system for the chains of the feeder. The conveyor sprockets are fitted with scrapers to prevent sprocket clogging.

The floor conveyor is protected against damage by an overload hydraulic valve on the hydraulic motor. The conveyor is paused as soon as it is overloaded (or mechanically blocked).

3.2.2 The beater-drive unit

The drive unit of the beaters consists of a tractor's connection articulated shaft with a nominal torque of 900 Nm with a shear-bolt clutch, and a split-cage roller, which transmits the drive from the front part to the rear of the spreader, and an articulated shaft which transmits the drive to the beater unit. Optionally a wide-angle driveshaft (homokinetic) can be installed to enable work on headlands.

Table 4 The power take-off shafts

Tractor connection shaft sign	Hitch type	Nominal torque	Nominal length	Output power	Shear-bolt clutch
		Nm	mm	kW	Nm
*68R-802-2-HA-K68-1	K	900	725	51	2700
**680950/802.K68-1/5NW	P	900	1090	51	2700
**680060/S802.K68-1/5NW	P	900	1150	51	2700
Beater-unit connection shaft sign	Beater-unit type	Nominal torque	Nominal length	Output power	Shear-bolt clutch
680440/804.C6803A/5NW	P2	900	940	51	1300
680450/804.C6803A/5NW	T2	900	1090	51	1300
6T-602-3-BA-C644	P4	900	795	51	1300

Description of codes

K - short hitch, P - extended hitch, P2 - 2-auger vertical beater unit, P4 - 4-auger vertical beater unit, T2 - 2-auger disc horizontal beater unit

* the shaft to be used until 2019 with the short hitch

** the shaft used from 2019 with the extended hitch

*** the wide-angle shaft used as an option with the extended hitch

3.2.3 The 2-auger vertical beater unit

The 2-auger vertical beater unit is used for shredding and scattering material supplied by the floor conveyor. The beater unit is mounted on the rear of the spreader. The beater unit is supplied by the drive unit and the PTO of the tractor.

The beater unit consists of a left beam (1), a right beam (2), and an upper beam (3) to form the beater unit's frame. In its lower part there is a gearbox (4), on which the vertical augers (5) and (6) are mounted. The main work tools are replaceable blades (7) fastened to the auger segments. The augers turn and shred the feed material to eject it backwards and sideways. The end of the lower part of the augers is fitted with discs with blades, which increase the material-spreading width.

The beater unit is fixed to the spreader structure with M16 bolts. To disassemble the beater unit

- disconnect the PTO shaft from the beater unit gearbox
- remove the beater shields
- remove the bottom beater shields
- remove the bolts fastening the beater unit to the structure
- use a lifting device with a lifting capacity of min. 1,200 kg to remove the beater unit
- after removing the beater unit, place it on a solid surface and secure it against tipping over.

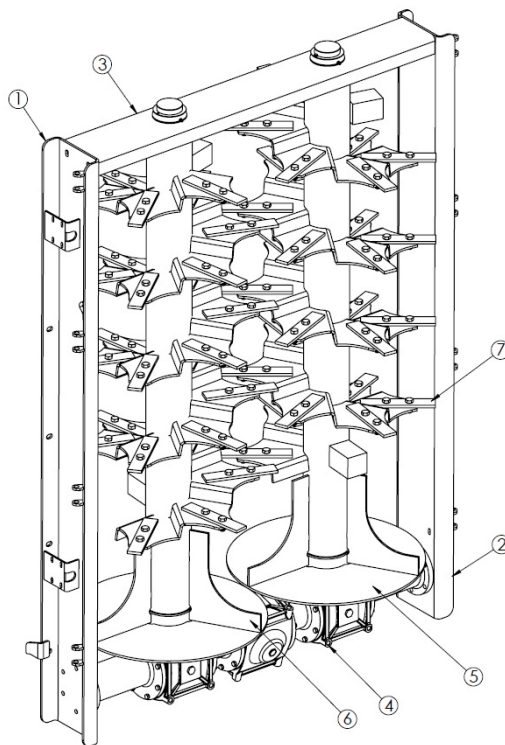

Figure 6 The 2-auger vertical beater unit

3.2.4 The 4-auger vertical beater unit

The beater unit consists of a left beam (1), a right beam (2), and an upper beam (3), to form the beater unit frame. In its lower part there is a gearbox (4), on which the vertical augers (5) and (6) are mounted. The main work tools are replaceable blades (7) fastened to the auger segments. The augers turn and shred the feed material, ejecting it backwards and sideways. The end of the lower part of the augers is fitted with discs with blades, which increase the material-spreading width.

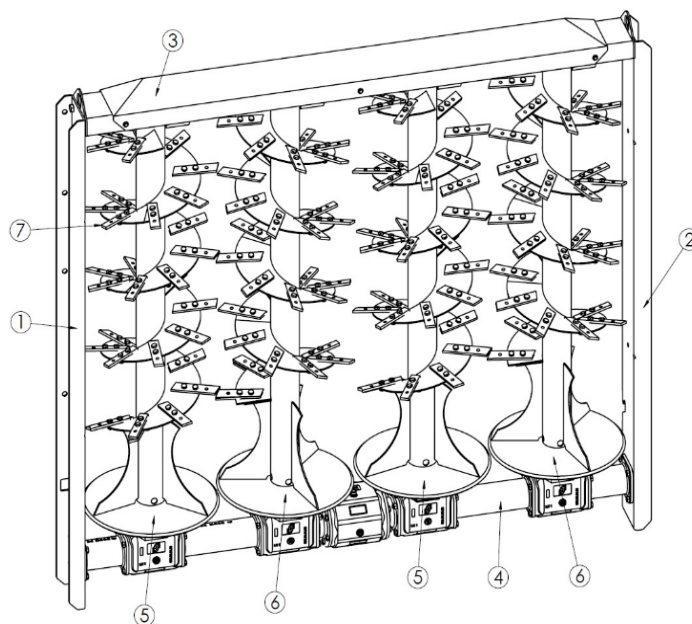

Figure 7 The 4-auger vertical beater unit

3.2.5 The 2-auger horizontal disc beater unit

The 2-auger horizontal disc beater unit (fig. 8) consists of a left beam (1), a right beam (2), and an upper beam (3), to form the beater unit frame. In its lower part there is a gearbox (4), on which the spreading discs (5) and (6) are mounted. The main work tools are replaceable blades (7) fastened to the horizontal augers (8) and (9). The augers shred the feed material, which is guided through the beater-unit shield on to the spreader discs. The rotating discs eject the shredded material backwards and sideways. The drive is supplied from the gearbox (4) to the horizontal augers (5) and (6) by the transmission chains under the shields (10) and (11). The auger is powered from the gearbox by the lower 16B2 chain (12). The top auger is powered from the bottom auger by the 20B1 chain (13). The chain tension is controlled by tensioners (14).

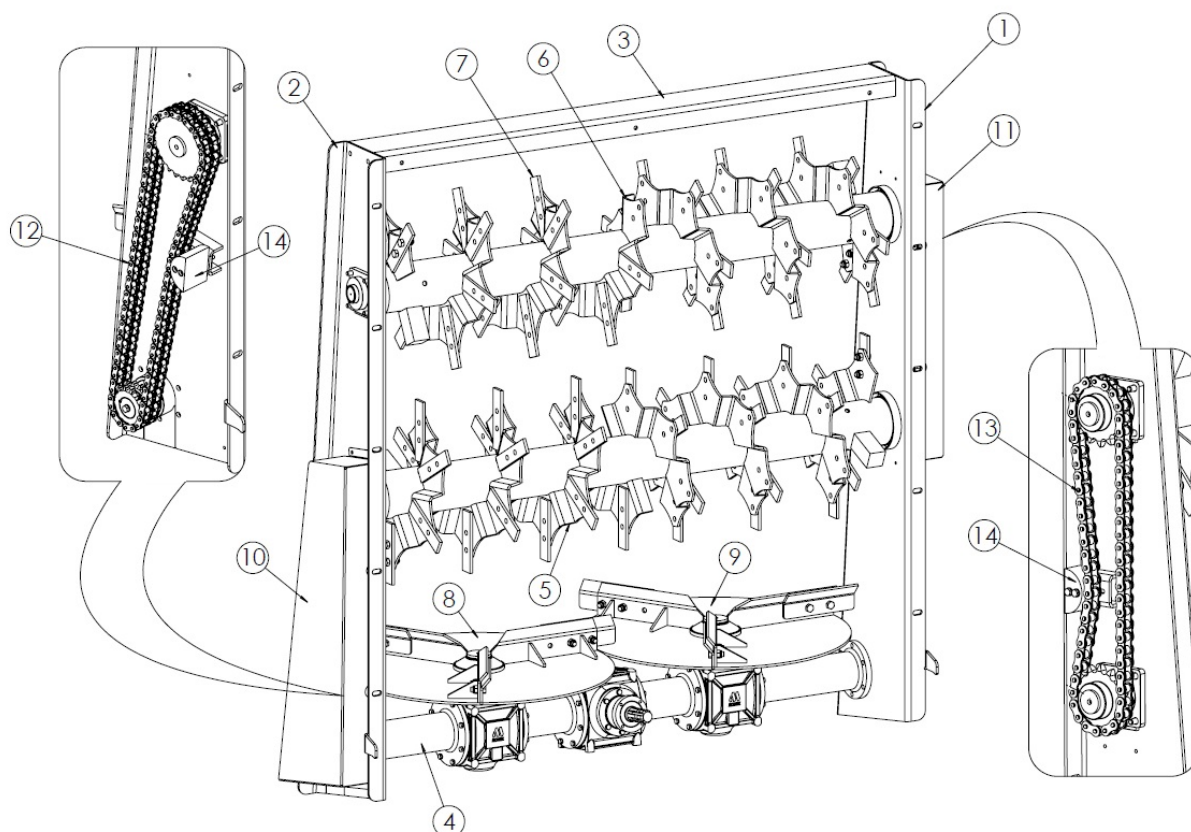

Figure 8 The 2-auger horizontal disc beater unit

3.2.6 The beater-unit shields

The beater-unit shields with vertical augers are attached to the beater unit by means of pins, and are opened or closed by means of hydraulic cylinders. They are controlled directly from the tractor cab via the lever of the external valve block. The right shield is additionally equipped with a shut-off valve so that it can be locked in any position. A partially opened shield can be used as a deflector to limit the spreading width of the material.

The shield of the disc horizontal beater unit is attached to the structure in its top section by means of hinges and is opened upwards by hydraulic cylinders. They are controlled directly from the tractor cab via the lever of the external valve block. Close the beater-unit shield for transporting and operating, and open it only during the time of technical inspection of auger components, cleaning and maintenance. The beater-unit shield is used as a wall hit during

operation by the shredded material. The shredded material then falls onto the beater-unit discs, which eject it evenly backwards and sideways. Working with the shield raised is allowed, but please note that this affects the even spread of the material, and you will have to keep closely to the previous track while doing the successive pass, which increases the number of passes.

3.2.7 The spreader-structure gate

The N272/1 and N272/2 spreaders are fitted with a structure gate as standard. It separates the material to be transported from the beater unit. It is contained in the side guides, which seal and protect the material against falling outside the spreader structure. The bottom section of the gate is reinforced, which as a result prevents its damage by excess manure pressing on it. At the bottom of the gate (as at the front of the structure) a rubber sealing belt is fixed, matching the shape of the conveyor chains.

The gate is opened by hydraulic cylinders, controlled by the tractor's external hydraulic system, to move it upwards.

3.2.8 The main braking system

The spreader can be equipped with one of five types of service braking system

- two-line pneumatic system (Figure 9)
- two-line pneumatic system with ALB valve (Figure 11)
- single-line hydraulic braking system (Figure 12)
- pneumatic hydraulic braking system (Figure 13)
- pneumatic hydraulic braking system with ALB valve (Figure 14)

The spreader is equipped with a two-line pneumatic system, with manual brake-force control as standard (Figure 9).

The service brake is activated from the driver's seat by pressing the tractor's brake pedal. The pneumatic control valve (2), used in the pneumatic system, enables the spreader's brakes simultaneously with the tractor's brakes.

In the event of accidental line disconnection [(5) and (6)], the control valve automatically applies the brakes of the machine.

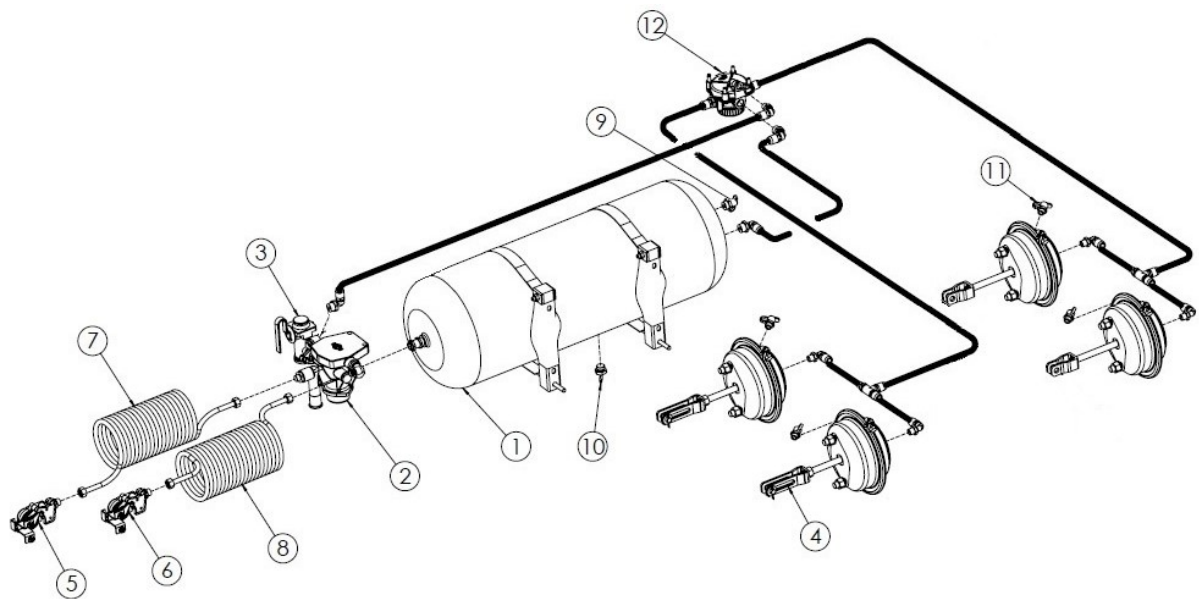

Figure 9 The 2-Line pneumatic braking system

1 - air tank, 2 - control valve, 3 - brake-force control, 4 - pneumatic cylinder (long fork), 5 - hose connection (red), 6 - hose connection (yellow), 7 - helical pipe (red), 8 - helical pipe (yellow), 9 - air tank control fitting, 10 - drainage valve, 11 - air cylinder control fitting, 12 - relay valve (accelerator)

Braking-force-control system (2) in Figure 10 is used in the pneumatic braking system to adjust the braking force according to the degree of the structure load. Switching to the correct operation mode is done manually by shifting the position of the lever (4). It is operated by machine operators before they start driving. Three work settings are available - (A) "UNLADEN", (B) "HALF LOAD", (C) "FULL LOAD".

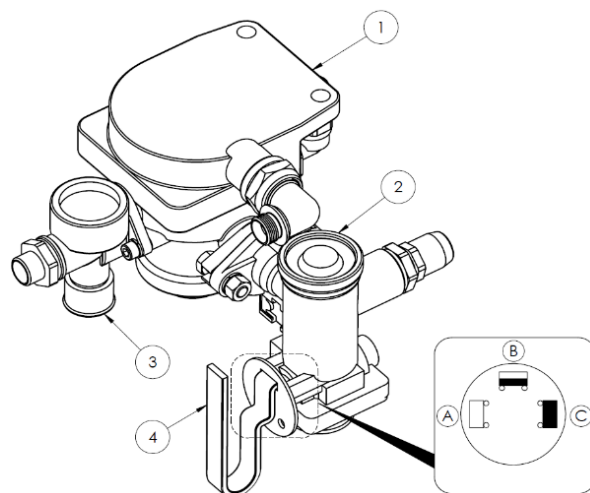

Figure 10 The control valve and brake-force-control system for 2-line pneumatic brakes

1 - control valve, 2 – brake-force control, 3 – brake-loading-release key for a parked spreader, 4 – control-mode-selection lever (A) "UNLADEN", (B) "HALF LOAD", (C) "FULL LOAD"



NOTE

NOTE!

The following work modes of the brake-force control are not allowed when driving with full load (A) "UNLADEN", (B) "HALF LOAD". Failure to follow this guidance can result in an accident.

Optionally, the spreader can be equipped with a 2-wire pneumatic brake with ALB (with automatic brake-force control) - Figure 11. The brake is activated from the driver's seat by pressing the tractor's brake pedal. The pneumatic control valve (2) enables the spreader's brakes simultaneously with the tractor's brakes. In the event of an accidental line disconnection (5) and (6), the control valve automatically applies the brakes of the machine. The ALB system features a valve (3) which automatically and continuously adjusts the braking force on the spreader wheels according to the load level of the structure.

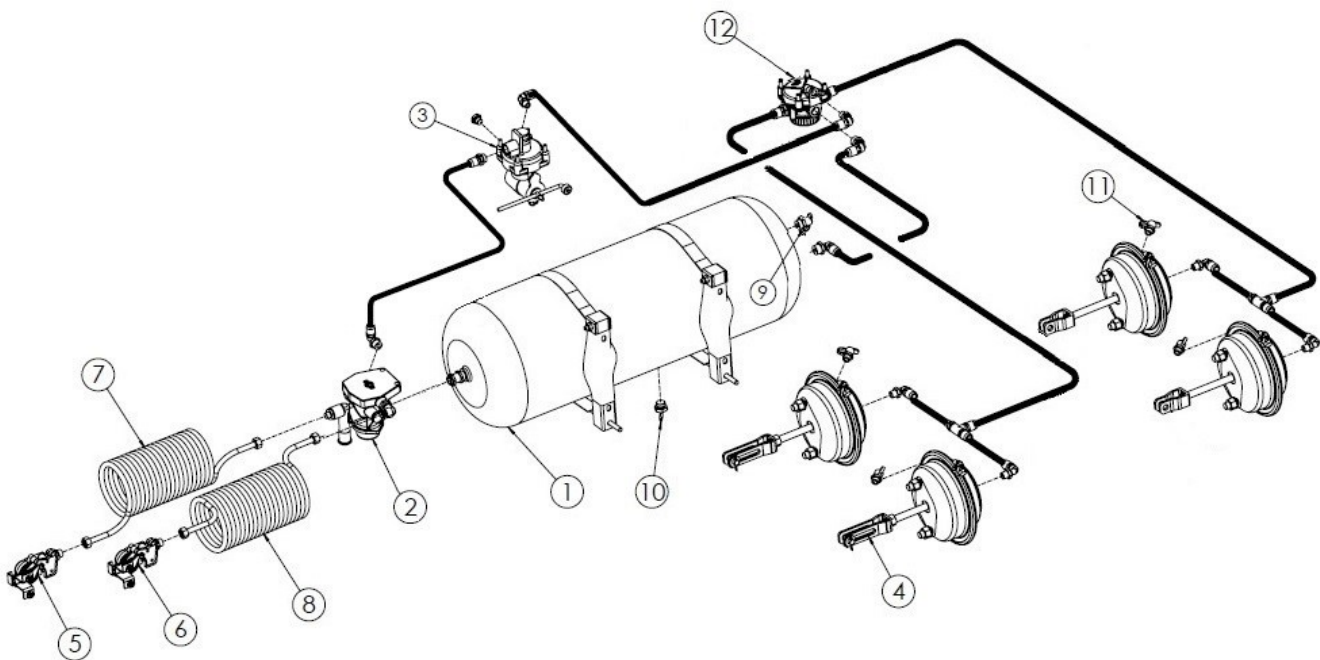

Figure 11 The 2-Line pneumatic braking system with ALB

- 1 - air tank, 2 - control valve, 3 - ALB valve, 4 - pneumatic cylinder (long fork), 5 - hose fitting (red), 6 - hose fitting (yellow), 7 - helical pipe (red), 8 - helical pipe (yellow), 9 - air-tank-control fitting, 10 - drainage valve, 11 - air-cylinder-control fitting, 12 - relay (accelerator) valve

The spreader can be optionally equipped with a hydraulic single-line braking system - Figure 12.

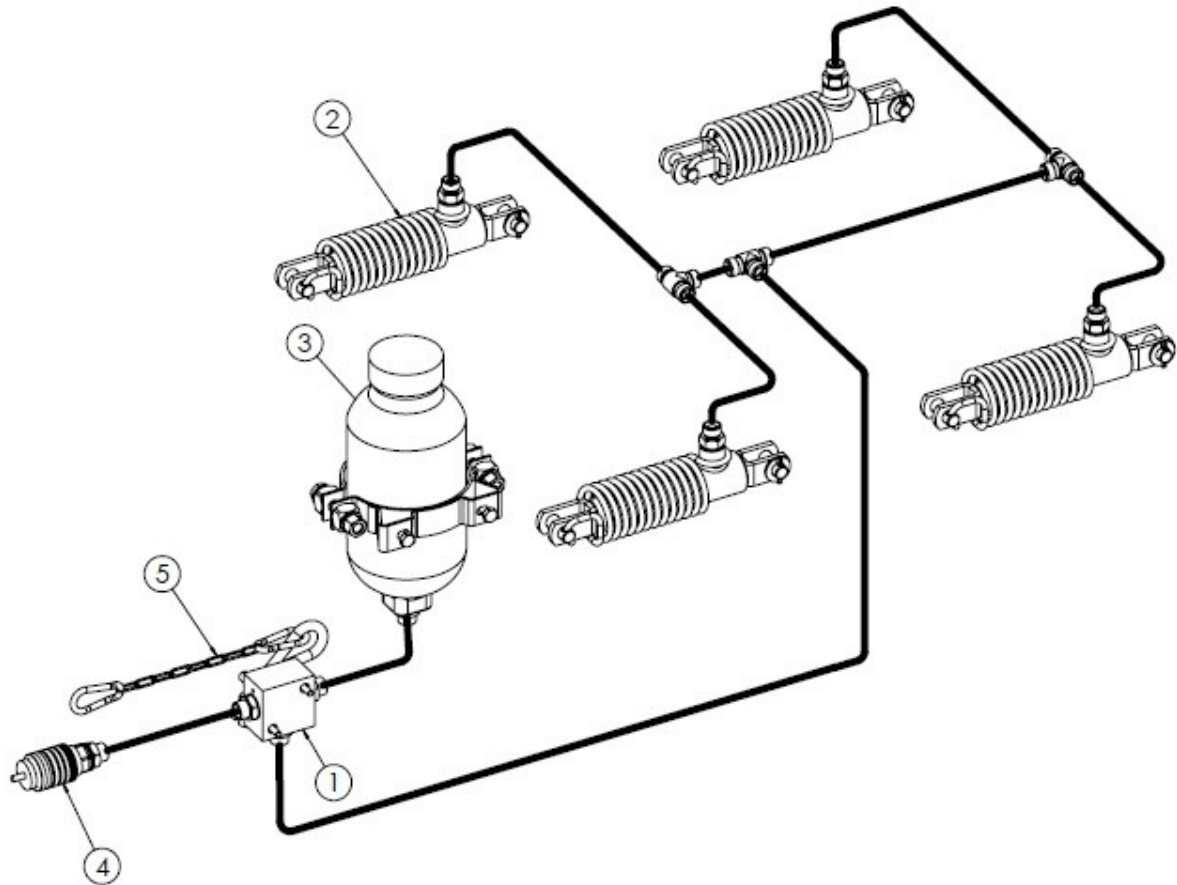

Figure 12 The 1-line hydraulic braking system

1 - emergency valve, 2 - brake cylinder, 3 - hydraulic accumulator, 4 - hydraulic quick coupling, 5 - activation chain for emergency valve.

The brake is activated from the driver's seat by pressing the tractor's brake pedal. The spreader brake is supplied and activated directly from the tractor's hydraulic braking system. In the event of an unforeseen disconnection of the spreader from the tractor coupling, the emergency valve (1) uses the chain (5) to apply the brakes of the machine.

Another option for the braking system is the hydraulic pneumatic braking system - Figure 13.

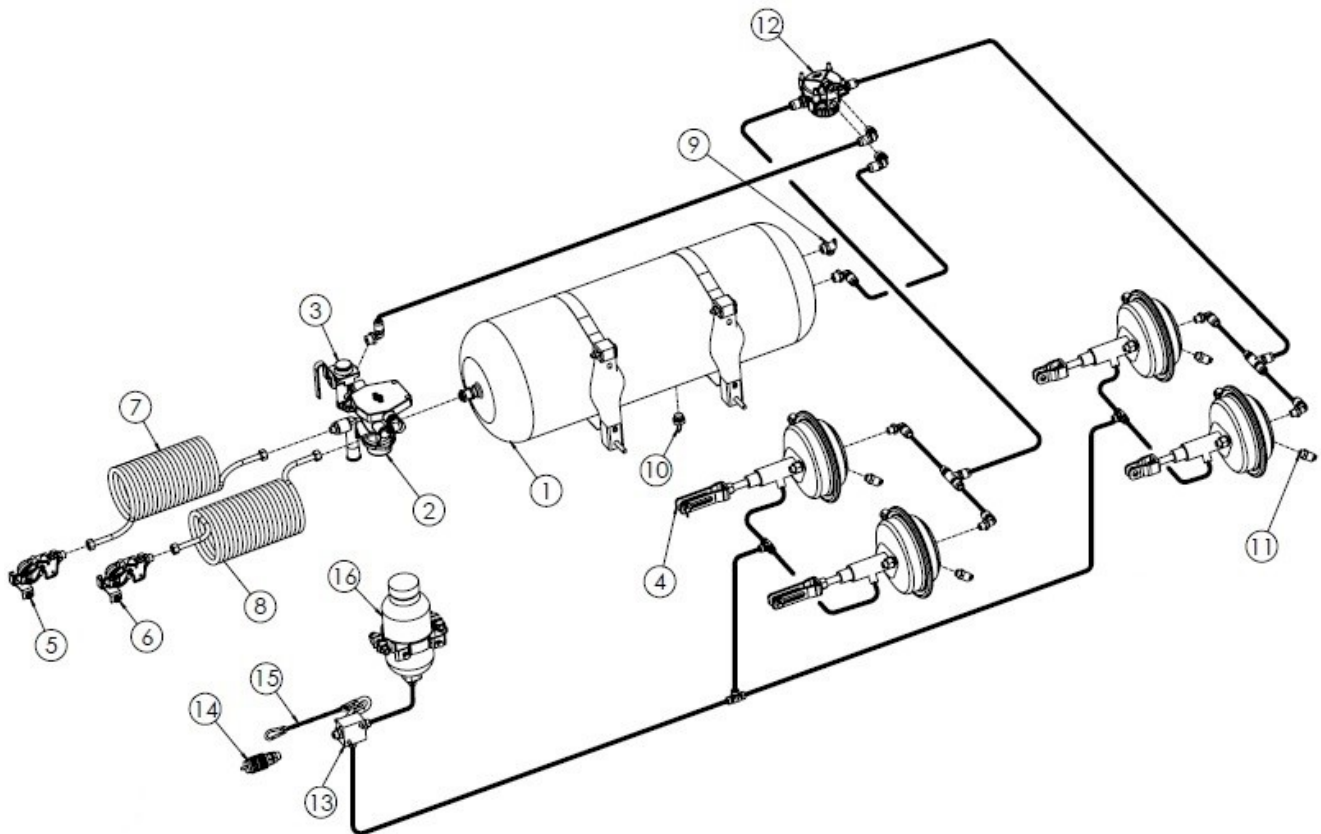

Figure 13 The hydraulic pneumatic braking system

(1) air tank, (2) - control valve, (3) - brake-force control, (4) - hydraulic pneumatic cylinder (long fork), (5) - hose fitting (red), (6) - hose fitting (yellow), (7) - helical pipe (red), (8) - helical pipe (yellow), (9) - air tank control fitting, (10) - drainage valve, (11) – air-cylinder control fitting, (12) - relay valve (accelerator)(13) emergency valve (14) hydraulic quick coupling (15) emergency valve activation chain (16) hydraulic accumulator.

This system is a combination of hydraulic and pneumatic 2-line braking with manual brake-force control. Whether you can connect the hydraulic or pneumatic braking system depends on the type of trailer brakes the tractor is equipped with.

Another option for the braking system is the hydraulic pneumatic braking system with ALB - Figure 14. This system is a combination of hydraulic and pneumatic 2-line braking with the ALB (manual brake-force control). Whether you can connect the hydraulic or pneumatic braking system depends on the type of trailer brakes the tractor is equipped with.

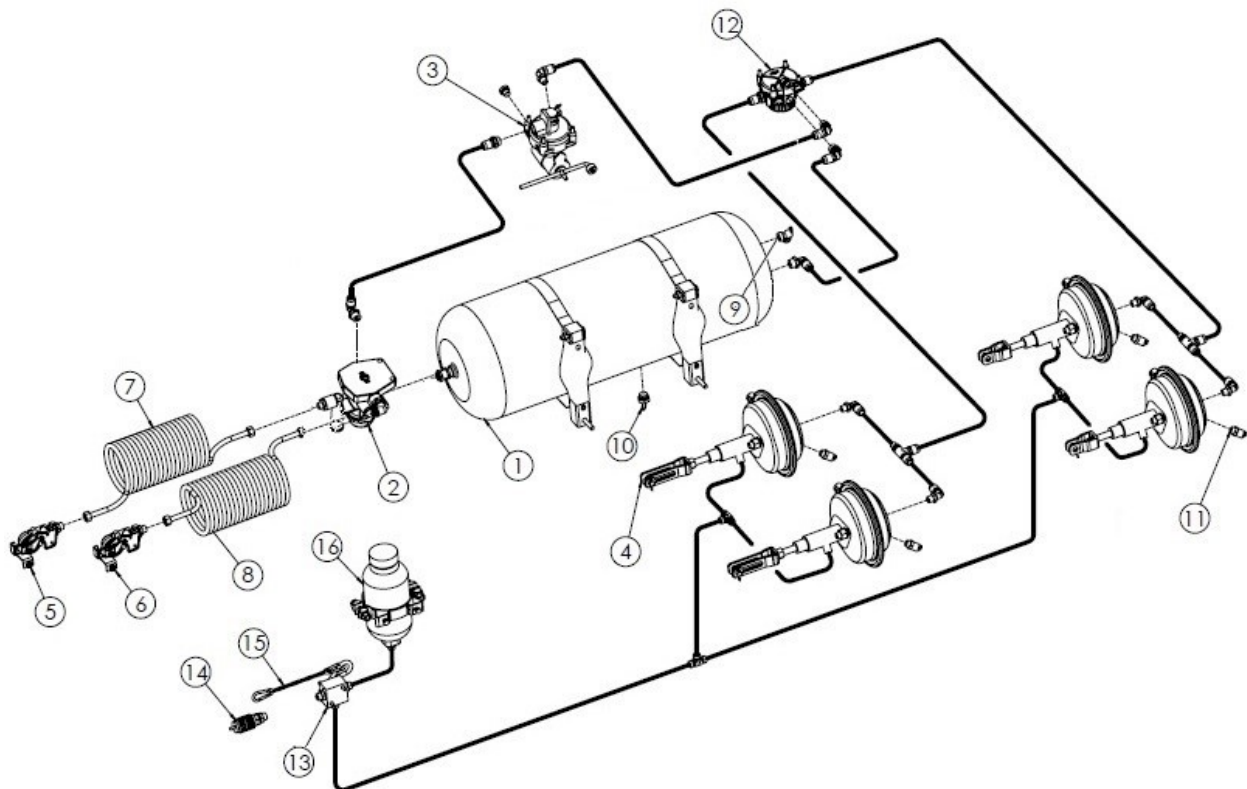

Figure 14 The hydraulic pneumatic braking system with ALB

(1) air tank, (2) - control valve, (3) - ALB valve, (4) - pneumatic cylinder (long fork), (5) - hose fitting (red), (6) - hose fitting (yellow), (7) - helical pipe (red), (8) - helical pipe (yellow), (9) – air-tank-control fitting, (10) - drainage valve, (11) – air-cylinder-control fitting, (12) - relay valve (accelerator) (13) emergency valve, (14) hydraulic quick coupling (15) emergency valve-activation chain (16) hydraulic accumulator.

3.2.9 The parking brake

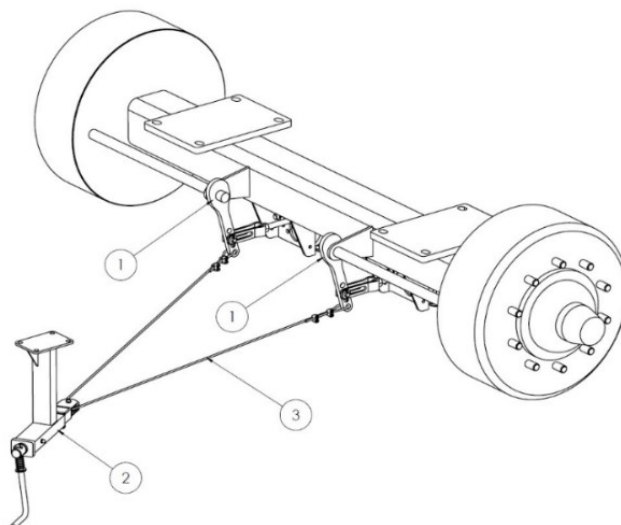

Figure 15 The parking brake

1 - expander lever, 2 - brake tension, 3 - steel cable

The parking brake is used to immobilise the spreader while it is parked. The components of the system are shown in Figure 15. The tension assembly (2) is mounted on the left-hand side of the structure. The expander levers (1) of the axle are connected to the crank device by means of a steel cable (3). Turning the crank of the tension assembly pulls the cable (3) and swivels the expander lever to activate the spreader brakes. The brake is released by turning the crank of the tension assembly to the left.

3.2.10 The electrical and lighting system

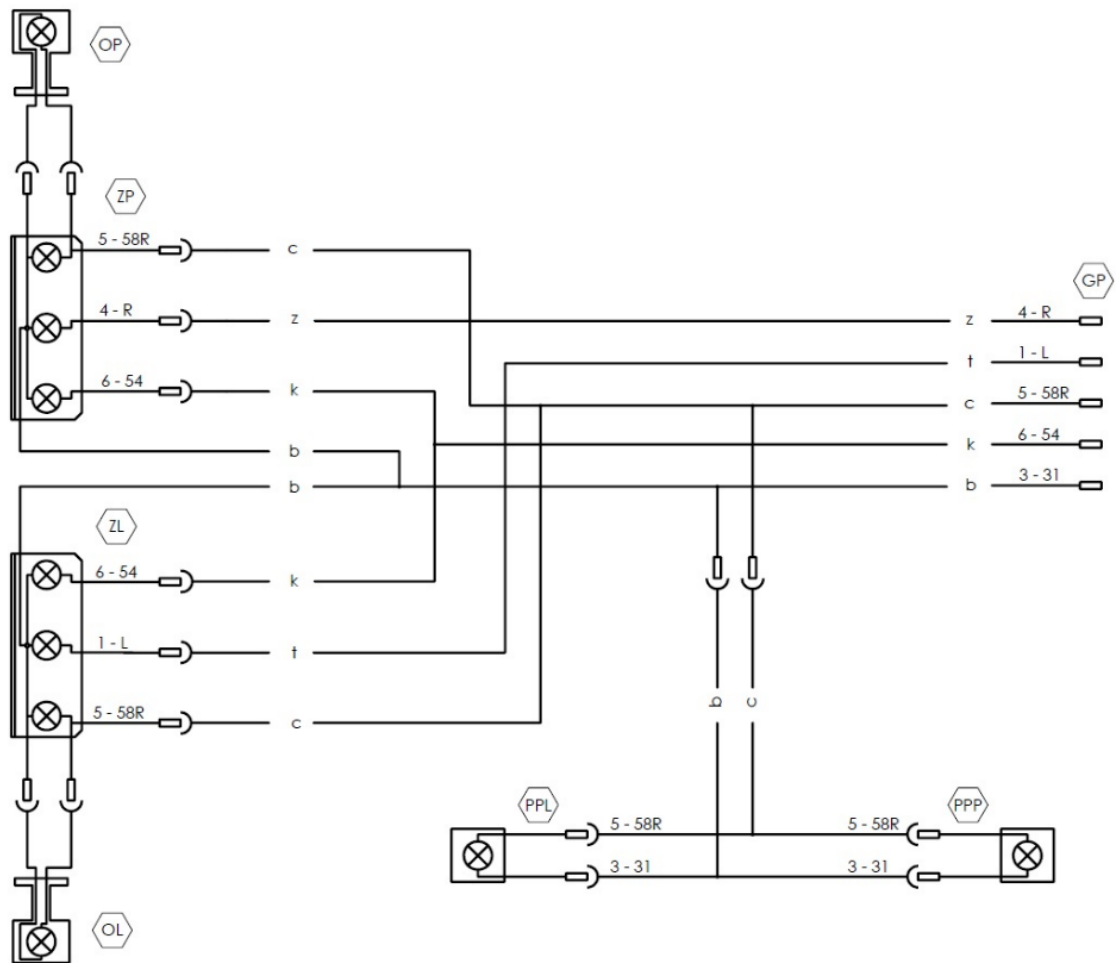

Figure 16 The wiring diagram

The electrical system of the spreader can supply power from a 12V DC power source from the tractor electrical system. Connect the electrical system of the spreader to the tractor system using the connecting cable supplied with the machine. The wiring diagram is shown in Figure 16, and the arrangement of the lights in Figure 17.

The colour codes for wires, electrical parts, and connections are given in Tables 5, 6, and 7.

Table 5 Cable colour codes

Code	Colour
c	Black
b	White
k	Red
t	Green
z	Yellow

Table 6 Electrical-part codes

Code	Name
ZP	Rear lamp cluster, right
ZL	Rear lamp cluster, left
GP	Connection socket
OP	Marker light, right
OL	Marker light, left
PPP	Front running light, right
PPL	Front running light, left

Table 7 GT socket-connection marking

Code	Function
1 - L	Indicator lamp, left
3 – 31	Earth
4 - R	Indicator lamp, right
5 – 58R	Running lights
6 – 54	Brake light

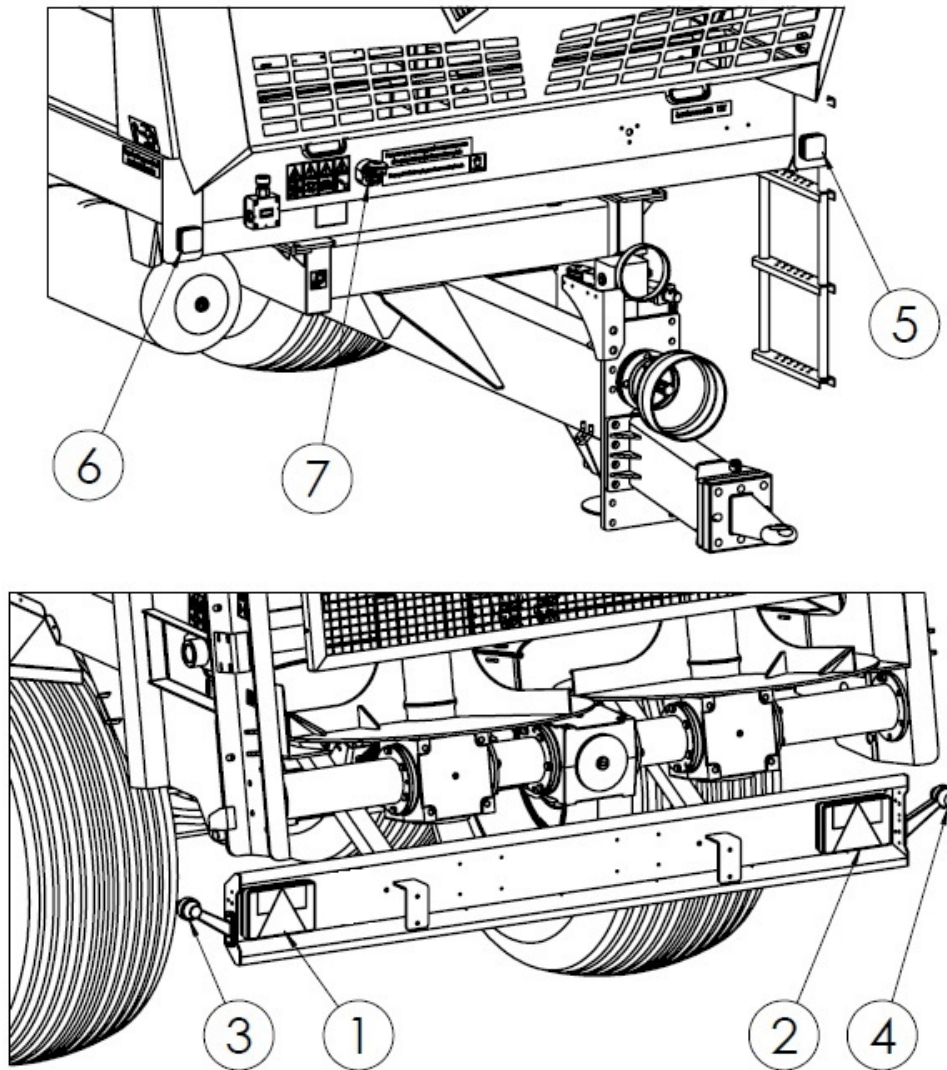

Figure 17 The arrangement of the electrical-system components
 1 – rear-left lamp cluster, 2 – rear-right lamp cluster, 3 - left marker light, 4 - right marker light,
 5 – front-left running light, 6 – front-right running light, 7 - connection socket

NAME AND ABBREVIATION INDEX

dB (A) – scale-A decibel, sound-pressure unit

kg – kilogram, weight unit

km – kilometre, a commonly used multiple measure of the metre, a basic unit of length in the SI system

kPa – kilopascal, pressure unit

m – metre, length unit

mm – millimetre, an auxiliary length unit equal to 0.001m

MPa – megapascal, pressure unit

N – newton – an SI force unit

Nm - Newton metre, a unit for moment of force in the SI system

Pictogram – an information plate

t – tonne, a unit of mass

Rating plate - a manufacturer's plate unambiguously identifying the machine

V – Volt, voltage unit

UV – ultraviolet radiation, invisible electromagnetic, invisible electromagnetic radiation with a negative effect on human health; UV radiation has a negative effect on rubber parts

Transport hitch – hitch components of an agricultural tractor (see the tractor's instructions manual).

ALPHABETICAL INDEX

PART I

B

Beater unit	34-36
Brakes, Operating principles	37
Braking system	37

D

Design description	32-33
Destruction, vehicle	17
Drive unit	32

E

Electrical system	43
Equipment	14

F

Feeding unit	33
--------------	----

G

Gate	37
------	----

H

Hydraulic lines	22
-----------------	----

I

Identification, Spreader	11
Intended use	12

L

Lighting system	43
Load	30

P

Pneumatic system	22, 37-38
PTOff	23

R

Rating plate	11
Residual Risk	24

S

Safety	18
Shields, Beater unit	36
Stickers	25
Suspension	30

T

Technical Data	30
Transport	14

PART II**B**

Bearing-play adjustment	35
Bearings	30-31
Brake	36-38

C

Chain tensioning	22, 23
Cleaning	33, 35, 42
Coupling	12

D

Drainage	34
----------	----

F

Failures	45
Fertiliser-dosage control	17
Filter cleaning	33

G

Gearbox	25
---------	----

H

Hydraulic system	23-24
------------------	-------

L

Loading the spreader structure	15
Lubrication	27
Lubrication points	27-29

P

Preparing machine for operation	8
---------------------------------	---

S

Shaft length adjustment	9
Spreading	16, 19
Start-up	11
Storage	43

T

Tightening the torques of bolt connections	44
Tyres	39-40

NOTES

A series of horizontal dotted lines for taking notes, spanning the width of the page.



Since Metal-Fach Sp. z o.o. is continuously improving its products and adapting its commercial product range to meet the customers' needs, we reserve the right to modify our products without prior notice. Therefore, we advise contacting an authorised dealer or sales representative of Metal-Fach Sp. z o.o., prior to making your decision about purchase. Metal-Fach Sp. z o.o. will not accept any complaints regarding the data and pictures contained in the catalogue, as the presented package must not constitute an offer, within the meaning of the provisions of the Civil Code.

The pictures do not necessarily show standard accessories.

Original spare parts are available from authorised dealers, both in Poland and abroad, and also at the Metal-Fach retail outlet.

SERVICE

ul. Kresowa 62, 16-100 Sokółka,
Tel. +48 85 711 07 80; Fax +48 85 711 07 93
serwis@metalfach.com.pl

SALES

ul. Kresowa 62, 16-100 Sokółka,
Tel. +48 85 711 07 78; Fax +48 85 711 07 89
handel@metalfach.com.pl

SPARE PARTS WHOLESALE STORE

ul. Kresowa 62, 16-100 Sokółka,

Wholesale

Tel. +48 85 711 07 80; Fax +48 85 711 07 93
serwis@metalfach.com.pl

Retail

Tel. +48 85 711 07 80; Fax +48 85 711 07 93
serwis@metalfach.com.pl