



METAL-FACH



FARMING-TRUCK TRAILER T730/1, T730/2, T730/3 INSTRUCTIONS MANUAL

TRANSLATION OF THE ORIGINAL INSTRUCTIONS MANUAL L
REVISION I

OCTOBER 2017



EC DECLARATION OF CONFORMITY

The undersigned	Jacek Kucharewicz, Chairman of the Board	
hereby declares, with full responsibility, that the complete machine		
Farming-Truck Trailer		
1.1.	Brand (the trading name of the manufacturer)	Metal-Fach
1.2.	Type	T730
1.2.1.	Variant	
1.2.2.	Version	
1.2.3.	Name(s) (if any)	N/A
1.3.	Category, Subcategory and Vehicle-Speed Indicator	R
1.4.	Company name and manufacturer's address	Metal-Fach sp. z o.o., ul. Kresowa 62, 16-100 Sokółka, Poland
1.4.2.	Name and address of the authorised representative of the manufacturer (if applicable)	N/A
1.5.1.	Location of the rating plate of the manufacturer	Front crossmember of the top frame of the trailer
1.5.2.	Method used to fix the rating plate of the manufacturer	Bonded
1.6.1.	Location of the vehicle-identification number on the chassis	Transverse front crossmember of the trailer, on the right-hand side
2.	Machine-identification number	
<p>complies with all the appropriate regulations of Directive 2006/42/EC and the Regulation of the Minister of the Economy dated 21 October 2008 on the principal requirements for machines (Journal of laws of 2008, No. 199, item 1228, as amended)</p> <p>The following harmonised standards were applied to assess the compliance <u>PN-EN ISO 4254-1: 2016-02, PN-EN ISO 13857: 2010, PN-EN ISO 12100: 2012</u> and standards: PN-ISO 3600:1998, PN-ISO 11684:1998 and Regulation of the Minister of Infrastructure dated 31 December 2002 on technical conditions of vehicles and the range of their necessary equipment (Journal of Laws of 2003, No. 32, item 262, as amended).</p> <p>Safety Testing Report No.: MF/2/2012</p> <p style="text-align: center;">This declaration of EC conformity becomes null and void if the machine is modified or reconstructed without the manufacturer's consent.</p>		

Sokółka
(Place)

01/08/2017
(Date)

Jacek Kucharewicz
(Signature)

Chairman of the Board
(Position)

Machine data

Type of machine	Farming-Truck Trailer
Type designation	T730/...
Serial number (1)	_____
Machine manufacturer	METAL-FACH Sp. z o.o. ul Kresowa 62 16-100 Sokółka Phone (0-85) 711 98 40 Fax (0-85) 711 90 65
Seller	_____
Address	_____ _____
Phone/Fax	_____ _____
Delivery date	_____
Owner or user	Name _____
Address	_____ _____
Phone/Fax	_____

⁽¹⁾ The data is located on the machine's rating plate located on the front part of the machine main frame

INTRODUCTION

The information included in the Instructions Manual is valid as of the date of issue. The manufacturer reserves its right to make design changes to machines, and due to this fact some values or illustrations might not correspond to the actual state of the machine supplied to the user. The manufacturer reserves its right to make design modifications without amending these instructions. The Instructions Manual is included with the basic equipment of the machine. The user is obliged to read the contents of this manual before commencing operations and to follow the recommendations included in it. It will ensure safe operation and a trouble-free machine operation. The machine was constructed in compliance with the standards in force and the current legal provisions. The instructions describe the basic safety and operation principles of the farming-transport trailer made by Metal-Fach, type T730.

The material obligations of the manufacturer are presented in the Guarantee Certificate, which includes the complete regulations currently in force in the guarantee coverage.

If any information included in the Instructions Manual proves to be incomprehensible, you should contact the seller from which the machine was purchased, or the manufacturer directly, for assistance.

The spare-parts catalogue functions as a separate, list and is attached in the form of a CD as part of the machine purchase, and also is available on the Manufacturer's website www.metalfach.com.pl.

This Instructions Manual in accordance with the Act of 4 February 1994 on copyrights and related Laws (Journal of Laws of 1994, No. 24, item 83) is protected by copyright. It is prohibited to copy and distribute the contents and figures without the consent of the proprietor of the copyright.

Manufacturer's address

Metal-Fach sp. z.o.o.

ul. Kresowa 62

16-100 Sokółka

Telephone

Phone (0-85) 711 98 40

Fax (0-85) 711 90 65

The symbols used in these instructions



DANGER

The hazard-warning symbol pointing to the occurrence of a serious hazard condition, which, if not avoided, can result in death or serious injury. This symbol warns against the most-dangerous situations.



WARNING

The symbol pointing to especially important information and recommendations. Non-compliance with the described recommendations threatens serious damage to the machine due to its incorrect operation.



WARNING

The symbol indicating the possibility of the occurrence of a hazard, which, if not avoided, can result in death or serious injury. This symbol informs on lower level of risk of injury than the symbol using the word “DANGER”.



The symbol indicating useful information.

Table of contents

INTRODUCTION.....	5
1. General description	9
1.1 Machine identification	9
1.2 Intended use.....	10
1.3 Basic equipment.....	11
1.4 Transport.....	12
2. Safety of use	13
2.1 Obligation to provide information	13
2.2 General safety and use regulations	13
2.3 Operational safety	13
2.4 Tyres	15
2.5 Pneumatic system	17
2.6 Operation and maintenance.....	17
2.7 Travelling on public roads.....	18
2.8 Warning/information signs and phrases on the trailer	18
3. Technical specifications, general data	21
4. General structure and operation description	23
4.1 Chassis.....	23
4.2 Load area	23
4.3 Hydraulic tilting mechanism of the load-carrying platform	23
4.4 Electrical system (signalling and warning).....	24
4.5 Brake system.....	25
5. Storage and sales	28
5.1 Storage.....	28
5.2 Purchasing the Trailer.....	28
6. Information on use.....	29
6.1 First start-up of the baler.....	29
6.2 Loading the load-carrying body.....	29
6.3 Driving on public roads	30
6.4 Unloading	30
6.5 Coupling and uncoupling the trailer with/from the tractor	32
7. Service activities.....	35
7.1 Instructions for using trailer components which require adjustment	35

7.1.1. Wheels – bearing-play adjustment	35
7.2 Brakes	36
7.2.1 Brakes – servicing the pneumatic-brake system.....	36
7.2.2 Brakes – adjustment of the pneumatic-brake system components	36
7.2.3 Brakes – servicing the hydraulic-brake system.....	38
7.2.4 Hybrid Hydraulic brakes – elements of operation	39
7.3 Wheels – tyres.....	40
7.4 The hydraulic system.....	40
7.4.1 The hydraulic system – the operation of the hydraulic tilting system of the load-carrying body	40
7.4.2 The hydraulic system – adjusting the hydraulic tilting mechanism of the load-carrying body	41
8. Faults and troubleshooting	43
9. Periodic maintenance	44
9.1 Lubrication.....	44
9.1.1. Other lubrication points	44
9.2 Technical-service activities	44
9.3 Repair instructions	45
9.4 Metrical bolt-tightening torques.....	46
10. Scrapping the trailer	47
11. Residual Risk	48
11.1 Residual-risk description.....	48
11.2 Residual-risk Assessment.....	48
WARRANTY TERMS	49
GUARANTEE CERTIFICATE.....	50
REPAIRS UNDER GUARANTEE.....	52
NAME AND ABBREVIATION INDEX	53
ALPHABETICAL INDEX.....	54
NOTES.....	56

1. General description

1.1 Machine identification

The identification of the trailer can be found on a plate on the front crossmember of the top frame of the trailer. The serial number of the trailer is stamped on the nameplate and underneath the nameplate on the machine frame.

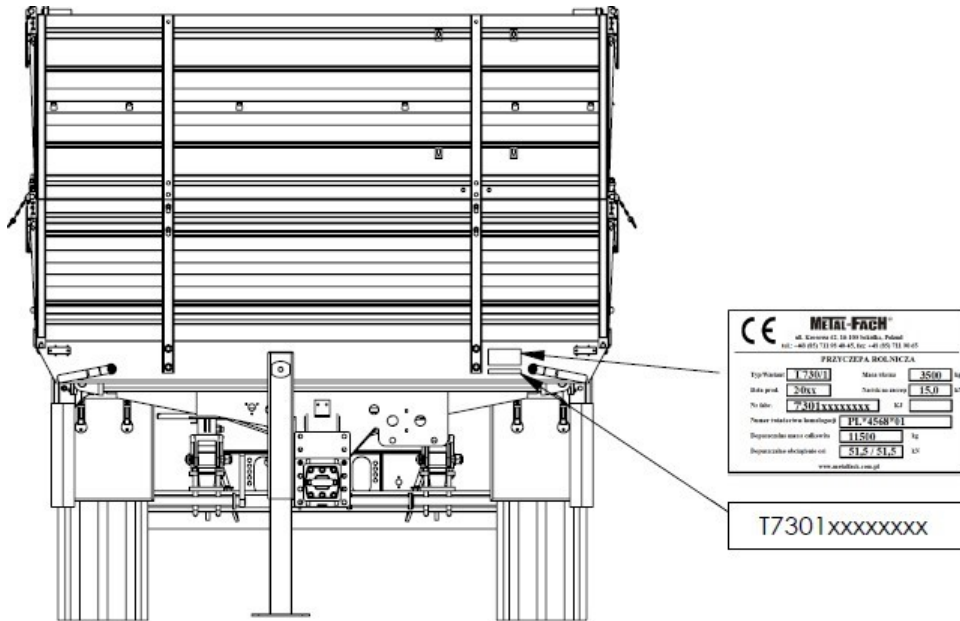

Figure 1. Location of the rating plate



WARNING

WARNING!

Joining public roads without the nameplate or with an illegible nameplate is prohibited.



When purchasing, check that the factory number located on the machine's rating plate matches the number printed in the Instructions Manual and on the Guarantee Certificate - it is crucial for verifying the guarantee. In the case of the user contact with the service, seller or manufacturer, the user is obliged to refer to the information included on the machine-rating plate.



The Instructions Manual is provided with the basic equipment of each trailer.

In the event of the selling of the machine to another user it is obligatory to provide the Instructions Manual. It is recommended for the machine seller to keep a record of the confirmation of the receipt, by the new user, of the instructions manual submitted with the machine.

Please read this Instructions Manual carefully!

Following its recommendations will ensure the avoidance of hazards, the efficient and productive operation of the machine, and validating the guarantee for the duration period granted by the manufacturer.



WARNING

WARNING!

The use of the trailer by persons who have not read these Instructions Manual is prohibited.

1.2 Intended use

The trailer is intended for the transporting of agricultural produce and other bulk and loose materials within farms and on public roads.

The trailer is unloaded either manually or by tilting the load-carrying body to the rear or to the sides. The trailer is designed to work with agricultural tractors equipped with external hydraulic systems, signal and warning-system sockets, brake systems, and transport hitches.

The trailer must not be used for the transporting of fuel, gas cylinders, or similar loads, because of the obligation to comply with the additional technical conditions for the carriage of dangerous goods.

The trailer must not be used for the transporting of fuels, gas cylinders, or toxic materials, which can cause environmental contamination. The manufacturer is not responsible for any resulting damage – this risk is borne by the owner.

The trailer may only be used by persons who are familiar with the operating instructions and who are trained in the risks, and in providing pre-medical assistance to the victims of accidents.

The appropriate accident prevention regulations, as well as other recognised principles of technical safety, occupational medicine and road safety, must be observed.

Unauthorised structural changes to the trailer remove the manufacturer's liability for consequential damage.



DANGER

DANGER!
The trailer must not be used contrary to its intended purpose, in particular

- to transport people and animals
- to transport unprotected toxic materials in bulk where there is a potential for environmental contamination
- to transport machinery and equipment whose centre of gravity adversely affects the stability of the trailer
- to transport loads which results in uneven loads and the overloading of the running axles
- to transport unsecured loads which can change their position on the load-carrying body while being driven.

Table 1 Requirements for agricultural tractors

Description	Requirements	SU
Brake system Two-line pneumatic system System's rated pressure	Sockets in acc. with PN-ISO-17282007 Min. 650	kPa
Hydraulic system Hydraulic oil Nominal pressure Oil cleanness	HL 46 16 20/18/15 in acc. with ISO 4406-1996	MPa
Electrical system Electrical-installation voltage Connection socket	12 7-pole in acc. with ISO 1724	V
Minimum vertical load-bearing capacity of the tractor hitch	2000	Kg
Minimum power demand of the tractor	T730/1 – 80 KM T730/2 – 90 KM T730/3 – 100 KM	
Minimum turning radius	6	m

1.3 Basic equipment

The basic equipment of each trailer includes

- Instructions Manual
- Guarantee certificate and warranty conditions
- Bracket for the plate indicating slow-moving vehicles
- Two-line pneumatic brakes (hydraulic optional) with adjustable braking force
- Parking brake
- Lighting system
- Sprung suspension.

At the customer's request (for an additional fee), the manufacturer can equip the trailer with a plate which indicates slow-moving vehicles.

1.4 Transport

The trailer is ready for sale as fully assembled and does not require containerisation. Only the technical and operational documentation of the machine and any additional equipment are subject to packing. Delivery to the user takes place by road transport or after coupling to a tractor by an independent transport unit.



WARNING

WARNING!

The general health-and-safety regulations must be observed when loading and unloading the trailer. The persons operating the loading and unloading equipment must have the required authorisation to use the equipment.

If the trailer is transported on a platform truck it must be fastened by means of belts or tensioning chains equipped with a tensioning mechanism. The fasteners must have a valid safety certificate. Chocks or other parts without sharp edges must be placed under the wheels of the trailer to prevent the machine from rolling. The wedges must be attached to the platform of the means of transport. When loading and unloading, special attention must be paid to avoiding damage to the equipment of the trailer and the paint coating. Belts or fastening chains can be attached to transportation holders welded to the top frame. Rails or other strong frame components can also be used for this purpose. When fastening the machine, special attention must be paid to the correct fixing of the load-carrying body.

Before loading onto the platform, connect it to the tractor's hitch and connect the brake-system lines. The transfer onto a low-floor trailer must be done using unfolded ramps.



WARNING

WARNING!

Pay particular attention to the angle of inclination of the ramps on a low-floor trailer. It should not exceed 10 degrees. Excessive inclination of the ramps can lead to damage, both to the agricultural trailer and the transport trailer.

2. Safety of use

2.1 Obligation to provide information



WARNING

WARNING!

When the trailer is being handed over between users, the Instructions Manual must also be transferred and the person taking over the trailer must undergo training as indicated in the Manual.

2.2 General safety and use regulations

Before each commissioning, the trailer must be checked for safe operation.

- In addition to the information in this Instructions Manual, observe the generally applicable safety and accident-prevention regulations
- The attached symbols, warnings, and information inscriptions provide important guidelines for safe operation – observing them serves your safety
- Operate the trailer only if all essential devices are connected up and protected against unintentional disconnection or opening (e.g. hitch and drawbar, couplings)
- Before starting operations, familiarise yourself with all devices and controls and their functions. It is too late to do this during the operations
- Use of the trailer by persons under the influence of alcohol or other stimulants, and/or who are not trained, and/or do not have appropriate driving licences, are prohibited

2.3 Operational safety

- 1) Before using the product, the user must read and understand the content of this Manual, and observe all instructions in this Manual during operation.
- 2) If the information contained in this Manual is unclear, please contact the retailer running an authorised technical service on behalf of the Manufacturer, or contact the Manufacturer directly.
- 3) Careless and/or improper use and operation of the trailer, as well as failure to observe the recommendations contained in this Manual, pose a risk to health.
- 4) Failure to observe the rules of safe use poses a threat to the health and life of the operators and third parties.
- 5) Please note that there are residual risks, so observing safety rules must be a priority when operating the trailer.
- 6) All safety-related information must also be passed on to all other trailer users.
- 7) Check the immediate vicinity (children, bystanders) before putting into operation. Pay particular attention in the event of reduced visibility.
- 8) When unloading is complete, the load-carrying body must be completely lowered. Never leave the trailer with the load-carrying body raised unattended.
- 9) Accessing the trailer is only possible with the trailer stationary and the tractor engine switched off.
- 10) The raising and lowering of the load-carrying body should always be controlled from the driver's seat.
- 11) Couple the trailer as prescribed and only connect it to the recommended equipment, and secure the drawbar eye with the tractor's transport hitch.
- 12) Special care must be taken when coupling and uncoupling the trailer to and from the

tractor.

- 13) When being installed and removed, any support and safety devices and ladders must always be placed in a position which ensures safe operation.
- 14) Observe the acceptable axle loads, and total mass and transport dimensions.
- 15) Check for the transport-equipment connection and inspection of brakes and lights, marking plate, and other protective devices.
- 16) Before driving, check the function of the lights and brakes and prepare the trailer in accordance with the instructions provided in the section **Driving on public roads**.
- 17) Take account of changes in vehicle behaviour, steering, and braking performance, resulting from the coupled trailer and its load.
- 18) When driving the trailer, the distribution of the load and/or inertia forces should be taken into account, especially if the load is asymmetrical.
- 19) Do not stay within the range of the load to be discharged.
- 20) The hydraulic lifting (tilting) of the load-carrying body may only be started if
 - the trailer is coupled to the tractor
 - the trailer is standing on a hard, flat, surface
 - there is no-one in the unloading area
 - the tractor is aligned with the axle of the trailer
 - a safe distance from power lines is kept
 - there are no strong gusts of wind.
- 21) If it is necessary to unload to the rear on a slope, the tractor and trailer should be positioned in the uphill direction. When side unloading on a slope, the load-carrying body should be tilted to the side opposite the inclination of the trailer.
- 22) For all work with the load-carrying body raised, the body must be secured against falling by means of the trailer's support. Switch off the tractor's engine and remove the key from the ignition switch.
- 23) Take care to avoid crushing fingers and hands when opening and closing the load-carrying body walls.
- 24) Observe the warnings against crushing and shear points when starting the trailer. There is a risk of injury when coupling and uncoupling the trailer to the tractor. For this reason, when coupling and uncoupling the trailer, do not step between the trailer and the tractor, or stand behind the trailer, if it is not secured with wheel chocks or parking brake.
- 25) No person may stand between the tractor and the trailer unless the vehicle is protected against rolling by the parking brake and/or the wheel chocks.
- 26) Secure the trailer and the tractor against rolling when stationary.
- 27) It is prohibited to drive with the load-carrying body raised.
- 28) Keep a safe distance from electrical lines when lifting the load-carrying body. The front wall of the trailer features a pictogram C.2.30., in accordance with PN-ISO 11684:1998 warning about power lines.
- 29) When carrying out repair and maintenance work which requires the load-carrying body to be lifted, the body must be empty and secured by mechanical support against unintentional lowering.
- 30) The driving speed must always be adapted to the ambient conditions. Avoid sudden uphill or downhill turns on sloping terrain.
- 31) Maintain a sufficient safety clearance within the turning area of the unit.
- 32) When reversing, ensure that you have sufficient visibility (with the assistance of another person).

- 33) When cornering, take into account the inertia of the trailer.
- 34) Observe a minimum turning radius of approx. 6 m when turning and reversing.
- 35) The attachment of additional safety devices to the transported load on the trailer (chain, tarpaulin, foil, net, etc.) should only be carried out when the tractor engine is switched off and the ignition key removed.
- 36) Remedy any functional faults in the attached devices only with the engine switched off and the ignition key removed.
- 37) In the event of a failure of the hydraulic or pneumatic systems, the trailer must be taken out of service until the failure has been remedied.
- 38) It is prohibited to carry out maintenance or repair work with a load-bearing, or raised, unsupported, load-carrying, body.
- 39) Before carrying out repair work on the hydraulic or pneumatic systems, the oil or air pressure must be reduced.
- 40) In the event of injuries caused by a strong hydraulic oil jet, consult a physician immediately. Hydraulic oil can penetrate under the skin or into the eye and cause infections.
- 41) Use the hydraulic oil recommended by the Manufacturer. Never mix two types of oil.
- 42) Entering the loading area is only permitted when the drive and the engine are switched off. Remove the key from the ignition.
- 43) Switch off the engine and remove the ignition key before leaving the tractor. Engage the parking brake and secure the trailer with a chock.
- 44) When travelling on public roads, the maximum-allowable trailer load on the axle must not exceed 51.5 kN on the front and rear axle of a T730/1 trailer, 61.3 kN on the front and rear axle of a T730/2 trailer, and 68.6 kN on the front and rear axle of a T730/3 trailer.
- 45) The maximum-allowable pressure in the hydraulic system is 16 MPa.
- 46) The maximum-allowable pressure is 0.63 MPa in a single-line pneumatic system and 0.85 MPa in a dual-line system.
- 47) Preparations of the trailer for use (connecting hydraulic hoses, pneumatic system, etc.) should be made with the tractor engine switched off and the ignition key removed.
- 48) The Manufacturer supplies the trailer fully assembled.
- 49) Hydraulic lines must be replaced every 4 years.
- 50) Noise – ensure the equivalent A-weighted emission sound-pressure level (LpA) is not above 70 dB.
- 51) Keep the trailer clean.

2.4 Tyres



WARNING

WARNING!

When the tyres are in use, it is essential that the trailer is secured against unintentional displacement by means of the parking brake and wheel chocks. The wheels can only be dismantled when the trailer is not loaded.

- Repair work on tyres and wheels should be carried out by skilled persons who are equipped with suitable tools
- Tyres must be protected from sunlight over longer trailer stoppages

- Avoid damaged road surfaces, sudden and alternating manoeuvres, and high speeds when cornering
- The tyre valves must be secured with suitable caps to prevent the penetration of dirt.



The air pressure must be checked regularly. Maintain the recommended air pressure. The correct pressure is indicated on the tyre or as a sticker on the trailer.



WARNING

WARNING!

Check wheel nuts regularly and tighten if necessary.

M18x1.5 = 270 Nm, M20x1.5 = 350 Nm, M22x1.5 = 475 Nm.

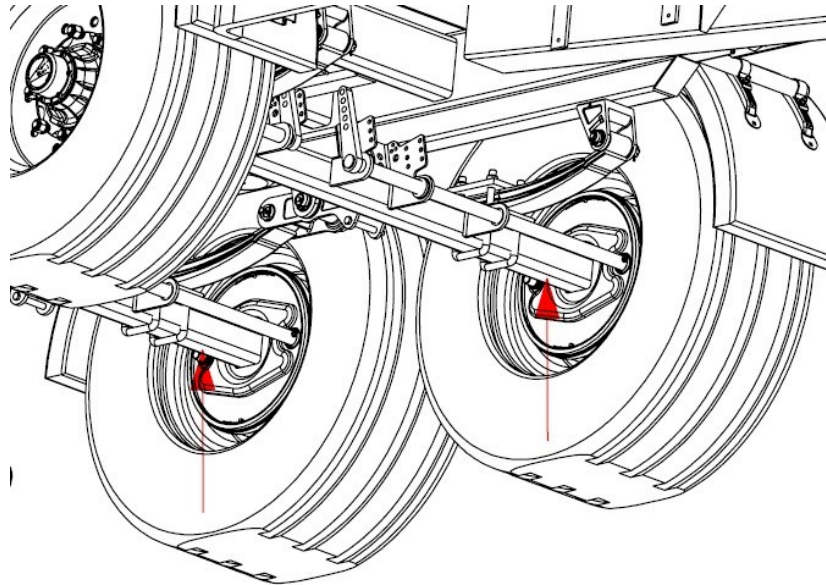

Figure 2. Jack-application point

2.5 Pneumatic system



WARNING

WARNING!

The pneumatic system is under high pressure. Before starting the system working, depressurise the system and switch off the tractor's engine.

- When connecting pneumatic lines to the tractor's pneumatic system, ensure that the valves on the tractor and trailer side are not under pressure
- Check the pneumatic connection on a regular basis, and replace any damaged and ageing parts. Replacement of lines must comply with the manufacturer's technical requirements. Replace flexible lines every five years, unless any damage has been found earlier
- Repair work on the pneumatic system may only be carried out by an authorised representative of the trailer manufacturer.

2.6 Operation and maintenance



WARNING

WARNING!

Carry out any repair, maintenance and cleaning work, as well as any removal of functional faults, with the tractor's drive and engine switched off. Remove the key from the ignition switch.

- Check nuts and bolts on a regular basis in their fixed positions and tighten. Replace ordinary screws only with screws of the same quality and strength as the originals
- When operating underneath a raised and tilted but unloaded load-carrying body, always secure the body against falling with the support provided by the trailer

- When replacing parts, use suitable tools and protective gloves
- When the work is complete, the trailer must be thoroughly cleaned without leaving any residue on the trailer body
- Disconnect the continuous power supply before welding and/or working on the electrical system
- Protective equipment is subject to wear and tear; therefore, it should be regularly adjusted, inspected, and replaced, in good time
- The spray-suppression flaps should be cleaned on a regular basis
- Use only spare parts recommended by the manufacturer
- The trailer should be stored in roofed areas (preferably on a level and hard surface) and in such a way as to prevent injury to people and animals.
- Used parts must be handed over to the appropriate recycling points, while respecting environmental requirements.

2.7 Travelling on public roads



WARNING

WARNING!







Before leaving for public roads, check the correct operation of lights, the brake system, and the completeness of the trailer markings.



- Adhere to traffic regulations when driving on public roads
- Exceeding the permissible load capacity of the trailer can cause damage to the trailer and pose danger to road safety
- Do not exceed the permissible speed of 40 km/h
- Ensure the trailer is suitable for working on ground with a gradient of up to 10o
- When driving on public roads, the trailer should be equipped with a retro-reflective warning triangle, and the bracket located on the rear wall of the trailer should contain a plate indicating slow-moving vehicles, which is an accessory of the tractor
- It is prohibited to leave the loaded trailer on a slope or unsecured against unintentional displacement Protection consists of engaging the parking brake, placing wheel chocks, and fastening the transported load with transport belts
- Transport speed max. 40 km/h.

2.8 Warning/information signs and phrases on the trailer

The warning signs and phrases on the trailer must not be removed. They are intended for the safe handling of the trailer. If the information sticker has been damaged or removed, it must be reordered. Stickers with phrases and symbols can be purchased at service points or from the trailer manufacturer.

Table 2 Safety signs

No.	Safety symbol (mark)	Meaning of the symbol or content of the inscription	Position on the trailer
1	2	3	4
1		Read the Instructions Manual I	On the front crossmember of the load-carrying body frame
2		Switch off the engine and remove the key before maintenance or repair	On the front crossmember of the load-carrying body
3		Keep a safe distance from power lines	On the front crossmember of the load-carrying body
4		Do not reach into the crushing area if the elements can move	On the side panels
5		Before you enter the danger zone, fit a support	On the left-side member of the chassis frame, at the support
6		Riding on the machine itself is prohibited, but you may ride in the passenger seat	On the front wall of the load-carrying body.
7		Keep a safe distance from the machine	On the front wall of the load-carrying body

8		Do not ride on platforms or ladders	On the ladder
9		Crushing of toes or a foot. Force applied from the top	On the drawbar
10		Hooking or lifting point	On the side members of the chassis frame
11		Attention! It is prohibited to carry out control and maintenance work with a load-bearing or raised, unsupported, load-carrying body.	On the support
12		Attention! It is prohibited to stay within the range of the load when being discharged. It is prohibited to climb onto the trailer while it is being driven.	On the front wall of the load-carrying body.
13		"Load capacity 8 T".	On the right and left side of the load-carrying body.
14		"Load capacity 10 T".	On the right and left side of the load-carrying body.
15		"Load capacity 12 T".	On the right and left side of the load-carrying body.
16		Maximum pressure in the hydraulic system - 16 MPa	On the front crossmember of the floor frame.
17		Maximum pressure in the pneumatic system - 0.6 MPa single-line - 0.8 MPa dual-line	On the front wall of the load-carrying body.
18		Maximum tyre pressure	Above the wheels
20		Coupling to the tractor's top hitch only.	On the drawbar



WARNING

WARNING!

The user of the trailer must maintain the legibility of all warning inscriptions and signs attached to the trailer over the whole period of operation. If they are damaged or destroyed, replace them with new ones.

3. Technical specifications, general data

Table 3 The specifications of the T730 agricultural trailer

No.	General information			
1.	Type of vehicle	Agricultural trailer		
2.	Manufacturer	METAL-FACH Sp. z o.o., ul. Kresowa 6216-100 Sokółka		
3.	Type (Model)	T730		
4.	Type of bodywork	Box		
5.	Nameplate Location	Front crossmember		
Dimensions/weights				
		T730/1 – 8t	T730/2 – 10t	T730/3 – 12t
6.	Length, mm	Max.6890	Max.6890	Max.6890
7.	Width, mm	2550	2550	2550
8.	Height, mm (with extension)	1780 (2280)	1880 (2380)	1880 (2680)
9.	Number of axles, pcs	2	2	2
10.	Wheel base, mm	1200	1200	1200
11.	Wheel track, mm	1900	1900	1900
12.	Dimensions of the cargo space			
	- length, mm	4520	4520	4520
	- width, mm	2420	2420	2420
	- height (with extension), mm	500 (1000)	600 (1100)	600(1400)
13.	Elevation of the loading surface, mm	1250	1250	1250
14.	Elevation of drawbar swinging axles, mm	420-850	420-850	420-850
15.	Drawbar-eye diameter, mm	40/50	40/50	40/50
16.	Vehicle ground clearance, mm	430-450	430-450	430-450
17.	Vehicle kerb weight, kg*	3500	3540	3940
18.	Permissible total weight of the vehicle, kg	11500	13540	15600
19.	Maximum contact force, kN			
	- on the axle unit kN	103	122.6	137.2
20.	Permissible load capacity of the vehicle, kg	8000	10000	12000
Suspension				
21.	Type of suspension	Dependent, sprung	Dependent, sprung	Dependent, sprung
22.	Type of spring elements	Longitudinal parabolic springs	Longitudinal parabolic springs	Longitudinal parabolic springs
Wheels and tyres				
23.	Number of wheels, pcs	4	4	4

24.	Wheel-disc size	11.75x22.5	11x18	11.75 x22.5	11x18	11.75 x22.5	11x18
25.	Tyre size and PR number	385/65 r22.5		385/65 r22.5		385/65 r22.5	
26.	Tyre pressure, bar	5-9		5-9		5-9	
Brake system							
27.	Service brake						
	- type	Mechanical, drum brake		Mechanical, drum brake		Mechanical, drum brake	
	- control system	Pneumatic, positive pressure, dual-line system, hydraulic		Pneumatic, positive pressure, dual-line system, hydraulic		Pneumatic, positive pressure, dual-line system, hydraulic	
	- acts on (number of wheels)	4		4		4	
28.	Parking brake						
	- type	Mechanical, drum brake		Mechanical, drum brake		Mechanical, drum brake	
	- control system	Manual, via crossed helical gear		Manual, via crossed helical gear		Manual, via crossed helical gear	
	- acts on	2 front axle wheels		2 front axle wheels		2 front axle wheels	
Electrical system							
29.	Rated voltage, V	12, from the tractor to work with		12, from the tractor to work with		12, from the tractor to work with	
Operating data							
30.	Maximum transport speed, km/h	40		40		40	
31.	Maximum driving speed, km/h	40		40		40	
Additional information							
32.	Other Information						
	- tractor to work with	Min. 58 kw		Min. 66 kw		Min. 73 kw	
33.	Minimum turning diameter	6000 mm		6000 mm		6000 mm	

*Weight can vary, depending on vehicle specification.

4. General structure and operation description

The T730 trailer is a metal structure with an open load area. The trailer is equipped with a pneumatic or hydraulic service brake and a parking brake controlled manually by means of a helical gear acting on the friction elements of the service brake of the rear axle.

The trailer has a complete signalling and warning system (electrical installation and reflectors).

The trailer can also be used for transport on public roads.

The trailer is manufactured in accordance with Directive 2006/42/EC, and the standards PN-EN ISO 4254-1 2009, PN-EN ISO 1853+A1 2009, PN-EN ISO 13857 2010, PN-EN ISO 121002011.

4.1 Chassis

The trailer chassis consists of the following units: bottom frame, drawbar, wheel sets and suspension elements. The bottom frame and the drawbar are made as a welded construction of steel sheets and sections.

The trailer wheel sets consist of the following elements: axles (tandem), running wheels, brakes on running wheels.

The axles are made of thick-walled rod tubes ended with pins, on which the wheel hubs are mounted on tapered roller bearings. These are single wheels equipped with drum brakes with jaws operated by mechanical cam spreaders.

The suspension of the trailer axles is made up of semi-elliptical steel springs attached to the lower frame by means of bolts and sliders. The wheel sets are fixed to the springs with screws.

4.2 Load area

The load area of the trailers is formed by

- 1) The upper frame (frame of the load-carrying body) is mounted on the lower frame (chassis frame) in articulated sockets secured with pins, which are pivot points when tilting the upper frame (load-carrying body).
- 2) Side walls and side extension are individual elements. Each of the elements has a separate set of locks, which allows the closing and opening of individual parts of walls and extensions independently of each other, and in any order. This design increases the functionality of trailers and makes them easier to operate.
- 3) The wall and extension locks are protected against unauthorised opening.

4.3 Hydraulic tilting mechanism of the load-carrying platform

The hydraulic mechanism is used for the automatic unloading of the trailer by tilting the load-carrying body backwards, or to the sides. The hydraulic system of the tilting mechanism is supplied with oil from the tractor's hydraulic system.

The hydraulic system consists of the following: a plug on the coupling valve, hydraulic hoses, a single-acting hydraulic cylinder, and a shut-off valve, as well as fastening and fixing elements. A distributor in the tractor's hydraulic system is used to control the lifting and lowering of the load-carrying body.



WARNING

WARNING!

The shut-off valve limits the tilting angle of the load-carrying body when tilting it sideways. This valve is adjusted by the trailer manufacturer, and it is prohibited for the user to change the settings. Improper adjustment can cause the trailer to tip over.

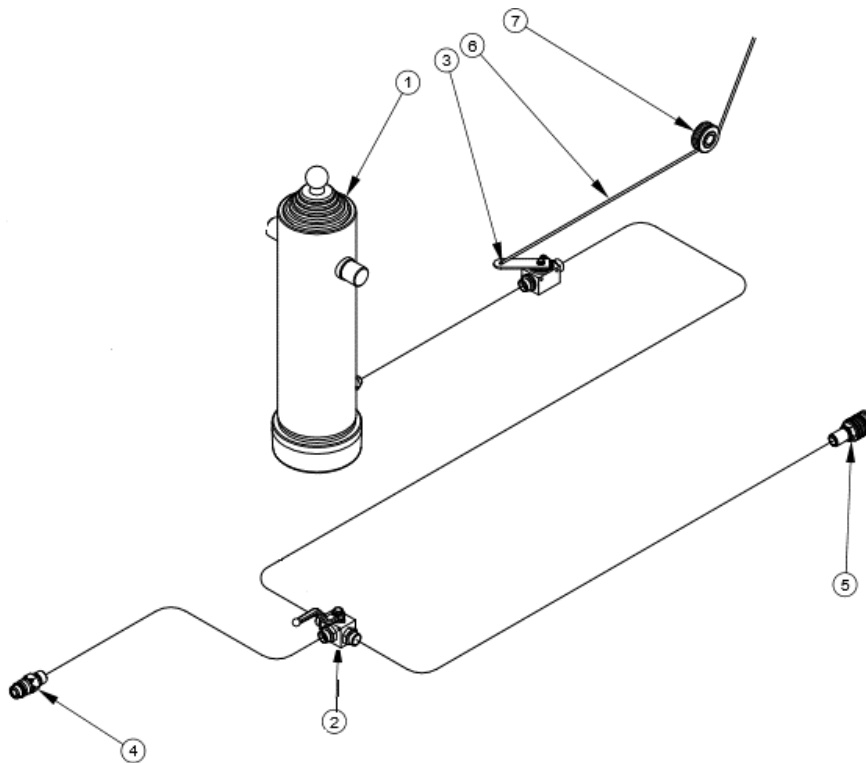

Figure 3. Diagram of the hydraulic system of the load-carrying-body tilting mechanism, 1 - telescopic actuator, 2 - three-way valve, 3 - shut-off valve, 4 - quick-connector - plug, 5 - quick-connector - socket, 6 - steel cord, 7 - roller

4.4 Electrical system (signalling and warning)

The electrical system of trailers is adapted to supply power from a 12V DC power source - from the system of the cooperating tractor.

The diagram of the electrical system and positioning of the trailer lights is shown in Figure 4.



WARNING

WARNING!

During the trailer operation, there is a risk of lightning strike.

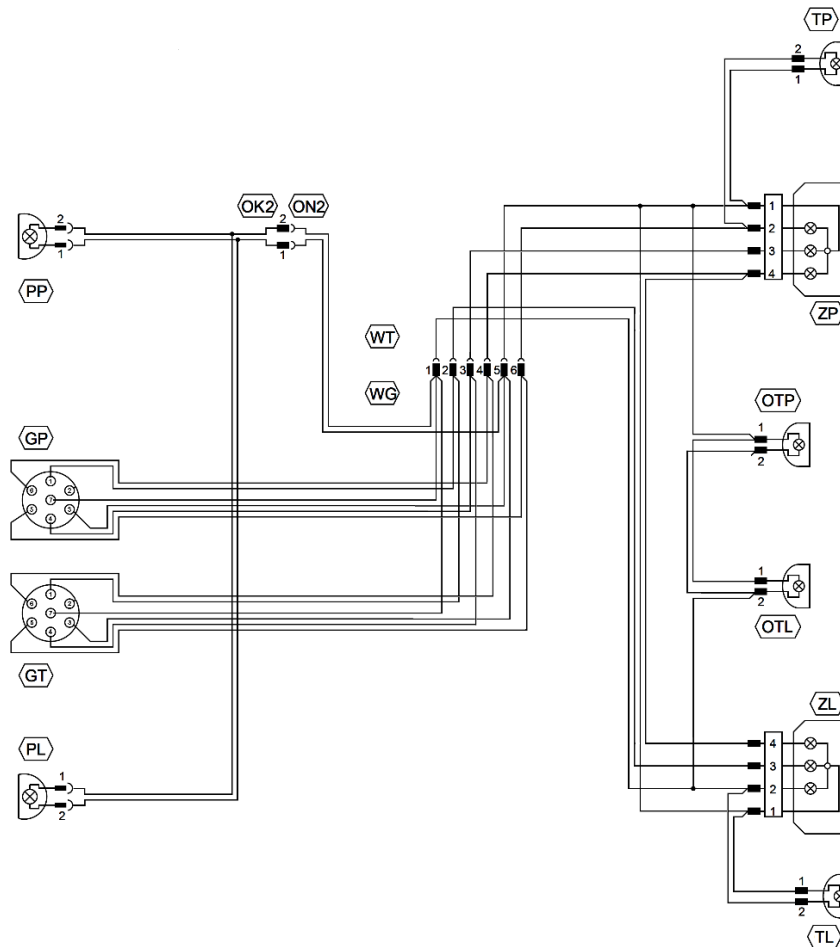

Figure 4. Wiring diagram of the trailer ZP – right-rear composite lamp, ZL – left-rear composite lamp, GP - seven-pin front socket, GT - seven-pin rear socket, OTP - right licence-plate lamp, OTL - left licence-plate lamp, PP – right-front-position lamp, EN – left-front position lamp, TP – right-rear-position lamp, TL – left-rear-position lamp. GT and GP sockets connection marks 31 - ground + power supply, L – left-turn signal, 54 - STOP lamp, 58L – rear-left-position lamp, 58R – rear-right-position lamp, R – right-turn signal

4.5 Brake system

The T730 trailer is equipped with the following brake systems.

- Service brake - pneumatically controlled, dual-line or hydraulic brake acting on all wheels, activated from the driver's seat by pressing the tractor-brake pedal
- Parking brake - mechanically controlled by hand via a crank mechanism and a helical gear located on the left side of the trailer, acting on the wheels of the rear multiple axle.

The design of the service brake ensures the automatic braking of the trailer running wheels in the event of the unforeseen disconnection of the trailer's and tractor's pneumatic system.

Diagrams of the pneumatic dual-line hydraulic brake system are shown in the following drawings.

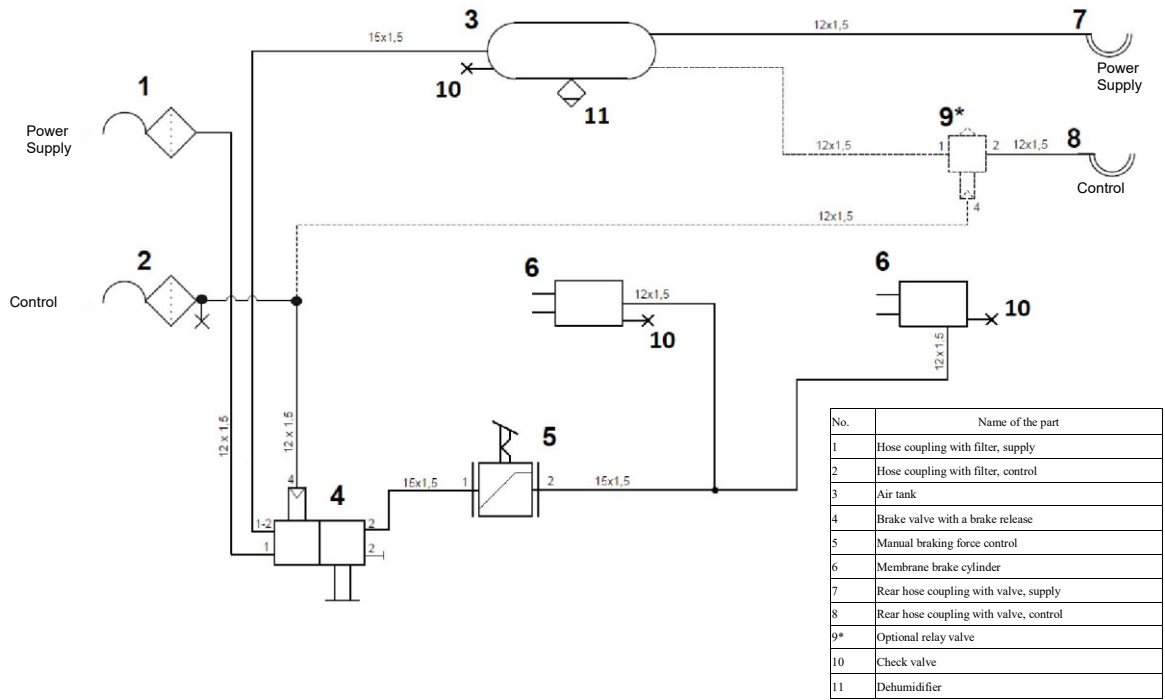

Figure 5. Diagram of the dual-line pneumatic-brake system

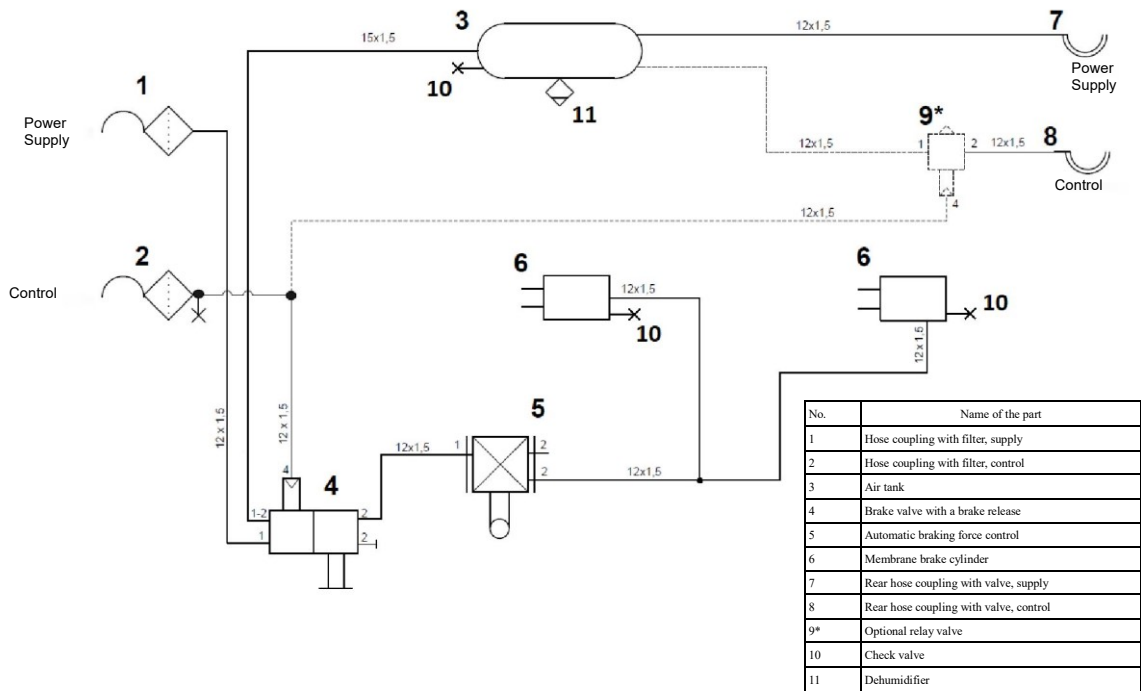

Figure 6. Diagram of the dual-line pneumatic-brake system with automatic braking-force control

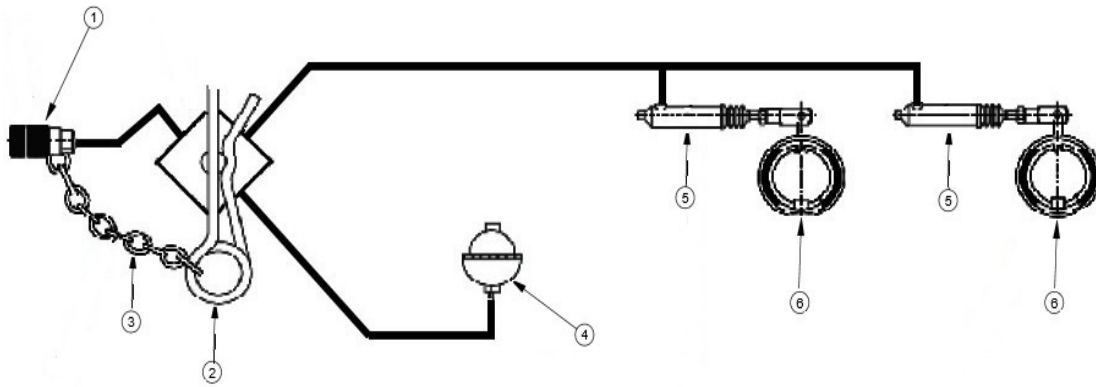

Figure 7. Diagram of the hydraulic brake system 1 – brake connector, 2 – safety valve, 3 – safety-valve chain, 4 – hydraulic accumulator, 5 – hydraulic brake cylinder, 6 – brake drum

5. Storage and sales

5.1 Storage

After the work is finished, the trailer should be thoroughly cleaned and washed with a running-water stream.

The trailer should be protected against direct sunlight and rain, parked on a paved surface on its running wheels with support wedges under the wheel axles (reduce tyre pressure and protect them if exposed to sunlight).

If the trailer is exposed to the weather, check from time to time to ensure that there is no rain in it.

Make sure the paint coat is intact. These areas should be cleaned, degreased, and then covered with paint, maintaining the uniform colour and even thickness of the protective coating.

Long-term storage is permitted only in enclosed or roofed areas.

If the trailer is equipped with a tarpaulin, check on a regular basis to ensure that no water accumulates on its surface. Too much water accumulating on the tarpaulin surface can damage the tarpaulin and its support frame.

5.2 Purchasing the Trailer



WARNING

WARNING!

When choosing a trailer, the buyer should check whether the trailer is complete, undamaged, fully equipped with basic equipment, the serial number is stamped on the nameplate, and whether this data corresponds to the data on the warranty certificate, and the warranty is completed correctly in accordance with the identification data given on the nameplate.

The buyer must take the trailer from the manufacturer or from the point of sale, or agree the terms of delivery with the manufacturer.

The trailer is sold as fully assembled, ready for operation, with the basic equipment as specified in section 1.3 of this manual. Additional equipment may be purchased for an additional fee.

The point-of-sale staff are obliged to acquaint the buyer with the rules of the construction and operation of the trailer, safety requirements, and warranty conditions.

6. Information on use

6.1 First start-up of the baler



WARNING

WARNING!

Use only a functioning tractor with functioning brake, electric and hydraulic systems, and a functioning transport hitch of sufficient strength.

Before starting the trailer for the first time

- familiarise yourself with the names and locations of the individual trailer units/elements,
- check trailer's tyre pressures,
- couple the trailer to the tractor
 - position the drawbar eye of the trailer at the height of the tractor's transport hitch,
 - couple the drawbar eye with the tractor hitch,
 - secure the hitch pin against falling out,
 - switch off the tractor's engine,
 - engage the tractor's parking brake,
 - connect the pneumatic and electrical systems to appropriate sockets on the tractor,
- check the operation and tightness of the pneumatic, hydraulic, and electrical, systems of the trailer and tractor,
- check all devices, their connections, and protection against undesired disconnection or displacement,
- switch off the trailer's parking brake.

Perform these activities every time you start the trailer.

6.2 Loading the load-carrying body

The load-carrying body may only be loaded when the trailer is coupled to a tractor, parked on level ground, and with the drawbar in the straight-ahead position.

The use of mechanical loading devices (crane, loader, conveyor, etc.) is desirable for loading.

Before loading, check that the wall and extension locks are closed.

When loading the trailer, the load should be distributed evenly over the entire surface of the load-carrying body. When transporting materials exerting point pressure on the floor of the body (concentrated loads, e.g. large stones), thick boards should be placed on the floor before loading. This will effect a smaller surface load on the floor and protect it against damage.

For transporting bulk materials, use the wall extensions of the load-carrying body, and for transporting materials protruding beyond the trailer's contour planes, road-traffic regulations must be observed and the protruding load must be marked accordingly.



WARNING

WARNING!

It is prohibited to exceed the permissible load capacity of the trailer and the permissible axle loads, as this threatens road safety and can cause damage to the trailer.

The transported load must be protected against displacement, the generation of excessive noise, and road spillage.



WARNING

WARNING!

It is prohibited to transport people on the trailer.

The table below shows the approximate weights of selected goods.

Table 4 Approximate weights of goods

Approximate weights of selected goods 1m³ in kg	
Soil	1600 – 1800
Wheat	710 – 820
Rapeseed	700 – 750
Potatoes	625 – 725
White beet	650 – 700
Legumes	760 – 820
Construction aggregates	1400 – 1850
Lime	900 – 1500
Hard coal	1200 – 1600

6.3 Driving on public roads

Before leaving for a public road, in addition to the activities listed in section 6.1, you should

- equip the trailer with a plate indicating slow-moving vehicles;
- check that the transported cargo is protected against displacement and falling out on the road;
- check that the load does not exceed the permissible load capacity or axle load.



WARNING

WARNING!

Observe the applicable road-traffic regulations.

During the first hours of brake operation, the drum shoes adapt to the brake drums. The total braking effect is achieved after the friction phase of friction parts.

6.4 Unloading

The load-carrying body may be unloaded manually, mechanically or by means of a hydraulic tilting mechanism.

Unloading the trailer by tilting the load-carrying body must be performed in the following order:

- align the tractor and trailer on the longitudinal axis
- engage the parking brake of the tractor
- remove the pin connecting the load-carrying body to the chassis frame from the opening (Figure 8)
 - when unloading to the rear – the pins (fig.8) must remain in the rear cups of the body
 - when unloading to the left – the pins must remain in the left-hand cups
 - when unloading to the right – the pins must remain in the right-hand cups
- check that the pins on the unloading side of the trailer are correctly fitted
- open the load-carrying body-wall locks on the unloading side, and release the connecting wire of the sides
- make the load-carrying body tilt using the hydraulic-system cylinder
- after the load has slipped down, lower the body and close the wall(s) using locks.



WARNING

WARNING!

Before starting to unload the trailer by tilting the load-carrying body, it is essential to check that the pins on the correct side of the trailer body have been removed. Failure to remove the pins can damage the trailer.



WARNING

WARNING!

If it is necessary to unload the trailer on a sloping terrain, it is permissible to tilt the load-carrying body upwards (tractor with the trailer facing upwards).



WARNING

WARNING!

No-one may be in the vicinity of the tilting load-carrying body or within the range of a slipping-down load.



WARNING

WARNING!

Do not uncouple the trailer from the tractor when the load carrying-body is raised.

Opening the top lock on the load carrying body wall requires the handle to be moved upwards while pressing the button located under the handle. Opening the lower wall-section locks requires the locks' central lever to be moved.

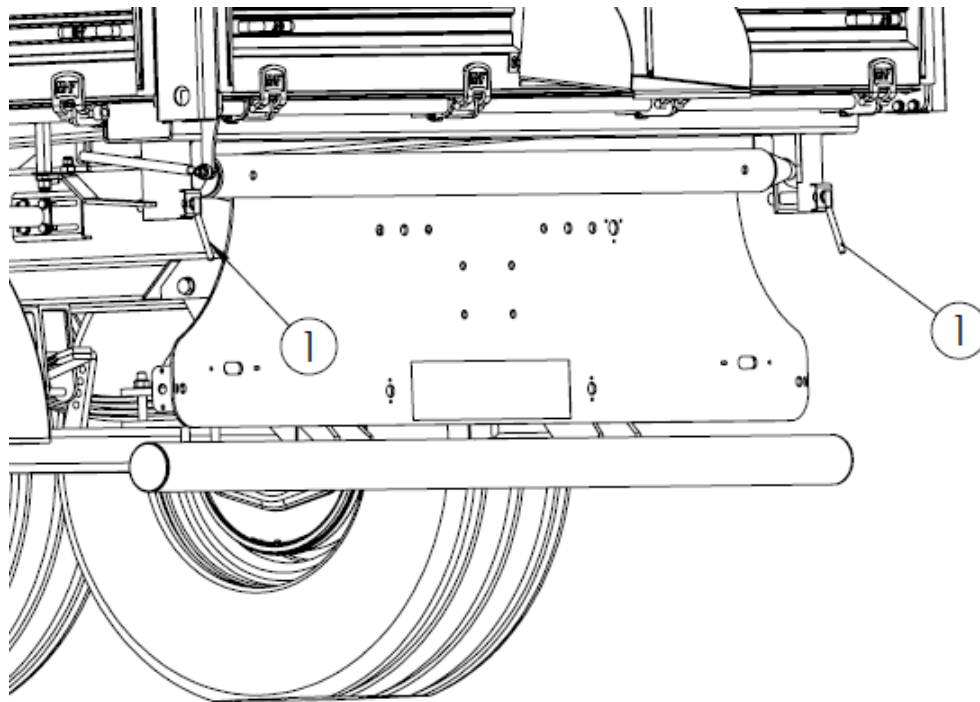

Figure 8. Tipping safety pins

After the load has been unloaded from the trailer, it is necessary to

- lower the load-carrying body and remove any residual material
- fit and secure the pins connecting the load-carrying body to the chassis frame
- lock the wall(s) and prevent it/them from opening automatically
- secure the sides with fastening wire.

6.5 Coupling and uncoupling the trailer with/from the tractor



WARNING

WARNING!

Be particularly careful when coupling the trailer.



WARNING

WARNING!

Only connect the trailer to a tractor equipped with a drawbar which transmits a vertical load of at least 20 kN (2000 kg).



WARNING

WARNING!

The maximum angle between the longitudinal axis of the tractor and the longitudinal axis of the aggregated trailer must not exceed 45°.

Before coupling the trailer, make sure that both machines are fully operational

- before coupling the trailer, make sure that the oil in the tractor's external hydraulic system can be mixed with the hydraulic oil of the trailer
- when coupling the trailer, use a suitable tractor hitch
- having coupled the machines, check the safety device of the hitch
- if the tractor is equipped with an automatic hitch, make sure that the coupling operation has been completed
- no-one may be between the trailer and the tractor during the coupling process.

The trailer is equipped with a hydraulic support foot. When coupling the trailer, connect the supply line (pos. 2 in Fig. 9) and the return line (pos. 3) to the tractor's external hydraulic system.

To uncouple the trailer from the tractor, perform the following steps

- after stopping the tractor and the trailer at the point where the trailer is to be left, engage the tractor's parking brake and place wheel chocks;
- engage the parking brake of the trailer;
- if the trailer is on uneven or sloping ground, it must be additionally secured against rolling down
- disconnect the electrical, hydraulic and pneumatic lines from the tractor
- using the hydraulic support foot, set the eye of the trailer's drawbar in such a position that it is not supported by the tractor's hitch, and its position allows the trailer to be coupled later without the use of the support foot
- with the drawbar eye at the correct height, close the shut-off valve (pos. 4)
- unlock and remove the pin of the drawbar, thereby uncoupling the drawbar from the hitch, drive the tractor away, and insert the pin into the drawbar.



WARNING

WARNING!

When uncoupling a loaded trailer, in addition to the hydraulic foot, support the trailer on an additional base.

Do not use materials which can crack under load (brittle materials, etc.) to support the trailer.



WARNING

WARNING!

Only the trailer left on the hydraulic foot can change its position.



WARNING

WARNING!

Do not uncouple the trailer from the tractor

- if the load-carrying body is raised
- if the trailer is not secured against rolling.



Figure 9. Hydraulic foot. 1- foot, 2 - supply line, 3 – oil-return line, 4 - shut-off valve

7. Service activities

7.1 Instructions for using trailer components which require adjustment

For proper operation, the T730 trailer requires the following adjustments

- adjustment of wheel-bearing play
- adjustment of brake-system components.

7.1.1. Wheels – bearing-play adjustment

In a newly purchased trailer, at the beginning of use (after the first approx. 100 km) and then in the course of operation (after another 1500-2000 km) – check, and, if necessary, adjust the play on the wheel bearings.

Procedure

- connect the unloaded (empty) trailer to the tractor and engage the parking brake of the tractor
- lift one side of the trailer so that the wheel does not touch the ground, and secure it against lowering
- if the wheel shows excessive play, remove the hub cover and the securing pin to prevent the castellated nut from unscrewing itself
- while turning the wheel, simultaneously tighten the castellated nut until the wheel brakes completely
- unscrew the nut by 1/6-1/3 of a turn until the nearest groove overlaps the pin with the hole on the hub spigot
- secure the nut with a new pin, replace, and fasten the hub cover.

If the bearing play is adjusted correctly, the wheel should rotate freely, without stoppage or evident resistance (other than friction of the brake shoes against the drum). Slight friction of the shoes against the drum, particularly in a new trailer or after brake replacement, is a common occurrence. The correct adjustment of the bearing play must ultimately be verified after a few kilometres by hand to check the degree of heating of the hubs. In addition to the improper adjustment of bearing play, considerable resistance to wheel rotation and hub heating can be caused by impurities in the lubricant or bearing damage. The above symptoms require the disassembly of the wheel hub and the rectification of the malfunction.



WARNING

WARNING!

Observe the following when lifting the wheel of the trailer

- couple the trailer to the tractor, position on flat ground and engage the parking brake of the tractor
- place safety chocks under the wheel which is not lifted
- place a jack under the axle close to the raised wheel and lift the wheel so that it does not touch the ground
- secure the wheel against lowering by placing a stand of the appropriate height under the axle.

**WARNING****WARNING!**

- It is essential to check the play and condition of the running-axle bearings after the first month of use, and then regularly at least every 6 months.

**WARNING****WARNING!**

Use only high-quality bearing grease.

- Never drive without the hub cover, as penetrating dirt (sand) will damage the wheel bearings.

7.2 Brakes

7.2.1 Brakes – servicing the pneumatic-brake system

When operating the trailer, inspect for leaks, check the condition of the brake-system components and connections, and periodically remove water condensate from the air tank.

The tightness of the system must be checked at the nominal system air pressure of 850 kPa for the dual-line system. Leakage is identified by characteristic hissing or the appearance of air bubbles (after flooding with water and soap), in places where compressed air will penetrate outside. If leaks are caused by damaged seals or lines, or other components (e.g. valves, actuators, etc.), replace them with new ones.

The removal of water from the tank is effected by the sideways tilting of the stem of the drainage valve, with normal pressure in the tank. In addition, once a year before the winter season, the drainage valve should be unscrewed and cleaned of any dirt accumulated in it.

7.2.2 Brakes – adjustment of the pneumatic-brake system components

When operating the trailer, check the condition of the brake-system components, and connections, and lubricate the controls periodically.

Adjust the brakes when

- due to the wearing out of the brake shoes, excessive play occurs between the brake lining and the drum, and the brake performance is reduced
- the wheel-brakes action is not simultaneous and not equal.

If the brakes are adjusted correctly, the braking force (the sum of the braking forces at the periphery of the braked wheels) must be a minimum of 30% of the trailer's permissible total weight when braking with the service brake, and the braking force (the sum of the braking forces at the periphery of the braked wheels) when braking with the parking brake must be a minimum of 16% of the permissible total weight of the trailer. Both wheels on the same axle should brake evenly, and the difference in braking forces between the left and right side of the trailer must not be greater than 30%, taking into account that 100% is the greater force.

Place the trailer so that the rear wheels rotate freely. Then loosen nut 4 so that arm 2 can change position in relation to shaft 1. With this position of shaft 1 in relation to arm 2, tighten counter nut 4 when turning the wheel gives a feel of the brake shoes' rubbing against the drum. Repeat for the second wheel.

If the adjustment of the friction components is carried out correctly, the wheel should

rotate freely, without stoppage or evident resistance resulting from friction by the brake shoes against the drum. Slight friction of the shoes against the drum, particularly in a new trailer or after brake replacement, is a common occurrence.

Having made the adjustments as specified above, check and adjust the parking brake as required. Adjust the parking brake by adjusting the length of the cord connecting the expander-cam roller lever with the activating device. The required sum of the braking forces must be obtained at the maximum force on the manual crank of the device of 40daN (with the right angle maintained formed by the cord and expander cam-roller lever).



WARNING

WARNING!

Check the brake system on a regular basis before starting to travel

- operation, tightness and play – adjust or repair, if necessary.



WARNING

WARNING!

Check the brake shoes at least once a year and replace worn linings with new ones.

- In order to achieve the required efficiency - after replacing the friction elements - remember to bed in (by driving with frequent braking) and then adjust them.



Figure 10. Brake-system components

1- shoe spreader shaft, 2 – spreader-shaft lever (arm), 3 - arm adjustment "comb" on the spreader shaft, 4 - tie (push) rod connecting the piston rod of the pneumatic actuator to the spreader shaft arm, 6 – parking-brake line.

7.2.3 Brakes – servicing the hydraulic-brake system

When operating the trailer, inspect for leaks, and check the condition of the brake-system components and connections.

The tightness of the system must be checked at the nominal system pressure of 140 bar. An oil leak is a sign of leakage. If leaks are caused by damage to seals, lines, or other components (e.g. valves, actuators, etc.), replace them with new ones.



WARNING

WARNING!

- During operation, brake drums can heat up to high temperatures.

7.2.4 Hybrid Hydraulic brakes – elements of operation

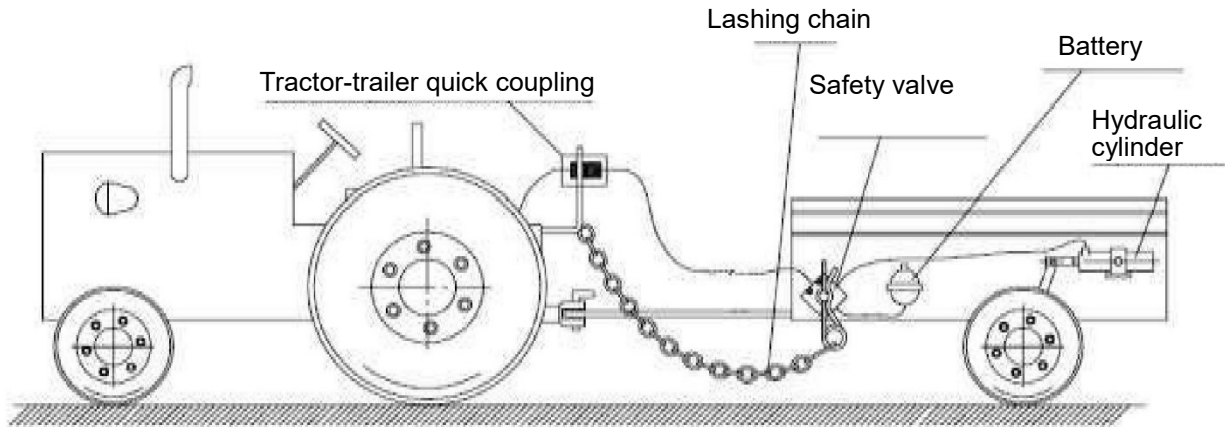

Figure 11. Hydraulic-brakes operation elements – trailer coupled

Figure 11 shows a correctly coupled trailer with a hydraulic brake system. In addition to hydraulic quick connectors, a lashing chain is connected to engage the safety valve. The lashing chain tightens and switches the safety valve to the brake-system engagement state.

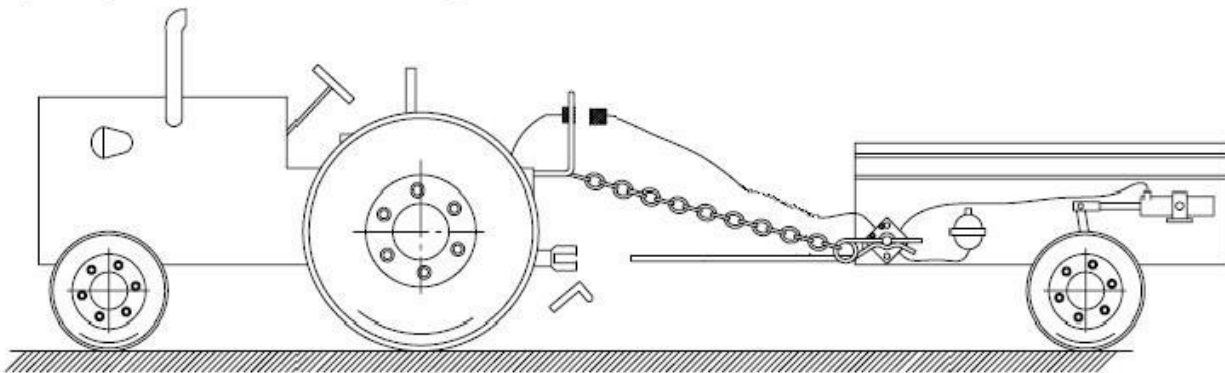

Figure 12. Hydraulic-brakes operation elements – trailer uncoupled

With the use of hydraulic quick coupling, the system can be disconnected without causing damage to the system.

When uncoupling the trailer, the lashing chain tightens, thus switching the safety valve. The brakes of the trailer begin to operate under pressure from the battery.

The tractor is uncoupled from the trailer and the quick coupling protects against oil leakage.

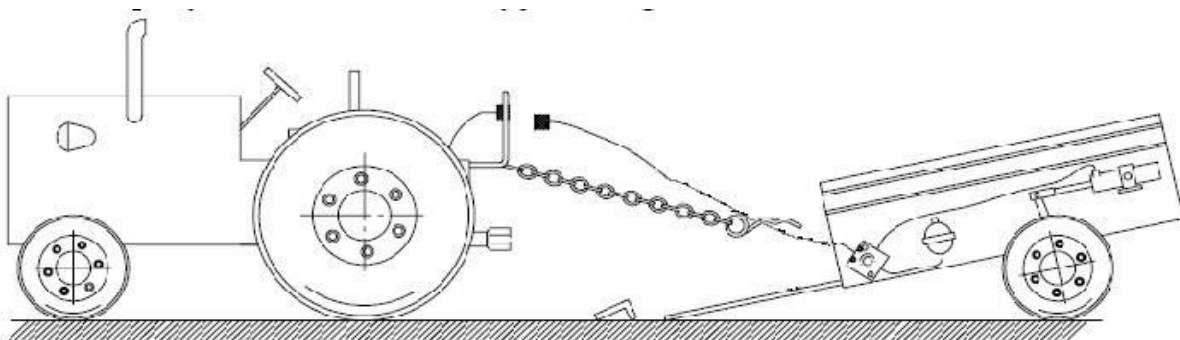

Figure 13. Hydraulic-brakes operation elements – actuating the safety valve

The brake system has not been damaged in any way and can be restored to its original state at any time.



WARNING

WARNING!

Check the wheel nuts on a regular basis (condition and tightness before each use of the trailer), and tighten if necessary.

Tightening torque of nuts for threads

- M18x1.5 = 270 Nm, M20x1.5 = 350 Nm, M22x1.5 = 475 Nm.



WARNING

WARNING!

After the first journeys with a load, and every 100 km, check the tightness of the wheel nuts, and tighten if necessary.



WARNING

WARNING!

Check the tyre air pressure. The correct pressure is indicated on the tyre or on a sticker near the wheel. This is the pressure for the maximum load capacity for transporting at maximum speed.

7.3 Wheels – tyres

Servicing the tyres consists of checking the condition by visual inspection and checking the internal pressure. It is also important that the tyres do not have visible cracks which expose or damage their carcass, and that the hubs, wheel discs, and their attachments, are in good condition.



WARNING

WARNING!

When driving in curves and reversing, the angle between the longitudinal axle of the tractor and the longitudinal axle of the trailer must not exceed 45 degrees. Failure to observe this can result in damage to the wheels and axles.

7.4 The hydraulic system

7.4.1 The hydraulic system – the operation of the hydraulic tilting system of the load-carrying body



WARNING

WARNING!

Check that the oil in the hydraulic system of the trailer and oil in the tractor's external hydraulic system are of the same type and grade. The use of different oil grades is not permitted.



WARNING

WARNING!

Hydraulic oil can heat up to high temperatures during operation.

The hydraulic system of the trailer must be completely leak-proof. The tightness of the hydraulic system must be checked with a several-second overload of the system by tilting the load-carrying platform to the rear. Tighten the couplings if there is a leakage of oil in the hydraulic hose lines. If this does not remove the fault, the line or coupling elements must be replaced with new ones. If there is an oil leakage outside the coupling, the leaking component of the hydraulic system must be replaced.

Any mechanical damage to the component qualifies it for replacement with a new one. The condition of the hydraulic system should be monitored on an ongoing basis while the trailer is in use. Observe the required cleanness of the connecting fittings when connecting the hydraulic systems of the trailer and tractor.



WARNING

WARNING!

Required cleanness of the 20/18/15 hydraulic oil in accordance with ISO 4406-1996.



WARNING

WARNING!

Inspect the hydraulic system on a regular basis every 6 months. Inspect the condition of the hydraulic lines.
Replace even undamaged hydraulic lines every 4 years.

7.4.2 The hydraulic system – adjusting the hydraulic tilting mechanism of the load-carrying body

The hydraulic system is equipped with a safety cord (the load-carrying body tilt-angle limiter) and an oil shut-off valve to the hydraulic cylinder when tilting the load-carrying body. For safety reasons, it is prohibited for unauthorised persons to make adjustments or to remove the limiters. The purpose of the shut-off valve is to cut off the oil supply to the cylinder before

the load-carrying body reaches the maximum (permissible) tilt angle. Changing the length of the cord connecting the frame of the body to the shut-off valve or its breaking can result in damage and make the trailer overturn.



WARNING

WARNING!

It is prohibited to adjust the cord of the shut-off valve controlling the tipping angle of the load-carrying body, or to disconnect it. Improper adjustment of the tipping angle of the load-carrying body can make trailer overturn.

8. Faults and troubleshooting

The table below shows the faults, their causes (symptoms), and methods for rectifying them.

Table 5 Failures

No.	Type	Cause	Method of rectification
1.	2.	3.	4.
1.	Excessive heating of brake drums.	Brake shoes are not adjusted correctly.	Adjust in accordance with section 7.2.2.
2.	Excessive heating of the wheel hub.	Too little play on bearings. Dirty bearing grease.	Adjust in accordance with section 7.1.1. Remove the hub, replace the grease, and adjust the bearings, as above.
3.	Lubricant flow onto brake shoes.	Hub seal worn, damaged or incorrectly installed.	Remove the hub, replace the worn or damaged seal, and install a new one correctly. Remove the grease from the shoes and the drum, wash the friction elements in the extraction gasoline, install the hub, and adjust the bearings as above.
4.	The wheels brake unevenly.	Shoe linings or brake shoes are dirty, worn or incorrectly adjusted.	Check the condition of the brake linings, remove any dirt, replace any worn brake linings and adjust in accordance with section 7.2.2.
5.	Insufficient braking performance of the wheels.	Incorrect adjustment of brake shoes and brake controls.	Adjust brake shoes and controls in accordance with section 7.2.2.
6.	Leakage of oil from the hydraulic line joints.	Insufficient tightness in the joints or damage to the seals on the joints.	Tighten, and, if necessary, replace the line elements.
7.	Leakage of oil from the shut-off valve or cylinder.	Worn or damaged seals or mechanical damage to these devices.	Replace seals or complete units (assemblies).
8.	The locking pin of the box does not enter the socket.	Bent pin or dirt between pin and housing.	Replace the pin or clean the pin and housing, apply a thin layer of solid grease to the pin, insert into the socket, and secure.
9.	The seat of the load-bearing platform support does not fit the spigot of the chassis frame.	Bent chassis frame, bent body frame, or mechanical damage to connecting parts.	Contact the manufacturer to replace damaged components.

9. Periodic maintenance

9.1 Lubrication

Proper lubrication is one of the most-important factors which determine the efficient operation of individual trailer assemblies and mechanisms.

Compliance with the manufacturer's lubrication recommendations significantly reduces the possibility of damage or the early wear and tear of individual parts.

Lubrication must be carried out in accordance with the following rules

- the grease must be cleaned before being pumped into the grease nipple
- the grease should be pumped until fresh grease appears in the slots (through which the used grease is squeezed out during pumping)
- after lubrication, leave some grease on the grease-nipple head
- threaded connections, lever connections, and similar trailer elements, should be lubricated with oil
- regularly check wheel-hub-bearing lubrication, refill or replace the bearing grease
- when replacing the grease, remove the hub, remove the used grease, evaluate the condition of the bearings (replace if necessary), and after applying fresh grease and assembling the hub, adjust the bearing play.



Use only high-quality grease.

WARNING

Table 6 Lubrication points

Lubrication point	Lubricant grade	Lubrication interval
Wheel-hub bearings	ŁT 43	Every 6 months
Hydraulic cylinder-head socket	Graphite grease	Every 6 months
Elements of the load-bearing body tilting system	ŁT 43	Every 6 months
Ring hitch	ŁT 43	Every 6 months

9.1.1. Other lubrication points

- 1) Lubricate the moving parts of locks, hinges, and articulated joints, on a regular basis;
- 2) Use a lubricator to press in the grease to the grease nipples;
- 3) Lubricate the moving brake parts (levers and pins) on a regular basis;
- 4) The brake-shoe axle bearing is lubricated with a very-small amount of grease, if necessary;
- 5) Lubricate the wall-locking system and hinges on a regular basis.

9.2 Technical-service activities

The transport capacity, as well as the long service life of agricultural trailers, can only be achieved if it is handled properly and used rationally, within the limits of its structural and

functional parameters.

Minor negligence in the operation of the trailer can have serious consequences. A fault revealed on time can be removed easily with minimal cost and effort, and with maximum results.

Faults in the trailer can be detected quickly only if there is continuous periodic cleaning and careful inspections.

It is therefore necessary to wash the trailer frequently to be able to notice possible damage and malfunctions.

The trailer must also be subject to periodic technical inspection. Lubricate the trailer in accordance with the lubrication instructions.

It is advisable to store the trailer in a roofed area in order to protect it against changing weather conditions and their destructive influence.

In order for a trailer to operate properly, it must be maintained, repaired on time, and monitored with great care during operation.

The daily maintenance (before starting work) of the trailer requires a minimum of work to be done, i.e

- checking the tightness of the bolted parts and protecting them against undesired loosening
- controlling the play of mechanisms and articulated connections
- checking the tightness of the hydraulic system and remove any leaks
- checking the tightness of the pneumatic system
- checking the proper operation of the mechanisms
- checking and performing lubrication as specified in the instructions
- checking pressure in the tyres
- checking wall locks - whether they are properly locked and secured
- when working with wall extensions - checking whether they are operating properly and not posing a threat to traffic and operator safety
- checking the function of the brake and signalling systems.

9.3 Repair instructions

When carrying out minor repairs due to accidental faults, they should be performed with attention to cleanness, the correct installation of all parts, and making the adjustments indicated, which are necessary for the proper operation of the trailer.

Minor repairs during operation (in the field) must be carried out on site by the operator.

Parts dismantled during repair must be stored and protected against dust or other contamination. Special attention must be paid to the protection and cleanness of the bearings.

During repairs in field conditions, cleanness should be maintained when assembling parts (in particular, parts which have fallen to the ground should be washed or at least cleaned of impurities to an extent which allows proper operation).

A series of technical rules for the disassembly and assembly of parts and subassemblies must be observed during current and comprehensive repairs, thus ensuring the quality and efficiency of work.

After each repair of the trailer mechanisms, their operation should be checked.

9.4 Metrical bolt-tightening torques

Optimised tightening torque values for bolts or screws and nuts [Nm] are shown in Table 7.

Table 7 Bolt-tightening torques

Bolt-tightening torques - metrical bolts in Nm							
Size Ø mm	Pitch mm	Bolt version - strength classes					Wheel nuts, wheel bolts
		4.8	5.8	8.8	10.9	12.9	
3	0.50	0.9	1.1	1.8	2.6	3.0	
4	0.70	1.6	2.0	3.1	4.5	5.3	
5	0.80	3.2	4.0	6.1	8.9	10.4	
6	1.00	5.5	6.8	10.4	15.3	17.9	
7	1.00	9.3	11.5	17.2	25	30	
8	1.25	13.6	16.8	25	37	44	
8	1.00	14.5	18	27	40	47	
10	1.50	26.6	33	50	73	86	45
10	1.25	28	35	53	78	91	
12	1.75	46	56	86	127	148	
12	1.50						80
12	1.25	50	62	95	139	163	
14	2.00	73	90	137	201	235	
14	1.50	79	96	150	220	257	140
16	2.00	113	141	214	314	369	
16	1.50	121	150	229	336	393	220
18	2.50	157	194	306	435	509	
18	1.50	178	220	345	491	575	300
20	2.50	222	275	432	615	719	
20	1.50	248	307	482	687	804	400
22	2.50	305	376	502	843	987	
22	2.00						450
22	1.50	337	416	654	932	1090	500
24	3.00	383	474	744	1080	1240	
24	2.00	420	519	814	1160	1360	
24	1.50						550
27	3.00	568	703	100	1570	1840	
27	2.00	615	760	1200	1700	1990	
30	3.50	772	995	1500	2130	2500	
30	2.00	850	1060	1670	2370	2380	

10. Scrapping the trailer

If the user decides to scrap the trailer, the whole trailer should be handed over to the nearest scrap yard designated by a local authority. A certificate obtained from this facility is the basis for the deregistration of the trailer. Any redundant parts or parts after repairs must be handed over to a secondary raw-materials-collection facility.

11. Residual Risk

11.1 Residual-risk description

Although METAL-FACH in Sokółka takes responsibility for the design and structure in order to eliminate hazards, some risk elements are unavoidable while the trailer is in operation.

The residual risk is due to inappropriate actions by the trailer operator, e.g. due to carelessness, ignorance, or improper behaviour. The following prohibited actions create the highest level of risk.

- 1) The operating of the trailer by minors and persons who are not authorised to drive a tractor, as well as persons who are not familiar with the Instructions Manual.
- 2) The operating of the trailer by persons who are sick or under the influence of alcohol or other intoxicating substances.
- 3) Using the trailer for purposes other than those described in the Instructions Manual I.
- 4) Standing between the tractor and the trailer while the tractor engine is running.
- 5) Bystanders, children in particular, standing close to the running trailer.
- 6) Cleaning the trailer during operation.
- 7) Manipulating within the tractor drive train and trailer moving parts during operation.
- 8) Checking the technical condition of the trailer during operation.

When specifying the residual risks, the trailer is interpreted as a machine which was designed and made in accordance with the state of art in the year of its manufacture.

11.2 Residual-risk Assessment

By observing the recommendations such as

- 1) Adhering to the safety rules described in the Instructions Manual I
- 2) Reading the Instructions Manual carefully
- 3) Avoiding reaching into dangerous and prohibited places with your hands
- 4) Avoiding operating the unit in the presence of bystanders, children in particular
- 5) The trailer's being maintained and repaired by properly trained persons only
- 6) The trailer's being operated only by persons who have been trained and know the Instructions Manual I
- 7) Protecting the trailer against access by children

it is possible to eliminate residual risk associated with trailer operation without any risk to people and the environment.



WARNING

Failure to comply with the instructions and guidance provided herein can result in residual risks!

WARRANTY TERMS

1. The manufacturer hands over the trailer designed and made in accordance with the standards currently in force. The manufacturer guarantees that the supplied trailer is free from any manufacturing faults.
2. Metal-Fach Sp. z o.o. provides for the trailer the guarantee period service during 24 months counted from the date of the first sale, with its use as intended, complying at the same time with the recommendations included in this instruction.
3. The proof of providing the guarantee by the manufacturer is the guarantee card correctly filled in by the dealer with the customer signature, confirming acceptance of the guarantee terms.
4. The quality guarantee covers the faults of the machine caused by its faulty manufacturing, material faults, and concealed defects.
5. The guarantee does not cover the units and parts subject to normal operation wear and tear.
6. The guarantee does not cover mechanical damages and damages resulting from the incorrect operation, incorrect maintenance, and incorrect setting of the trailer.
7. The guarantee does not cover damages resulting from the incorrect storage of the machine.
8. The loss of the guarantee results automatically from self-performed modifications by the user.
9. The manufacturer is not liable for any loss, damage, or destruction of the product resulting from causes other than the inherent faults of the supplied machine.
10. During the guarantee period the manufacturer must perform all guarantee repairs of the faults caused by the manufacturing plant, except for the faults mentioned in items 5 to 8.
11. Warranty repairs will be performed within 14 working days from the date of considering the complaint or at any other time agreed by both parties.
12. The repairs performed by the service points in the guarantee period which are not covered by the guarantee must be fully paid for. Prior to carrying out such a repair the service point must agree on its performance with the user, the proposing of the scope of the repair, its planned costs, and time of implementation.
13. The decision of paid repair implementation by the authorised service point of the trailer, which at the time of reporting the repair is within the guarantee period, is taken by the customer.



The current information concerning the products is available on the website www.metalfach.com.pl



GUARANTEE CERTIFICATE

Metal-Fach sp. z o.o.
ul. Kresowa 62
16-100 Sokółka

.....
(Name of the machine)

Guarantee services on behalf
of the manufacturer are rendered by _____

Filled in by the Seller

Manufacturing date _____

Factory number _____

Date of sale _____

Seller's signature _____

Buyer's full name

Address _____

Buyer's signature _____

REPAIRS UNDER GUARANTEE

No.	Date of breakdown remedy	Description of performed actions and replaced parts	Guarantee period of the indicated part extended by	Seal and legible signature

NAME AND ABBREVIATION INDEX

BHP - occupational safety and health

dB (A) - decibel A, sound-pressure unit

kg - kilogram, weight unit

km/h - kilometre per hour, linear-speed unit

kPa - kilopascal, pressure unit

kW - kilowatt, power unit

m - metre, length unit

min - minute, an auxiliary time unit equal to 60 seconds

mm - millimetre, an auxiliary length unit equal to 0.001m

mPa - megapascal, pressure unit

N - newton – an SI unit of force

Pictogram - an information plate

T - tonne, a unit of mass

Rating plate - the manufacturer's plate unambiguously identifying the machine

V - Volt, a voltage unit

Transport hitch – the hitch components of an agricultural tractor (see tractor's Instructions Manual I).

ALPHABETICAL INDEX

B

Bearing-play adjustment	35
Bearings	35
Brake system	25
Brakes	36-39
Chassis	23
Coupling a trailer	32

D

Design description	23
Disposal	47

E

Electrical system	24
Equipment	11

F

Failures	43
----------	----

G

Guarantee	49
-----------	----

H

Hydraulic lines	41
Hydraulic mechanism	23
Hydraulic system	41

I

Identification of the trailer	9
Intended use	10

L

Lighting system	25
Load	34
Load area	23
Load space	23
Loading of the load-carrying body	29
Lubrication	44
Lubrication points	44

O

Operating principle - brakes	39
------------------------------	----

P

Pneumatic system	17
------------------	----

R

Rating plate	9
Repairs	46
Residual Risk	48

S	
Safety	13
Sales	28
Starting up	29
Storage	18
Storage	26
Suspension	21
T	
Technical Data	21
Tilt of the load-carrying body	31
Transport	12
Tyres	16
U	
Unloading the load-carrying body	29
W	
Warning signs	18

NOTES

A large rectangular area containing horizontal dotted lines for taking notes.

A series of horizontal dotted lines spanning the width of the page, providing a template for handwritten notes or a checklist.

A series of horizontal dotted lines spanning the width of the page, providing a template for handwritten text or notes.

A series of horizontal dotted lines spanning the width of the page, providing a template for handwritten notes or a checklist.



Since Metal-Fach Sp. z o.o. is continuously improving its products and adapting its commercial product range to meet the customers' needs, we reserve the right to modify our products without prior notice. Therefore, we advise contacting an authorised dealer or sales representative of Metal-Fach Sp. z o.o., prior to making your decision about purchase. Metal-Fach Sp. z o.o. will not accept any complaints regarding the data and pictures contained in the catalogue, as the presented package must not constitute an offer, within the meaning of the provisions of the Civil Code.

The pictures do not necessarily show standard accessories.

Original spare parts are available from authorised dealers, both in Poland and abroad, and also at the Metal-Fach retail outlet.

SERVICE

ul. Kresowa 6216-100 Sokółka
Tel.: +48 85 711 07 80; Fax: +48 85 711 07 93
serwis@metalfach.com.pl

SALES

ul. Kresowa 6216-100 Sokółka
Tel.: +48 85 711 07 78; Fax: +48 85 711 07 89
handel@metalfach.com.pl

SPARE PARTS WHOLESALE STORE

ul. Kresowa 6216-100 Sokółka

Wholesale:

Tel.: +48 85 711 07 80; Fax: +48 85 711 07 93
serwis@metalfach.com.pl

Retail:

Tel.: +48 85 711 07 80; Fax: +48 85 711 07 93
serwis@metalfach.com.pl

CURRENT INFORMATION ABOUT OUR PRODUCTS CAN BE FOUND ON WWW.METALFACH.COM.PL

